



MOTOR VIBRATION

MOTOR VIBRATION

Monitoring vibration on induction motors is at the core of any predictive maintenance program. Typical applications demand vibration measurements in the horizontal, vertical and axial direction on both the inboard and outboard motor bearings. Aside from typical mechanical issues, such as misaligned couplings and unbalance, the vibration analyst can also detect electrical issues that cause mechanical vibrations. Some common electrical faults include air gap variation, broken rotor bars and bearing fluting.

Vibration analysts can use one accelerometer, mounted magnetically and rotate it around the motor to capture various data collection points. In some cases the motor is in an inaccessible location and thus permanent mount sensors are used and routed to a junction box for walk up data collection. Accelerometers are permanently mounted by drilling and tapping into the motor housing or they can be adhesively affixed or welded using a mounting pad.

Electric motors driving capital machinery and ancillary equipment are critical plant processes. Unscheduled shutdowns or failures result in costly downtime, equipment damage and possible safety hazards for personnel. Although your maintenance engineers can't be everywhere at once, IMI® vibration and fault transmitters provide continuous protection and early detection of issues such as soft foot, imbalance, bearing faults, bearing fluting and misalignment. Using a 4-20 mA signal, our transmitters directly communicate with customer PLC, PI, SCADA, or DCS systems and data can be easily trended, managed, with proper alerts and notifications to keep your process up and running.

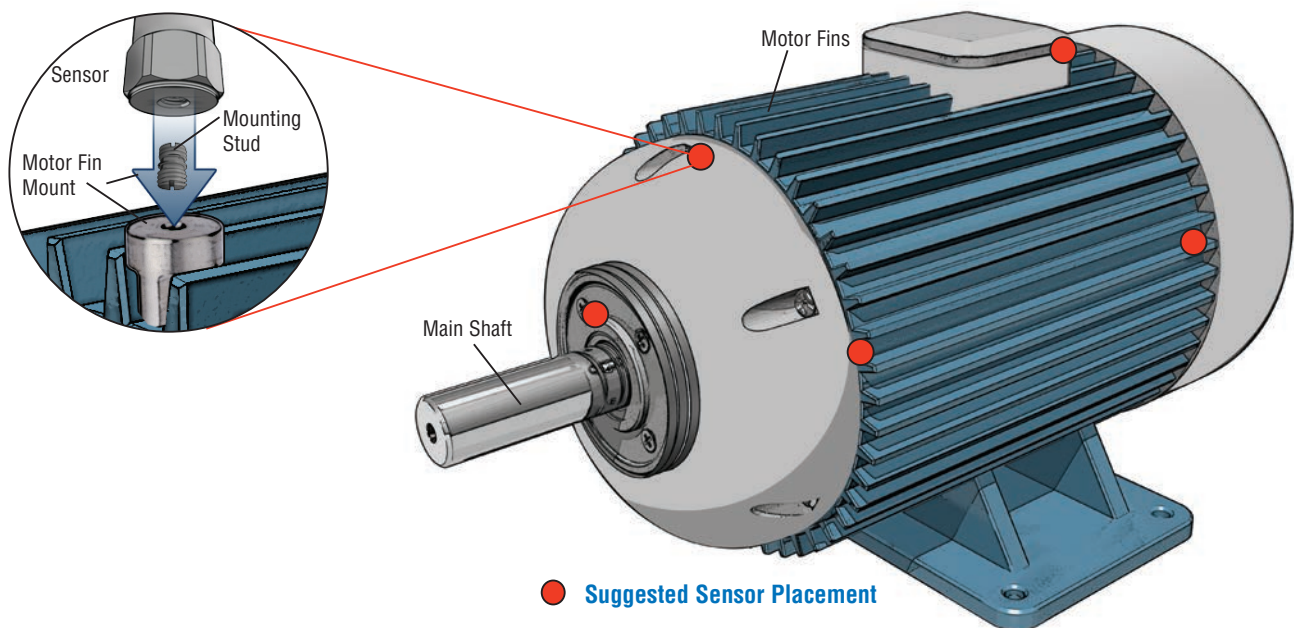

SINGE AXIS ICP® ACCELEROMETERS



CE



LOW COST SIDE EXIT ACCELEROMETER

MODEL 602D01, 602D91

- Easy installation in tight spaces
- Through-bolt aides in cable orientation
- Low profile, less than 1 in. height
- M12 connector version available



CE



LOW COST TOP EXIT ACCELEROMETER

MODEL 603C01

- General purpose, hermetically sealed
- IMI's most popular accelerometer
- Small footprint
- M12 connector version available



CE



PRECISION TOP EXIT ACCELEROMETER

MODEL 622B01

- Full frequency sweep calibration: 5% sensitivity deviation tolerance
- 15 kHz high frequency response ideal for early detection of bearing faults
- Ideal for route-based data collection

TRIAXIAL ICP® ACCELEROMETERS



CE



LOW COST ACCELEROMETER

MODEL 604B31

- General purpose, hermetically sealed accelerometer
- Perfect for permanent mount applications

CE



PRECISION ACCELEROMETER

MODEL 629A31

- Ideal for route-based data collection, magnet mount
- Full frequency sweep calibration, superior frequency response

CE



HIGH FREQUENCY ACCELEROMETER

MODEL 639A91

- Frequency Range up to 13 kHz
- M12 connector
- Intrinsically safe/explosion proof versions available

VIBRATION TRANSMITTERS



CE



VIBRATION TRANSMITTER

MODEL 682C03

- Outputs 4-20 mA signal proportional to acceleration, velocity, or displacement
- ICP® accelerometer input
- Analog vibration output via front BNC



CE



4-20 mA OUTPUT SENSOR

MODEL 640B01

- Peak velocity
- Side exit housing available
- Intrinsically safe/explosion proof versions available



CE



4-20 mA OUTPUT SENSOR, M12 CONNECTOR

MODEL 655A91

- Frequency response up to 2 kHz
- Small footprint in height and weight
- Rated to 105 °C



3425 Walden Avenue, Depew, NY 14043 USA

pcb.com/imi-sensors | imi@pcb.com | 800 959 4464 | +1 716 684 0003

© 2023 PCB Piezotronics - all rights reserved. PCB Piezotronics is a wholly-owned subsidiary of Amphenol Corporation. Endevo is an assumed name of PCB Piezotronics of North Carolina, Inc., which is a wholly-owned subsidiary of PCB Piezotronics, Inc. Accumetrics, Inc. and The Modal Shop, Inc. are wholly-owned subsidiaries of PCB Piezotronics, Inc. IMI Sensors and Larson Davis are Divisions of PCB Piezotronics, Inc. Except for any third party marks for which attribution is provided herein, the company names and product names used in this document may be the registered trademarks or unregistered trademarks of PCB Piezotronics, Inc., PCB Piezotronics of North Carolina, Inc. (d/b/a Endevo), The Modal Shop, Inc. or Accumetrics, Inc. Detailed trademark ownership information is available at www.pcb.com/trademarkownership.

IMI-APP-Motors-0923