



# Reduction in Emissions isn't just Desired. It's Required.

*4 ways to achieve NOx reductions without turbine damage*





# eBook Highlights

---

In this eBook you will learn the following:

- **Helpful questions to ask about your emission reduction strategy**
- **What is NOx emissions and how do they relate to combustion instability**
- **How to control combustion dynamics**
- **4 ways to monitor combustion instability**
- **Where to get more information**
- **How to get a free demo of turbine sensors**



# Are you prepared to reduce NOx?

---

- 
1. Government requires all industries to reduce NOx emissions. Are you prepared to incur harsh financial penalties if *you* don't?
  2. What measures have *you* implemented to reduce NOx emissions?
  3. Are you protected against potential catastrophic failures that result from NOx reduction strategies?
  4. What does your condition monitoring look like?

# What is NOx?

## And how does it relate to combustion instability?

---

The production of NOx emissions occurs in the combustion process of the gas turbine.

NOx emissions are kept low by using lower combustion temperatures and burning leaner fuel mixtures.

However, this combination can lead to combustion instability.

This instability can damage components in the combustion chamber such as nozzles, baskets and transition pieces, as well as downstream components, such as blades.

The damage invariably results in downtime, loss of production, and costly repairs. Further, a breakdown of one turbine component, such as a blade, has a domino effect on many other parts, resulting in serious repair costs.

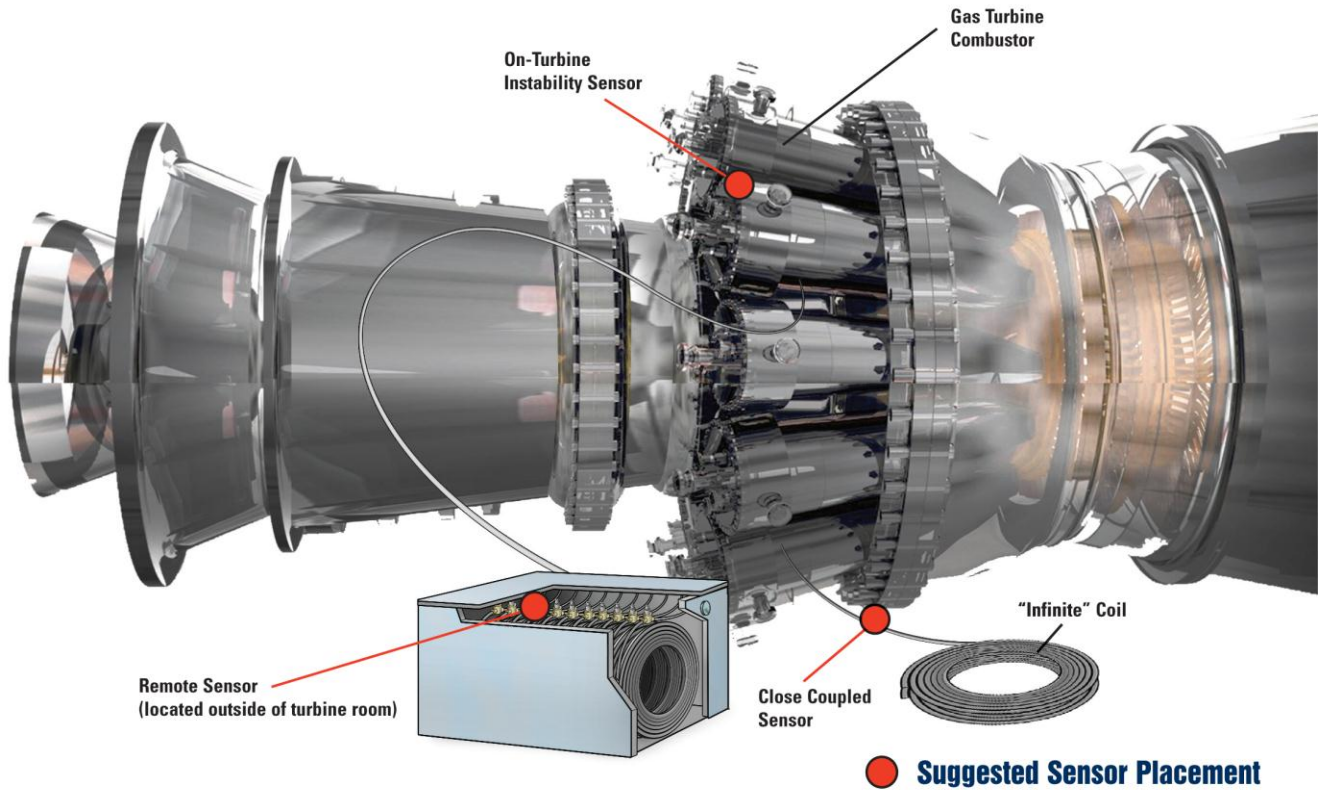

---

***Turbine operators who utilize NOx reduction strategies use sensors to measure dynamic pressure to obtain early warning of conditions that can lead to excessive pulsations and cause instability.***

---

# How to Control Combustion Dynamics

## While reducing NOx emissions

Strict emission laws and regulations make it difficult for many gas turbines to continue operation with old combustion technology producing high NOx emissions.

For decades, gas turbine operators have used pressure sensors and specialty accelerometers to monitor pressure and vibration levels within very demanding, high temperature environments.

This technology is designed to detect and measure dynamic pressure spikes, pulsations and surges in gas turbine engines.

**Turn to learn 4 ways to monitor combustion dynamics:**



# #1

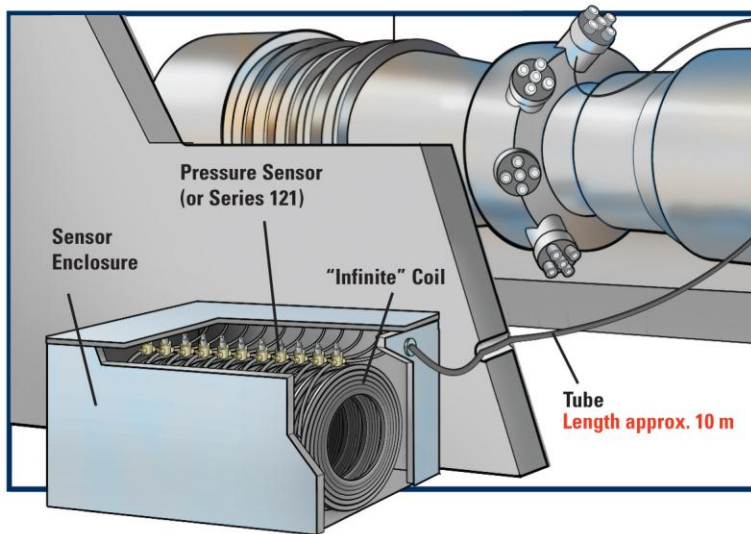

- **Remote sensors**
- Low cost
- Measures pressure
- Portable or permanent installation options available

# #2

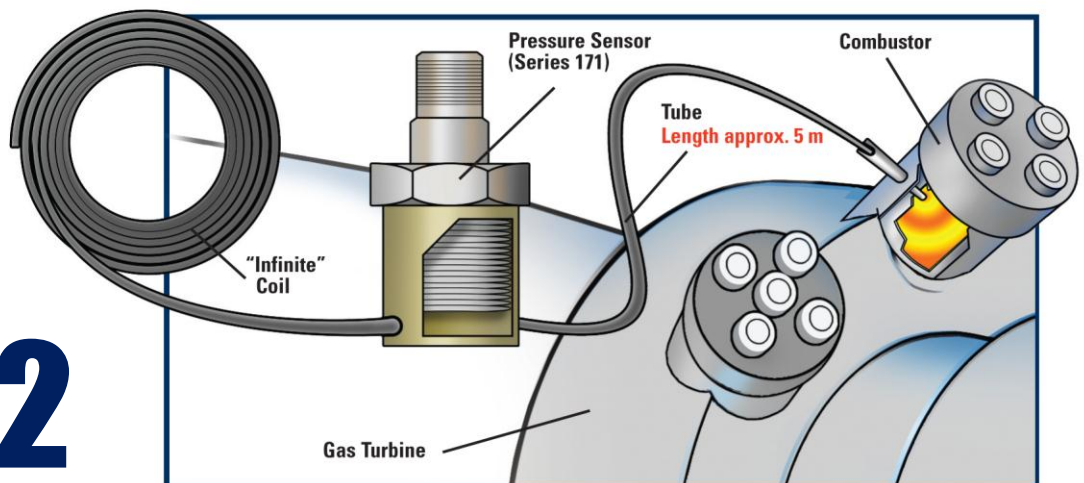

- **Close coupled sensors**
- Higher accuracy
- Precision pressure sensor
- Higher cost

# # 3

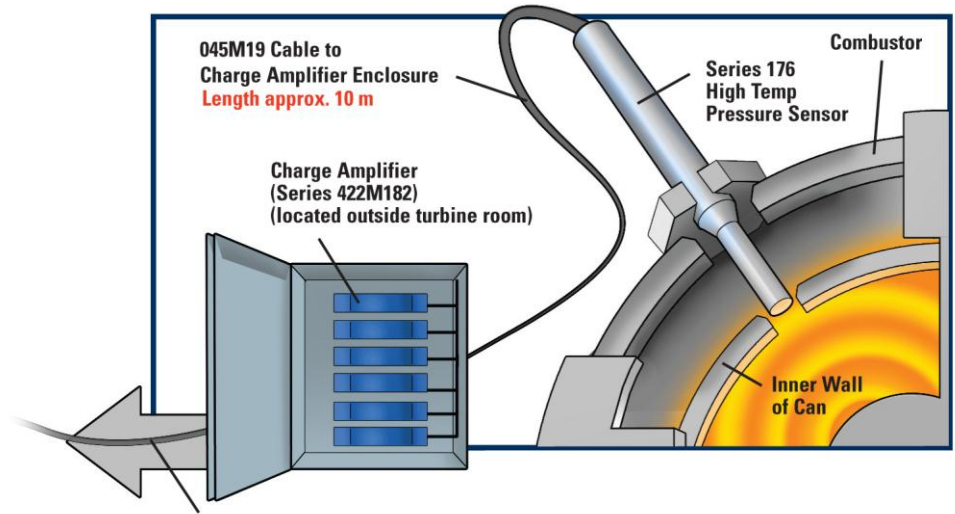

- **On-turbine instability sensors**
- Mounted directly on the combustor
- Highest cost
- Most reliable

# # 4



- **High temperature accelerometers**
- Measure vibration
- Withstand temperatures up to 1300 ° F



# What's Next?

---

Bottom line, reduction in NOx emissions is required to comply with the environmental legislation worldwide.

Since it causes combustion instability that leads to machine breakdown, it's imperative to have a condition monitoring program to ensure trouble-free operation, prevent catastrophic failures, unscheduled downtime, loss of productivity, and even worker safety.

**Visit IMI Sensors  
to Request Demo**



**IMI SENSORS**  
A PCB PIEZOTRONICS DIV.