



**Model 102A44**

**Intrinsic safe ICP® pressure sensor, 50 psi, 100 mV/psi, ground isolated, 10-32 connector, temp to 250F**

**Installation and Operating Manual**

**For assistance with the operation of this product,  
contact the PCB Piezotronics, Inc.**

**Toll-free: 716-684-0001  
24-hour SensorLine: 716-684-0001  
Fax: 716-684-0987  
E-mail: [info@pcb.com](mailto:info@pcb.com)  
Web: [www.pcb.com](http://www.pcb.com)**



## Repair and Maintenance

PCB guarantees Total Customer Satisfaction through its “Lifetime Warranty Plus” on all Platinum Stock Products sold by PCB and through its limited warranties on all other PCB Stock, Standard and Special products. Due to the sophisticated nature of our sensors and associated instrumentation, **field servicing and repair is not recommended and, if attempted, will void the factory warranty.**

Beyond routine calibration and battery replacements where applicable, our products require no user maintenance. Clean electrical connectors, housings, and mounting surfaces with solutions and techniques that will not harm the material of construction. Observe caution when using liquids near devices that are not hermetically sealed. Such devices should only be wiped with a dampened cloth—never saturated or submerged.

In the event that equipment becomes damaged or ceases to operate, our Application Engineers are here to support your troubleshooting efforts 24 hours a day, 7 days a week. Call or email with model and serial number as well as a brief description of the problem.

## Calibration

Routine calibration of sensors and associated instrumentation is necessary to maintain measurement accuracy. We recommend calibrating on an annual basis, after exposure to any extreme environmental influence, or prior to any critical test.

PCB Piezotronics is an ISO-9001 certified company whose calibration services are accredited by A2LA to ISO/IEC 17025, with full traceability to SI through N.I.S.T. In addition to our standard calibration services, we also offer specialized tests, including: sensitivity at elevated or cryogenic temperatures, phase response, extended high or low frequency response, extended range, leak testing, hydrostatic pressure testing, and others. For more information, contact your local PCB Piezotronics distributor, sales representative, or factory customer service representative.

## Returning Equipment

If factory repair is required, our representatives will provide you with a Return Material Authorization (RMA) number, which we use to reference any information you have already provided and expedite the repair process. This number should be clearly marked on the outside of all returned package(s) and on any packing list(s) accompanying the shipment.

## Contact Information

PCB Piezotronics, Inc.  
3425 Walden Ave.  
Depew, NY14043 USA  
Toll-free: (800) 828-8840  
24-hour SensorLine: (716) 684-0001  
General inquiries: [info@pcb.com](mailto:info@pcb.com)  
Repair inquiries: [rma@pcb.com](mailto:rma@pcb.com)

For a complete list of distributors, global offices and sales representatives, visit our website, [www.pcb.com](http://www.pcb.com).

## Safety Considerations

This product is intended for use by qualified personnel who recognize shock hazards and are familiar with the precautions required to avoid injury. While our equipment is designed with user safety in mind, the protection provided by the equipment may be impaired if equipment is used in a manner not specified by this manual.

Discontinue use and contact our 24-Hour Sensorline if:

- Assistance is needed to safely operate equipment
- Damage is visible or suspected
- Equipment fails or malfunctions

For complete equipment ratings, refer to the enclosed specification sheet for your product.

## Definition of Terms and Symbols

The following symbols may be used in this manual:



### DANGER

Indicates an immediate hazardous situation, which, if not avoided, may result in death or serious injury.

**CAUTION**

Refers to hazards that could damage the instrument.

**NOTE**

Indicates tips, recommendations and important information. The notes simplify processes and contain additional information on particular operating steps.

**The following symbols may be found on the equipment described in this manual:**



This symbol on the unit indicates that high voltage may be present. Use standard safety precautions to avoid personal contact with this voltage.



This symbol on the unit indicates that the user should refer to the operating instructions located in the manual.



This symbol indicates safety, earth ground.



PCB工业监视和测量设备 - 中国RoHS2公布表

PCB Industrial Monitoring and Measuring Equipment - China RoHS 2 Disclosure Table

部件名称	有害物质					
	铅 (Pb)	汞 (Hg)	镉 (Cd)	六价铬 (Cr(VI))	多溴联苯 (PBB)	多溴二苯醚 (PBDE)
住房	0	0	0	0	0	0
PCB板	X	0	0	0	0	0
电气连接器	0	0	0	0	0	0
压电晶体	X	0	0	0	0	0
环氧	0	0	0	0	0	0
铁氟龙	0	0	0	0	0	0
电子	0	0	0	0	0	0
厚膜基板	0	0	X	0	0	0
电线	0	0	0	0	0	0
电缆	X	0	0	0	0	0
塑料	0	0	0	0	0	0
焊接	X	0	0	0	0	0
铜合金/黄铜	X	0	0	0	0	0
本表格依据 SJ/T 11364 的规定编制。						
0：表示该有害物质在该部件所有均质材料中的含量均在 GB/T 26572 规定的限量要求以下。						
X：表示该有害物质至少在该部件的某一均质材料中的含量超出 GB/T 26572 规定的限量要求。						
铅是欧洲RoHS指令2011/65/ EU附件三和附件四目前由于允许的豁免。						

CHINA RoHS COMPLIANCE

Component Name	Hazardous Substances					
	Lead (Pb)	Mercury (Hg)	Cadmium (Cd)	Chromium VI Compounds (Cr(VI))	Polybrominated Biphenyls (PBB)	Polybrominated Diphenyl Ethers (PBDE)
Housing	O	O	O	O	O	O
PCB Board	X	O	O	O	O	O
Electrical Connectors	O	O	O	O	O	O
Piezoelectric Crystals	X	O	O	O	O	O
Epoxy	O	O	O	O	O	O
Teflon	O	O	O	O	O	O
Electronics	O	O	O	O	O	O
Thick Film Substrate	O	O	X	O	O	O
Wires	O	O	O	O	O	O
Cables	X	O	O	O	O	O
Plastic	O	O	O	O	O	O
Solder	X	O	O	O	O	O
Copper Alloy/Brass	X	O	O	O	O	O

This table is prepared in accordance with the provisions of SJ/T 11364.

O: Indicates that said hazardous substance contained in all of the homogeneous materials for this part is below the limit requirement of GB/T 26572.

X: Indicates that said hazardous substance contained in at least one of the homogeneous materials for this part is above the limit requirement of GB/T 26572.

Lead is present due to allowed exemption in Annex III or Annex IV of the European RoHS Directive 2011/65/EU.

**OPERATION MANUAL FOR  
ICP® PRESSURE SENSORS  
Models 102A02, A05, A07, A09  
Models 112A21, A22, A23**

**1.0 INTRODUCTION**

The series of miniature pressure sensors described by this operating guide is designed for low pressure, high resolution applications and features acceleration compensation.

Uses include monitoring of low pressure hydraulic and pneumatic phenomena in the presence of shock and vibration such as on jet engines, compressors, turbines and other operating machinery, high intensity sound and turbulence measurements, and many other industrial R & D applications.

**2.0 DESCRIPTION**

This series is comprised of six sensor models having high sensitivities, but differing in mechanical configuration.

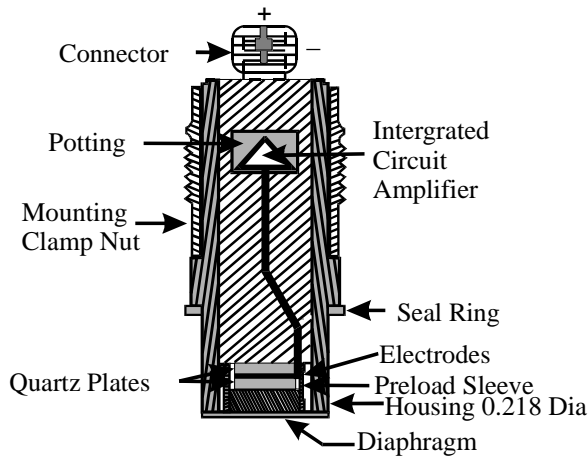

**Typical ICP® Probe Style Sensor**

Each model utilizes the basic ICP® pressure probe as shown in above figure. The pressure probe consists of the Model 112A high sensitivity acceleration-compensated quartz element and an IC source follower amplifier joined together as an inseparable assembly.

Refer to "General Guide to ICP® Instrumentation" G-0001B for a complete treatment of the ICP® concept.

Models 112A21, 112A22 and 112A23 are in the basic probe configuration as shown in Figure 1, and are installed with a hollow clamp nut with 5/16-24 external threads. The housings of these models are at electrical ground potential.

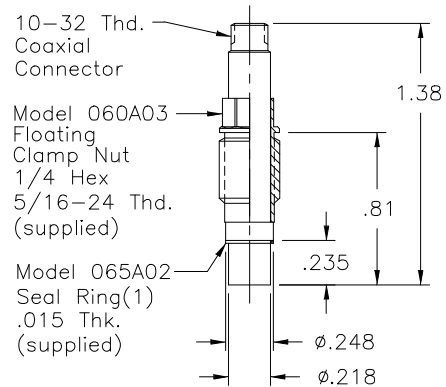

**Series 111: Probe Style Sensor**

The Model 102A05 utilizes the same basic pressure probe, mounted in a 3/8-24 threaded mounting adaptor with shoulder seal. The probe is assembled into the adaptor at the factory in an "off ground" configuration, i.e., the probe body is electrically insulated from the external mounting adaptor body. Do not attempt to disassemble probe and adaptor.

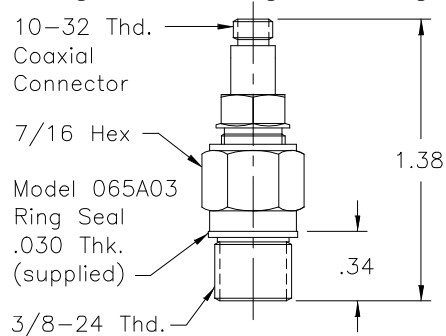

**Model 102A05 Thread Mount Design, Ground-Isolated Sensor**

**OPERATION MANUAL FOR  
ICP® PRESSURE SENSORS  
Models 102A02, A05, A07, A09  
Models 112A21, A22, A23**

Models 102A02, 102A07, and 102A09 utilize the same inner probe design but in a 3/8-24 threaded adaptor with floating clamp nut to allow adjustment of diaphragm depth where it is necessary to adapt to various wall thicknesses. These models are supplied only in low pressure (100 and 50 psi) versions and are also "off ground".

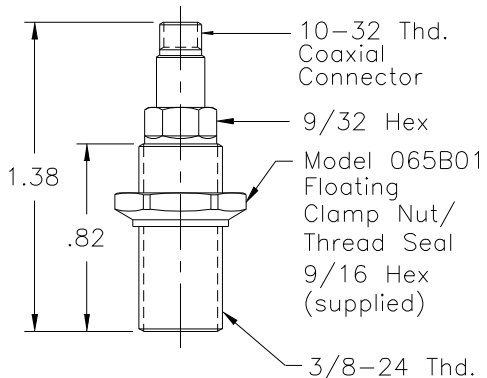

**102A's: Thread Mount with Floating Clamp Nut, Ground-Isolated Sensor**

### 3.0 INSTALLATION

This manual contains outline and installation information for your specific model in this series. Prepare mounting ports in accordance with the installation drawing for the specific model, paying particular attention to sealing surfaces. These surfaces must be smooth and free from chatter marks, nicks and other irregularities which could preclude a pressure-tight seal.

Seals are provided with each sensor and should always be used. Extra seals for all standard models are in stock at the factory. Replace seals when they become unserviceable.

In some cases, e.g., where flash temperatures such as those generated by combustion processes are present, it may be necessary to thermally insulate the diaphragm to minimize spurious signals generated by these effects.

Common black vinyl electrical tape has been found to be an effective insulating material in many cases. One or more layers may be used across the end of the diaphragm without affecting response or sensitivity.

A silicone rubber coating approximately .010" thick has also been proven effective in many applications. General Electric RTV type 106 silicone rubber is recommended. Apply the rubber coating and allow to cure in accordance with the manufacturer's instructions.

Although ICP® sensors have low output impedance and in general are not affected by moisture, in extreme environments it is good practice to protect cable connections with shrink tubing.

It is not necessary to use low-noise coaxial cable with this sensor series. In fact, a Model 070A09 solder connector adaptor that allows the use of ordinary two-wire cable is desired.

### 4.0 OPERATION

It is only necessary to supply the sensor with a 2 to 20 mA constant current at +20 to +30 VDC through a current-regulating diode or equivalent circuit. (See Guide G-0001B for powering and signal utilization information pertaining to all ICP® instrumentation).

Most of the signal conditioners manufactured by PCB have an adjustable current feature allowing a choice of input currents from 2 to 20 mA. In general, for lowest noise (best resolution) choose the low current ranges and for driving long cables (to several thousand feet) use the higher current, up to 20 mA maximum.

To operate system using a PCB signal conditioner:

1. Switch power on.
2. Wait several minutes for the IC amplifier to turn on and stabilize.
3. Proceed with measurements.

### 4.1 OPERATING CONSIDERATION FOR MODEL 112A23

The Model 112A23 features a low-noise amplifier which, based on a peak-to-peak broadband noise factor of 50  $\mu$ V, results in a resolution of .001 psi.

**OPERATION MANUAL FOR  
ICP® PRESSURE SENSORS  
Models 102A02, A05, A07, A09  
Models 112A21, A22, A23**

Defined for practical purposes as the minimum readout signal, the resolution is based on the sensitivity of 50 mV/psi and a low noise amplifier of 50  $\mu$ V peak noise.

Thus,  $50 \mu\text{V}/50\text{mV} = .001$  psi resolution

The output bias voltage of the Model 112A23 is 5.0 volts, half the bias voltage of most PCB pressure sensors. This will cause the bias monitor meter on PCB power supplies to read at the low end of the green band.

## 5.0 POLARITY

This sensor series produces a positive-going output voltage for increasing pressure input.

## 6.0 LOW FREQUENCY RESPONSE

The low frequency response of an ICP® system is determined by:

1. The discharge time constant of the sensor, and,
2. If AC-coupled at power unit, the coupling time constant.

Consult Section 7.0 in Guide G-0001B for detailed explanation of low frequency characteristics of ICP® instruments.

## 7.0 CALIBRATION

Piezoelectric sensors are dynamic devices, but static calibration methods may be employed if discharge time constants are sufficiently long. Generally, static methods are not employed below several hundred seconds discharge time constant.

To employ static methods, directly couple the sensor to the DVM readout using a T-connector from the XD4R jack or use the Model 484B in the "calibrate" mode. Apply pressure with dead weight tester and take readings quickly. Release pressure after each calibration point.

For the shorter discharge time constant series, a rapid pressure step must be generated by a pneumatic pressure pulse calibrator or dead weight tester and readout is by recorder or storage oscilloscope.

PCB offers a complete recalibration service. Consult factory for details.



**OPERATION MANUAL FOR  
ICP® PRESSURE SENSORS  
Models 102A02, A05, A07, A09  
Models 112A21, A22, A23**

## **8.0 MAINTENANCE**

The miniature size sealed construction precludes field maintenance. Should service be required, return unit to factory with note describing problem.

®ICP is a registered trademark of PCB Piezotronics

APPLICATION		
NEXT ASS'Y	USED ON	VAR

PCB Piezotronics Inc. claims proprietary rights in the information disclosed hereon. Neither it nor any reproduction thereof will be disclosed to others without written consent of PCB Piezotronics Inc.

REVISIONS					
ZONE	REV	DESCRIPTION	ECN	DATE	APP'D
	A	REVISED PER ECR	22357	6/14/05	DM6/05
	B	UPDATE DRAWING	25017	9/19/06	MEM/06

Schedule Drawing  
No modifications permitted without reference to the Notified Body

- 4 SHIELDS TO BE EARTHED AT BARRIER ENDS.
- 3 THE INSTALLER SHALL INSURE THAT THE TRANSDUCER MOUNTING STRUCTURE IS AT THE SAME GROUNDING POTENTIAL AS THE BARRIER GROUND. TOTAL EARTH LOOP IMPEDANCE SHALL BE LESS THAN 1 OHM.
- 2 BARRIER WILL BE MOUNTED IN AN ENCLOSURE THE SUITABILITY OF WHICH WILL BE DETERMINED BY LOCAL AUTHORITIES.
- 1 ENTITY APPLICATION

BARRIER	I.S. APPARATUS
$V_{oc}/U_o \leq$	$V_{max} / U_I$
$I_{sc}/I_o \leq$	$I_{max} / I_I$
$C_a/C_o >$	$C_I + C_{CABLE}$
$L_a/L_o >$	$L_I + L_{CABLE}$
$P_o \leq$	$P_I$ (CENELEC ONLY)

BARRIERS WITHIN THE SPECIFIED LIMITATIONS ARE PERMITTED

ENTITY PARAMETERS

- $U_i = 30V$
- $I_i = 200\text{ mA}$
- $P_i = 1\text{ W}$
- $C_i = 5.0\text{ nF}$
- $L_i = 0\text{ }\mu\text{H}$

CERTIFIED BY THE APPROPRIATE APPROVAL AUTHORITY FOR CONNECTION TO THE FOLLOWING AREAS:

- ZONE 0
  - Exia IIC
  - AExia IIC
- DIV 1
  - CLASS I, GROUPS A,B,C,D
- ZONE 0
  - Exia IIC

$V_{IN} \leq +28\text{ VOLTS}$

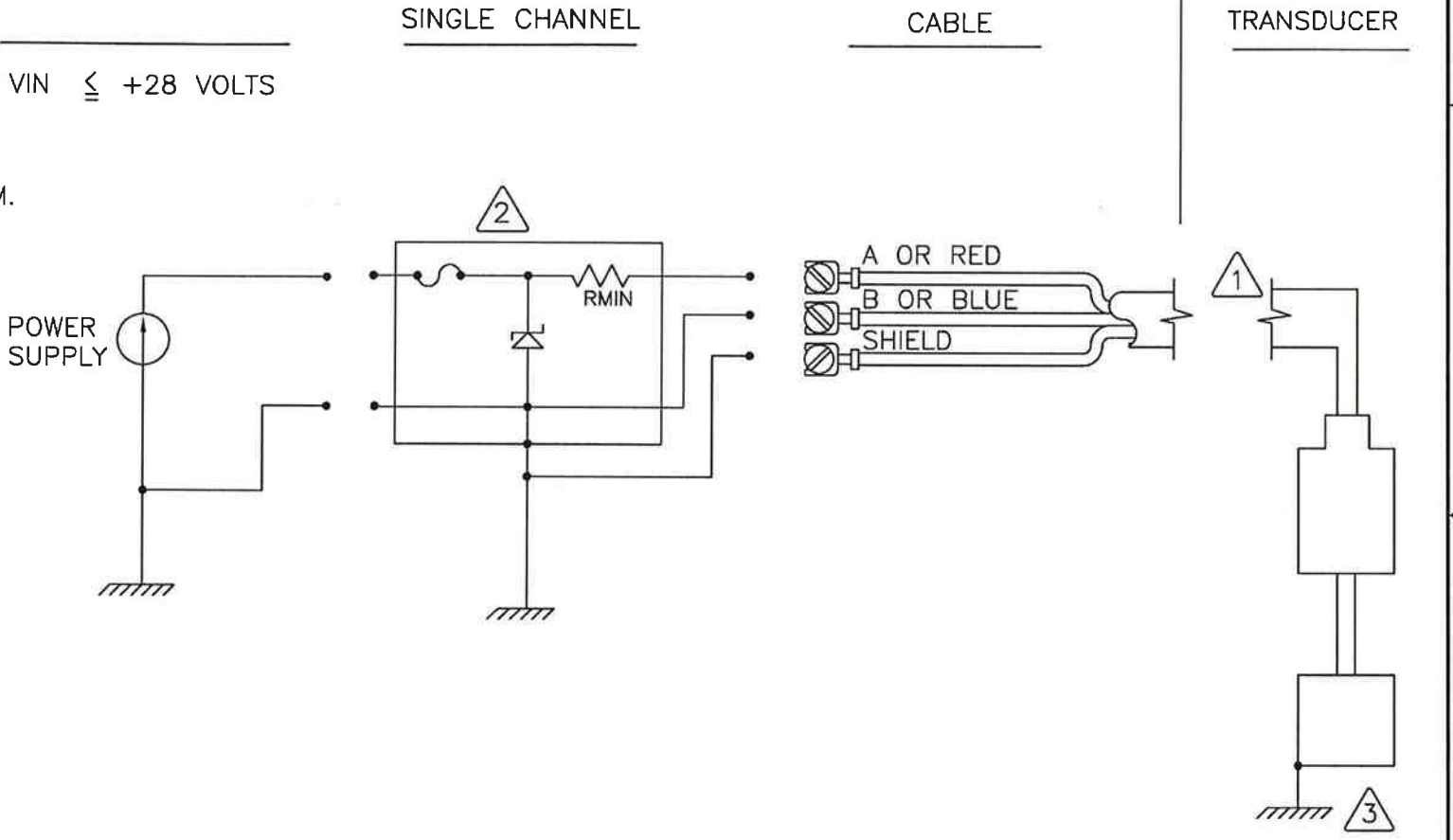

NO CHANGES WITHOUT CSA/LCIE APPROVAL

UNLESS OTHERWISE SPECIFIED  
DIMENSIONS ARE IN INCHES  
DECIMALS X ± .05  
XX ± .01  
XXX ± .005  
ANGLES ±2 DEGREES  
FILLETS AND RADII .003 - .005  
HEX DIMENSIONS ARE:  
< 0.5 +.000 / -.003  
> 0.5 +.000 / -.005  
INTERNAL THREAD DEPTH MIN  
REMOVE ALL BURRS  
SHARP = R.000 - R.003  
DD016 REV. D 01/17/2003



DRAWN	ECB	11/6/06	MFG	RC	11-30-06
CHK'D	DM	11/6/06	ENGR	RF	9-22-06
APP'D	MEM	12/1/06			

CSA/LCIE APPROVAL  
INTERCONNECTION

**PCB PIEZOTRONICS**  
3425 WALDEN AVE. DEPEW, NY 14043  
(716) 684-0001 EMAIL: SALES@PCB.COM

CODE IDENT. NO.	DWG. NO.
52681	21869
SCALE: FULL SHEET 1 OF 2	

APPLICATION		
NEXT ASS'Y	USED ON	VAR

PCB Piezotronics Inc. claims proprietary rights in the information disclosed hereon. Neither it nor any reproduction thereof will be disclosed to others without written consent of PCB Piezotronics Inc.

REVISIONS				
ZONE	REV	DESCRIPTION	ECN	DATE
		- SEE SHEET ONE -		
				APP'D <i>Dir 11/06</i>

Schedule Drawing  
No modifications permitted without reference to the Notified Body

21869

APPROVED  
POWER SUPPLY/  
SIGNAL CONDITIONER

NON-HAZARDOUS / SAFE AREA  
OR DIV 2 / ZONE 2

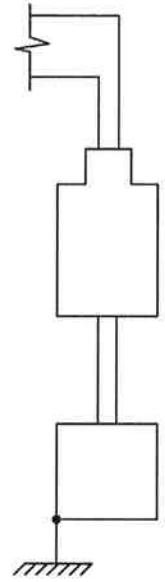
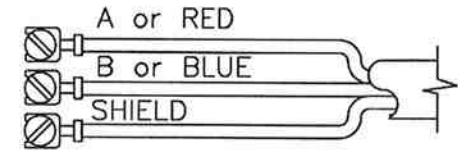
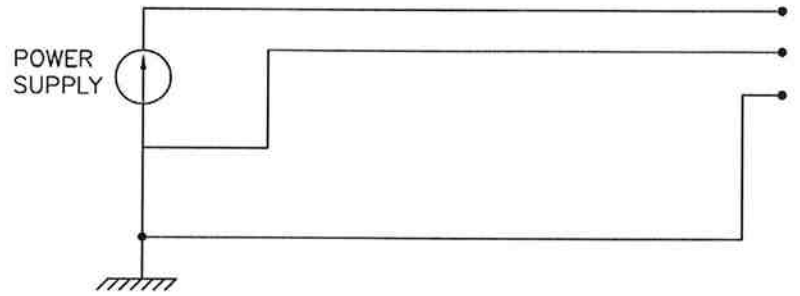

4. FOR CANADIAN, DIVISION 2 AND ZONE 2 INSTALLATION, POWER SUPPLY MUST BE CSA CERTIFIED WITH ENTITY OUTPUT PARAMETERS FOR U.S DIVISION 2 AND ZONE 2 INSTALLATION, POWER SUPPLY MUST BE APPROVED BY NRTL WITH ENTITY OUTPUT PARAMETERS.

ENTITY APPLICATION

<u>BARRIER</u>		<u>I.S. APPARATUS</u>
Voc/Uo	≤	V <sub>MAX</sub> / UI
Isc/Io	≤	I <sub>MAX</sub> / II
Ca/Co	>	CI + C <sub>CABLE</sub>
La/Lo	>	LI + L <sub>CABLE</sub>
Po	≤	PI (CENELEC ONLY)

ENTITY PARAMETERS:

- Ui = 30 V
- Ii = 200 mA
- Pi = 1 W
- Ci = 5.0 nF
- Li = 0 μH

- 3. MAXIMUM VOLTAGE OF POWER SUPPLY/SIGNAL CONDITIONER NEVER TO EXCEED 250 Vrms. NO CHANGES WITHOUT CSA/LCIE APPROVAL
- 2. FOR GUIDANCE ON CANADIAN INSTALLATION, REFER TO CEC PART I. FOR GUIDANCE ON U.S. INSTALLATION, INSTALL IN ACCORDANCE WITH NEC [ANSI/NFPA70] AND [ANSI/ISA RP12.6].
- 1. CERTIFIED BY THE APPROPRIATE APPROVAL AUTHORITY FOR CONNECTION TO THE FOLLOWING AREAS:

- ZONE 2  
ExnL IIC, AExnA IIC T4
- DIV 2  
CLASS I, GROUPS A, B, C, D
- ZONE 2  
ExnL IIC  
ExnA IIC

UNLESS OTHERWISE SPECIFIED  
DIMENSIONS ARE IN INCHES  
DECIMALS X ± .05  
XX ± .01  
XXX ± .005  
ANGLES ±2 DEGREES  
FILLETS AND RADII .003 - .005  
HEX DIMENSIONS ARE:  
< 0.5 +.000 / -.003  
> 0.5 +.000 / -.005  
INTERNAL THREAD DEPTH MIN  
REMOVE ALL BURRS  
SHARP = R.000 - R.003  
DD016 REV. D 01/17/2003



DRAWN	ECB	11/6/06	MFG	RC	11-30-06
CHK'D	DM	11/6/06	ENGR	RF	9-22-04
APP'D	MEM	12/1/06			

CSA/LCIE APPROVAL  
INTERCONNECTION

**PCB PIEZOTRONICS™**  
3425 WALDEN AVE. DEPEW, NY 14043  
(716) 684-0001 EMAIL: SALES@PCB.COM

CODE IDENT. NO. 52681	DWG. NO. 21869
SCALE: FULL SHEET 2 OF 2	

	ENGLISH	SI
<b>Performance</b>		
Measurement Range(for ±5V output)	50 psi	344.8 kPa
Sensitivity(± 15 %)	100 mV/psi	14.503 mV/kPa
Maximum Pressure	4 kpsi	27,580 kPa [1]
Resolution	0.1 mpsi	0.00069 kPa [2]
Resonant Frequency	≥ 250 kHz	≥ 250 kHz
Rise Time(Reflected)	≤ 2 μ sec	≤ 2 μ sec
Low Frequency Response(- 5 %)	0.5 Hz	0.5 Hz
Non-Linearity	≤ 1.0 % FS	≤ 1.0 % FS [3]
<b>Environmental</b>		
Acceleration Sensitivity	0.002 psi/g	0.0014 kPa/(m/s <sup>2</sup> ) [2]
Temperature Range(Operating)	-65 to +250 °F	-54 to +121 °C
Temperature Coefficient of Sensitivity	≤ 0.03 %/°F	≤ 0.054 %/°C
Maximum Flash Temperature	3,000 °F	1,649 °C
Maximum Vibration	2,000 g pk	19,600 m/s <sup>2</sup> pk
Maximum Shock	20,000 g pk	196,000 m/s <sup>2</sup> pk
Hazardous Area Approval	See Manual	See Manual
<b>Electrical</b>		
Output Polarity(Positive Pressure)	Positive	Positive
Discharge Time Constant(at room temp)	≥ 1.0 sec	≥ 1.0 sec
Excitation Voltage	20 to 28 VDC	20 to 28 VDC
Constant Current Excitation	2 to 20 mA	2 to 20 mA
Output Impedance	< 100 Ohm	< 100 Ohm
Output Bias Voltage	8 to 14 VDC	8 to 14 VDC
Electrical Isolation	10 <sup>8</sup> Ohm	10 <sup>8</sup> Ohm
<b>Physical</b>		
Sensing Geometry	Compression	Compression
Sensing Element	Quartz	Quartz
Housing Material	Stainless Steel	Stainless Steel
Diaphragm	316L Stainless Steel	316L Stainless Steel [4]
Sealing	Welded Hermetic	Welded Hermetic
Electrical Connector	10-32 Coaxial Jack	10-32 Coaxial Jack
Weight	0.6 oz	17.0 gm

**OPTIONAL VERSIONS**

Optional versions have identical specifications and accessories as listed for the standard model except where noted below. More than one option may be used.

**NOTES:**

[1]Due to high sensitivity, the static pressure should be applied and removed very slowly. Rate should prevent more than 10 Volt change in output until Output Bias Voltage returns to normal (approximately 15 times discharge time constant).

[2]Typical.

[3]Zero-based, least-squares, straight line method.

[4]Diaphragm with ablative coating.

[5]See PCB Declaration of Conformance PS059 for details.

**SUPPLIED ACCESSORIES:**

Model PCS-1AZ Sensitivity calibration at 100% and 10% of sensor range

Entered: ND	Engineer: AJA	Sales: RWM	Approved: RPF	Spec Number:
Date: 07/15/2024	Date: 07/15/2024	Date: 07/15/2024	Date: 07/15/2024	38071

**Phone: 716-684-0001**  
**Fax: 716-684-0987**  
**E-Mail: info@pcb.com**

AN AMPHENOL COMPANY

3425 Walden Avenue, Depew, NY 14043



All specifications are at room temperature unless otherwise specified.  
 In the interest of constant product improvement, we reserve the right to change specifications without notice.  
 ICP® is a registered trademark of PCB Piezotronics, Inc.

PCB Piezotronics Inc. claims proprietary rights in the information disclosed hereon. Neither it nor any reproduction thereof will be disclosed to others without the written consent of PCB Piezotronics Inc.

REVISIONS

REV	DESCRIPTION	ECN	APP'D
NR	RELEASED TO DRAFTING		

38072

Related Drawing

No modifications permitted without the approval of the authorized person

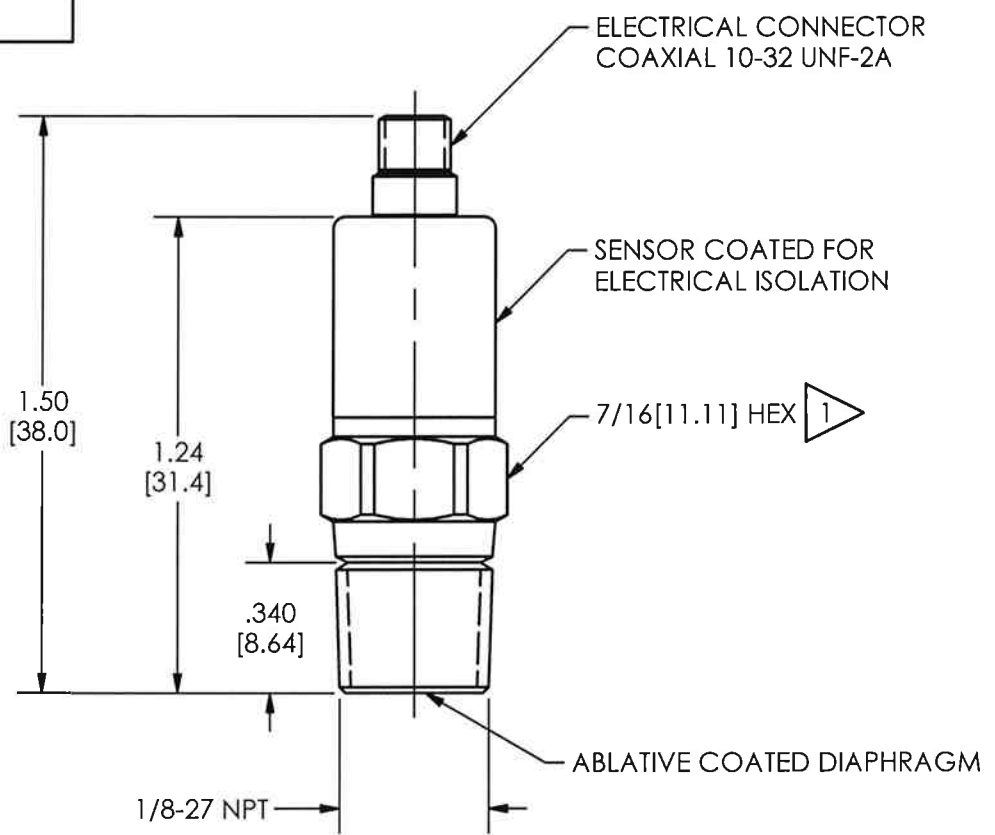

MOUNTING HOLE PREPERATION  
Ø.332[8.43]  
THRU  
1/8-27 NPT

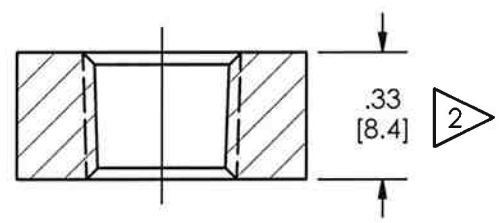

- 2 ABOVE INSTALLATION IS FOR WALL THICKNESS OF .33[8.4]. L<sub>1</sub>Ø.750[19.05] FOR THICKER WALLS TO CLEAR 7/16[11.11] SOCKET.
- 1 RECOMMENDED MOUNTING TORQUE ON A 7/16[11.11] HEX: 5 FOOT POUNDS[7 NEWTON METERS]

UNLESS OTHERWISE SPECIFIED TOLERANCES ARE:		DRAWN	FCB	7/25/07	MFG	P.R.R	7-25-07	<p>3425 WALDEN AVE. DEPEW, NY 14043 (716) 684-0001 E-MAIL: sales@pcb.com</p>
DIMENSIONS IN INCHES	DIMENSIONS IN MILLIMETERS [IN BRACKETS]	CHK'D	ECB	7/25/07	ENGR	RF	7-25-07	
DECIMALS XX ± .01 XXX ± .005	DECIMALS X ± 0.3 XX ± 0.13	APP'D	NJL	7/25/07	SALES	RLM	7-25-07	
ANGLES ± 2 DEGREES	ANGLES ± 2 DEGREES	TITLE						
FILLETS AND RADII .003 - .005	FILLETS AND RADII [0.07 - 0.13]	INSTALLATION DRAWING MODELS 102A43,44,45 PRESSURE SENSOR						CODE IDENT. NO. 52681
								DWG. NO. 38072
								SCALE: 2X
								SHEET 1 OF 1

### INSTRUCTIONS FOR USE – 1xxAyyy, 1xxByyy, and 1xxMyyy Series

Model(s)	1xxAyyy, 1xxByyy, and 1xxMyyy Series
Markings	<p>PCB Depew, NY LCIE 03 ATEX 6279X LCIE 06 ATEX 6103X IECEX LCIE 13.0065X IECEX LCIE 13.0066X Ex ia IIC T4 Ga Ex nA IIC T4 Gc <math>-54^{\circ}\text{C} \leq T_a \leq +121^{\circ}\text{C}</math></p>
Putting Into Service	<p>Powering: All ICP<sup>®</sup> sensors require constant current excitation for proper operation. For this reason, use only PCB constant-current signal conditioners or other approved constant-current sources. The power supply consists of a current-regulated, 18 to 30 VDC source. This power is regulated by a current-limiting circuit, which provides the constant-current excitation required for proper operation of ICP<sup>®</sup> sensors.</p> <p>In general, battery-powered devices offer versatility for portable, low-noise measurements, whereas line-powered units provide the capability for continuous monitoring. Consult the Pressure Division’s product catalog for more information about signal conditioners.</p> <p><b>NOTE:</b> <i>Under no circumstances should a voltage be supplied to an ICP<sup>®</sup> sensor without a current-regulating diode or equivalent electrical circuit. This may include ohmmeters, multi-meters and continuity testers.</i></p>
Safe Use	<p>After completing the system setup, switch on the signal conditioner and allow 1 to 2 minutes for the system to stabilize. The meter (or LED) on the signal conditioner should be reading “green.” This indicates proper operation and you may begin taking measurements. If a faulty condition is indicated (red or yellow reading), first check all system connections, then check the functionality of the cable and signal conditioner. If the system still does not operate properly, consult a PCB factory representative.</p> <p><b>NOTE:</b> <i>Always operate the sensor within the limitations listed on the enclosed <b>Specification Sheet</b>. Operating the device outside these parameters can cause temporary or permanent damage to the sensor.</i></p>
Assembling	<p>The 1xxAyyy, 1xxByyy, and 1xxMyyy series have a hermetically sealed housing and do not require any assembly. Only mount to the machine using standard accessories.</p>
Dismantling	<p>Other than removal from the mounting, there is no disassembly of the sensor required to take it out of service.</p>
Maintenance	<p>Routine maintenance, such as the cleaning of electrical connectors, housings, and mounting surfaces with solutions and techniques that will not harm the physical material of construction, is acceptable.</p>

Servicing	Due to the sophisticated nature of the sensors and associated instrumentation provided by PCB Piezotronics, user servicing or repair is not recommended and, if attempted, may void the factory warranty. However, routine calibration of sensors and associated instrumentation is recommended as this helps build confidence in measurement accuracy and acquired data.
Repair	In the event that equipment becomes damaged or ceases to operate, arrangements should be made to return the equipment to PCB Piezotronics for repair. User servicing or repair is not recommended and, if attempted, may void the factory warranty.
Installation	Overview: Sensor must be mounted in order to be put into service. When choosing a mounting method, consider closely both the advantages and disadvantages of each technique. Characteristics like location, ruggedness, amplitude range, accessibility, temperature, and portability are extremely critical. However, the most important and often overlooked consideration is the effect the mounting technique has on the high-frequency performance of the sensor. Mounting methods include: Recess mount or flush mount. Cabling: Care and attention to cable installation and cable condition is essential as the reliability and accuracy of any measurement system is no better than that of its weakest link. Good installation practice will extend the life of a cable, however, it is highly recommended to keep spare cables on hand to enable continuation of the test in the event of a cable failure.
Adjustment	The sensor is a sealed device and no user adjustments are possible. However, routine calibration of sensors by the manufacturer is recommended as this helps build confidence in measurement accuracy and acquired data.
Danger Areas (for pressure-relief devices)	N/A – not a pressure relief device.
Training Instructions	Industrial sensors must be installed in Hazardous Locations by trained professionals according to EN/IEC 60079-14 requirements.
Details on Safety of Protection Category	Ex ia is “intrinsic safety”, which limits the energy of sparks and surface temperatures to safe levels. Ex nA is “Non-Sparking”, which ensures that there is no risk of arcing and sparking or hot surfaces during normal operation.
Entity Parameters and Limits (Values)	Temperature Range: -54°C to +121°C. U <sub>i</sub> = 30V, I <sub>i</sub> = 200 mA, P <sub>i</sub> = 1W, C <sub>i</sub> = 5nF, L <sub>i</sub> = 0μH
Special Conditions of Use	Version Ex ia : The apparatus must only be connected to a certified associated intrinsically safe equipment. This combination must be compatible regarding intrinsic safety rules (see electrical parameters). Version Ex nA: The apparatus must only be connected to equipment whose electrical parameters are compatible with the electrical parameters.
Essential Characteristics of tools fitted to the system (if any).	N/A – No tools are fitted to the system.
Drawings and Diagrams	21869, 56617, 56620
Other	For ATEX protection “ia” – EN 60079-0 + A11:2013 and EN 60079-11:2012 For ATEX protection “nA” – EN 60079-0 + A11:2013 and EN 60079-15:2010 For IECEx protection “ia” – IEC 60079-0 Ed. 6 and IEC 60079-11 Ed. 6 For IECEx protection “nA” – IEC 60079-0 Ed. 6 and IEC 60079-15 Ed. 4

Note: Literature (such as the manual or marketing materials) describing the equipment or protective system must not contradict the instructions with regard to safety aspects.

  <b>3425 Walden Ave</b> <b>Depew, New York 14043</b>	N° 31663 Rev. D ECO #: 49079 1/23/19	N° 2 of 2
---	---	-----------



# IECEx Certificate of Conformity

## INTERNATIONAL ELECTROTECHNICAL COMMISSION IEC Certification Scheme for Explosive Atmospheres

for rules and details of the IECEx Scheme visit [www.iecex.com](http://www.iecex.com)

Certificate No.: IECEx LCIE 13.0066X issue No.:1  
Status: **Current**  
Date of Issue: **2015-11-09** Page 1 of 4

Certificate history:  
Issue No. 1 (2015-11-9)  
Issue No. 0 (2013-11-29)

Applicant: **PCB Piezotronics**  
3425 Walden Avenue,  
Depew, New York 14043  
**United States of America**

Electrical Apparatus: **Pressure Sensor**  
Optional accessory: Type : 1xxAyyy, 1xxByyy 1xxMyyy

Type of Protection: **Ex nA**

Marking: PCB Piezotronics  
Address : ...  
Type : 1xxAyyy, 1xxByyy or 1xxMyyy  
Serial number : ...  
Year of construction : ...  
Ex nA IIC T4 Gc  
IECEx LCIE 13.0066 X  
Ambient temperature : - 54°C to +121°C  
WARNING – DO NOT SEPARATE WHEN ENERGIZED.

Approved for issue on behalf of the IECEx  
Certification Body:

Julien GAUTHIER

Position:

Certification Officer

Signature:  
(for printed version)

Date:

2015-11-09

1. This certificate and schedule may only be reproduced in full.
2. This certificate is not transferable and remains the property of the issuing body.
3. The Status and authenticity of this certificate may be verified by visiting the [Official IECEx Website](http://www.iecex.com).

Certificate issued by:

**Laboratoire Central des Industries Electriques (LCIE)**  
33 Avenue du General Leclerc  
FR-92260 Fontenay-aux-Roses  
France

Documents relative to LCIE certification activities (Certificates, QARs, ExTRs) can be registered under the references "LCI" or "LCIE".



**LCIE**





# IECEx Certificate of Conformity

Certificate No.: IECEx LCIE 13.0066X

Date of Issue: 2015-11-09

Issue No.: 1

Page 2 of 4

Manufacturer: **PCB Piezotronics**  
3425 Walden Avenue,  
Depew, New York 14043  
**United States of America**

Additional Manufacturing location  
(s):

**PCB Piezotronics of  
North Carolina Inc**  
10869 Hwy 903  
Halifax, NC 27839  
United States of America

This certificate is issued as verification that a sample(s), representative of production, was assessed and tested and found to comply with the IEC Standard list below and that the manufacturer's quality system, relating to the Ex products covered by this certificate, was assessed and found to comply with the IECEx Quality system requirements. This certificate is granted subject to the conditions as set out in IECEx Scheme Rules, IECEx 02 and Operational Documents as amended.

#### STANDARDS:

The electrical apparatus and any acceptable variations to it specified in the schedule of this certificate and the identified documents, was found to comply with the following standards:

**IEC 60079-0 : 2011** Explosive atmospheres - Part 0: General requirements  
Edition: 6.0

**IEC 60079-15 : 2010** Explosive atmospheres - Part 15: Equipment protection by type of protection "n"  
Edition: 4

*This Certificate **does not** indicate compliance with electrical safety and performance requirements other than those expressly included in the Standards listed above.*

#### TEST & ASSESSMENT REPORTS:

*A sample(s) of the equipment listed has successfully met the examination and test requirements as recorded in*

#### Test Report:

FR/LCIE/ExTR13.0061/00

FR/LCIE/ExTR15.0111/00

#### Quality Assessment Report:

NL/DEK/QAR14.0004/01



# IECEx Certificate of Conformity

Certificate No.: IECEx LCIE 13.0066X

Date of Issue: 2015-11-09

Issue No.: 1

Page 3 of 4

## Schedule

### EQUIPMENT:

*Equipment and systems covered by this certificate are as follows:*

The pressure sensors 1xxAyyy, 1xxByyy, 1xxMyyy are comprised of a piezo-crystal assembly, a charge amplifier and a connector. The assembly is mounted inside a metallic enclosure.

All models use one metal enclosure to house both the piezo-crystal and the charge amplifier. The models differ from each other only in minor amplifier circuitry component values and in minor mechanical mounting variations.

The "xx" in the model number denotes frequency response.

The "yyy" in the model number denotes minor mechanical mounting variations, variations in pressure range and variations in low frequency response.

### CONDITIONS OF CERTIFICATION: YES as shown below:

Ambient temperature : - 54°C to +121°C

The supply electrical parameters shall not exceed ( $U \leq 30$  V,  $I \leq 200$  mA,  $P \leq 1$  W,  $C \leq 5$  nF,  $L \approx 0$ ).

Concerning the use of the Pressure Sensor, see instruction manual of the manufacturer.



# IECEx Certificate of Conformity

Certificate No.: IECEx LCIE 13.0066X

Date of Issue: 2015-11-09

Issue No.: 1

Page 4 of 4

## DETAILS OF CERTIFICATE CHANGES (for issues 1 and above):

**Issue 01** : Modification of QAR

This area is currently blank, indicating no further details are provided for the modification of QAR.



# IECEX Certificate of Conformity

## INTERNATIONAL ELECTROTECHNICAL COMMISSION IEC Certification Scheme for Explosive Atmospheres

for rules and details of the IECEx Scheme visit [www.iecex.com](http://www.iecex.com)

Certificate No.: IECEx LCIE 13.0066X

Issue No: 0

Certificate history:

Status: **Current**

Issue No. 1 (2015-11-09)

Issue No. 0 (2013-11-29)

Date of Issue: **2013-11-29**

Page 1 of 4

Applicant: **PCB Piezotronics Inc**  
3425 Walden Avenue,  
Depew, New York 14043  
**United States of America**

Equipment: **Pressure Sensor**

*Optional accessory:*

Type of Protection: **Non-sparking "nA"**

Marking:

PCB

Address : ...

Type : 1xxAyyy, 1xxByyy or 1xxMyyy

Serial number : ...

Year of construction : ...

Ex nA IIC T4 Gc

IECEX LCIE 13.0066 X

Ambient temperature : - 54°C to +121°C

WARNING – DO NOT SEPARATE WHEN ENERGIZED.

*Approved for issue on behalf of the IECEx  
Certification Body:*

Julien GAUTHIER

*Position:*

Certification Officer

*Signature:  
(for printed version)*

*Date:*

\_\_\_\_\_  
\_\_\_\_\_

1. This certificate and schedule may only be reproduced in full.
2. This certificate is not transferable and remains the property of the issuing body.
3. The Status and authenticity of this certificate may be verified by visiting the [Official IECEx Website](http://www.iecex.com).

Certificate issued by:



# IECEX Certificate of Conformity

Certificate No: IECEX LCIE 13.0066X

Issue No: 0

Date of Issue: 2013-11-29

Page 2 of 4

**Laboratoire Central des Industries Electriques (LCIE)**  
33 Avenue du General Leclerc  
FR-92260 Fontenay-aux-Roses  
France





# IECEX Certificate of Conformity

Certificate No: IECEX LCIE 13.0066X

Issue No: 0

Date of Issue: **2013-11-29**

Page 3 of 4

Manufacturer: **PCB Piezotronics Inc**  
3425 Walden Avenue,  
Depew, New York 14043  
**United States of America**

Additional Manufacturing location(s):

**PCB Piezotronics of North Carolina Inc**  
10869 Hwy 903  
Halifax, NC 27839  
United States of America

This certificate is issued as verification that a sample(s), representative of production, was assessed and tested and found to comply with the IEC Standard list below and that the manufacturer's quality system, relating to the Ex products covered by this certificate, was assessed and found to comply with the IECEX Quality system requirements. This certificate is granted subject to the conditions as set out in IECEX Scheme Rules, IECEX 02 and Operational Documents as amended.

#### STANDARDS:

The electrical apparatus and any acceptable variations to it specified in the schedule of this certificate and the identified documents, was found to comply with the following standards:

**IEC 60079-0 : 2011** Explosive atmospheres - Part 0: General requirements  
Edition:6.0

**IEC 60079-15 : 2010** Explosive atmospheres - Part 15: Equipment protection by type of protection "n"  
Edition:4

*This Certificate **does not** indicate compliance with electrical safety and performance requirements other than those expressly included in the Standards listed above.*

#### TEST & ASSESSMENT REPORTS:

*A sample(s) of the equipment listed has successfully met the examination and test requirements as recorded in*

Test Report:

FR/LCIE/ExTR13.0061/00

Quality Assessment Report:

CA/CSA/QAR09.0018/02



# IECEX Certificate of Conformity

Certificate No: IECEx LCIE 13.0066X

Issue No: 0

Date of Issue: 2013-11-29

Page 4 of 4

## Schedule

### EQUIPMENT:

*Equipment and systems covered by this certificate are as follows:*

The pressure sensors 1xxAyyy, 1xxByyy, 1xxMyyy are comprised of a piezo-crystal assembly, a charge amplifier and a connector .  
The assembly is mounted inside a metallic enclosure.

All models use one metal enclosure to house both the piezo-crystal and the charge amplifier. The models differ from each other only in minor amplifier circuitry component values and in minor mechanical mounting variations.

The "xx" in the model number denotes frequency response.

The "yyy" in the model number denotes minor mechanical mounting variations, variations in pressure range and variations in low frequency response.

### SPECIFIC CONDITIONS OF USE: YES as shown below:

Ambient temperature : - 54°C to +121°C

The supply electrical parameters shall not exceed ( $U \leq 30$  V,  $I \leq 200$  mA,  $P \leq 1$  W,  $C \leq 5$  nF,  $L \approx 0$ ).

Concerning the use of the Pressure Sensor, see instruction manual of the manufacturer.



CSA INTERNATIONAL

# Certificate of Compliance

**Certificate:** 1420405 (LR 103016-10)

**Master Contract:** 184981

**Project:** 1844878

**Date Issued:** 2006/10/23

**Issued to:** Industrial Monitoring Instr. (IMI)

A Div. of PCB Piezotronics, Inc.  
3425 Walden Ave  
Depew, NY 14043  
USA  
Attention: Richard Furner

*The products listed below are eligible to bear the CSA Mark shown with adjacent indicators 'C' and 'US'*



**Issued by:** Ron Wildish

**Authorized by:** Patricia Pasemko, Operations Manager

## **PRODUCTS**

**CLASS 2258 84** - PROCESS CONTROL EQUIPMENT - Intrinsicly Safe, Entity - - For Hazardous Locations - Certified to US Standards

**CLASS 2258 04** - PROCESS CONTROL EQUIPMENT - Intrinsicly Safe, Entity - For Hazardous Locations

Class I, Div. 1, Groups A, B, C and D:

Exia IIC T4; Class I, Zone 0:

AEx ia IIC T4; Class I, Zone 0:

The 'C' and 'US' indicators adjacent to the CSA Mark signify that the product has been evaluated to the applicable CSA and ANSI/UL Standards, for use in Canada and the U.S., respectively. This 'US' indicator includes products eligible to bear the 'NRTL' indicator. NRTL, i.e. National Recognized Testing Laboratory, is a designation granted by the U.S. Occupational Safety and Health Administration (OSHA) to laboratories which have been recognized to perform certification to U.S. Standards.

**PCB Cont. No. 23498-C**





**Certificate:** 1420405 (LR 103016-10)

**Master Contract:** 184981

**Project:** 1844878

**Date Issued:** 2006/10/23

---

- Models 1xxAyyy, 1xxByyy and 1xxMyyy Pressure Sensors, input rated 28 Vdc max, 20 mA max; intrinsically safe with entity parameters of:  $V_{max}/U_i = 30V$ ,  $I_{max}/I_i = 200mA$ ,  $L_i = 0$ ,  $C_i = 5 \text{ nF}$ ; when installed per installation Dwg. 21869; Temp. Code T4 @ Max Ambient 121 Deg C.

Notes:

1. The "xx" in the model number denotes frequency response.
2. The "yyy" in the model number denotes minor mechanical mounting variations, variations in pressure range and variations in low frequency response.

#### **APPLICABLE REQUIREMENTS**

CSA Std C22.2 No. 142-M1987 - Process Control Equipment

CAN/CSA-C22.2 No. 157-92 - Intrinsically Safe and Non-Incendive Equipment for Use in Hazardous Locations

UL Std No. 913 - Intrinsically Safe Apparatus and Associated Apparatus for Use in Class I, II and III, Division 1, Hazardous Locations

UL Std No. 916 - Energy Management Equipment

CAN/CSA-E60079-0:02 - Electrical Apparatus for Explosive Gas Atmospheres - Part 0: General Requirements

CAN/CSA-E60079-11:02 - Electrical apparatus for Explosive Gas Atmospheres - Part 11: Intrinsic Safety "i"

ANSI/UL 60079-0:02 - Electrical Apparatus for Explosive Gas Atmospheres - Part 0: General Requirements

ANSI/UL 60079-11:02 - Electrical apparatus for Explosive Gas Atmospheres - Part 11: Intrinsic Safety "i"

**CLASS 2258 03 - PROCESS CONTROL EQUIPMENT - Intrinsically Safe and Non-Incendive Systems - For Hazardous Locations**

**CLASS 2258 83 - PROCESS CONTROL EQUIPMENT - Intrinsically Safe and Non-Incendive Systems - For Hazardous Locations - CERTIFIED TO U.S. STANDARDS**

Ex nL IICT4; Class I, Zone 2:

AEx nA IICT4: Class I, Zone 2:

Class I, Div. 2, Groups A, B, C, D:

- Models 1xxAyyy, 1xxByyy and 1xxMyyy Pressure Sensors, input rated 28 Vdc max, 20 mA max; non-incendive,



CSA INTERNATIONAL

**Certificate:** 1420405 (LR 103016-10)

**Master Contract:** 184981

**Project:** 1844878

**Date Issued:** 2006/10/23

---

with entity parameters of:  $V_{max}/U_i = 30V$ ,  $I_{max}/I_i = 200mA$ ,  $L_i = 0$ ,  $C_i = 5 nF$ ; when installed per installation Dwg. 21869; Temp. Code T4 @ Max Ambient 121 Deg C.

Notes:

1. The "xx" in the model number denotes frequency response.
2. The "yyy" in the model number denotes minor mechanical mounting variations, variations in pressure range and variations in low frequency response.
3. For Canadian Installations, sensor case must be bonded to ground according to Section 18-182 of the CEC, Part 1.
4. For US Installations, sensor case must be bonded to ground according to Article 501.16 of the NEC.

**APPLICABLE REQUIREMENTS**

CSA Std C22.2 No. 142-M1987 - Process Control Equipment

CSA Std. C22.2 No. 213-M1987 - Non-incendive Electrical Equipment for Use in Class I, Division 2 Hazardous Locations

UL Std No. 916 - Energy Management Equipment

FM Std. No. 3600-1998 - Electrical Equipment for Use in Hazardous (Classified) Locations – General Requirements

FM Std. No. 3611-1999 - Nonincendive Electrical Equipment for Use in Class I and II, Division 2, and Class III, Divisions 1 and 2, Hazardous (Classified) Locations

CAN/CSA-E60079-15:02 - Electrical apparatus for Explosive Gas Atmospheres - Part 15: Type of Protection "n"

ANSI/UL 60079-15:02 - Electrical apparatus for Explosive Gas Atmospheres - Part 15: Electrical Apparatus with Type of Protection "n"



## *Supplement to Certificate of Compliance*

Certificate: 1420405

Master Contract: 184981

*The products listed, including the latest revision described below, are eligible to be marked in accordance with the referenced Certificate.*

### Product Certification History

---

<b>Project</b>	<b>Date</b>	<b>Description</b>
1844878	2006/10/23	Update to cover minor drawing Revisions.
1697653	2005/08/04	Update to Include Zone 0, Zone 2, and Div. 2 Certification; model # change to 1xxAyyy, 1xxByyy and 1xxMyyy.
1612847	2004/11/09	Update of report to cover modifications to existing Amplifier, and addition of new Amplifier

### History

1420405; June 20, 2003; Update to include entire 102Mxxx Seires. Delisting of model 100M34.

LR 103164-15; Nov. 5, 1998; Update to cover report corrections.

LR 103164-10; Mar. 25, 1998; Original Certification – Models 102M206 and 100M34.



LCIE

1 **AVENANT D'ATTESTATION D'EXAMEN CE DE TYPE**

2 **Appareil ou système de protection** destiné à être utilisé en atmosphères explosibles (**Directive 94/9/CE**)

3 Numéro de l'avenant :  
**LCIE 06 ATEX 6103 X / 01**

4 Appareil ou système de protection :  
Capteur de pression  
Type : 1xxAyyy, 1xxByyy, 1xxMyyy

5 Demandeur : PCB Piezotronics Inc  
3425 Walden Avenue,  
Depew, New York 14043 - USA

15 **DESCRIPTION DE L'AVENANT**

- Mise à jour normative selon les normes EN 60079-0:2012 et EN 60079-15:2010.

Les résultats des vérifications et essais figurent dans le rapport confidentiel N° 121606-643052-02.

Paramètres spécifiques du ou des modes de protection concerné(s) :

$U \leq 30 \text{ V}$ ,  $I \leq 200 \text{ mA}$ ,  $P \leq 1 \text{ W}$ ,  $C \leq 5 \text{ nF}$ ,  $L \approx 0$

Le marquage doit être :

Modifié comme suit :

PCB

Adresse : ...

Type: 1xxAyyy, 1xxByyy or 1xxMyyy

N° de fabrication : ...

Année de fabrication : ...

Ⓔ II 3 G

Ex nA IIC T4 Gc

LCIE 06 ATEX 6103 X

Température ambiante : - 54°C à +121°C

**AVERTISSEMENT—NE PAS SÉPARER SOUS TENSION.**

16 **DOCUMENTS DESCRIPTIFS**

Dossier de certification N° 35706 rév.A du 02/07/2013.  
Ce dossier comprend 22 rubriques (25 pages).

17 **CONDITIONS SPECIALES POUR UNE UTILISATION SURE**

Inchangées.

18 **EXIGENCES ESSENTIELLES DE SECURITE ET DE SANTE**

Couvertes par les normes EN 60079-0:2012 et EN 60079-15:2010.

19 **VERIFICATIONS ET ESSAIS INDIVIDUELS**

Néant.

Fontenay-aux-Roses, le 29 novembre 2013

1 **SUPPLEMENTARY EC TYPE EXAMINATION CERTIFICATE**

2 **Equipment or protective system** intended for use in potentially explosive atmospheres (**Directive 94/9/EC**)

3 Supplementary certificate number :  
**LCIE 06 ATEX 6103 X / 01**

4 Equipment or protective system :  
Pressure Sensor  
Type : 1xxAyyy, 1xxByyy, 1xxMyyy

5 Applicant : PCB Piezotronics Inc  
3425 Walden Avenue,  
Depew, New York 14043 - USA

15 **DESCRIPTION OF THE SUPPLEMENTARY CERTIFICATE**

- Normative update according to EN 60079-0:2012 and EN 60079-15:2010 standards.

The examination and test results are recorded in confidential report N° 121606-643052-02.

Specific parameters of the concerned protection mode:

$U \leq 30 \text{ V}$ ,  $I \leq 200 \text{ mA}$ ,  $P \leq 1 \text{ W}$ ,  $C \leq 5 \text{ nF}$ ,  $L \approx 0$

The marking shall be :

Modified as following :

PCB

Address: ...

Type: 1xxAyyy, 1xxByyy or 1xxMyyy

Serial number: ...

Year of construction : ...

Ⓔ II 3 G

Ex nA IIC T4 Gc

LCIE 06 ATEX 6103 X

Ambient temperature : - 54°C to +121°C

**WARNING – DO NOT SEPARATE WHEN ENERGIZED.**

16 **DESCRIPTIVE DOCUMENTS**

Certification file N° 35706 rev.A dated 2013/07/02.  
This file includes 22 items (25 pages).

17 **SPECIAL CONDITIONS FOR SAFE USE**

Unchanged.

18 **ESSENTIAL HEALTH AND SAFETY REQUIREMENTS**

Covered by EN 60079-0:2012 and EN 60079-15:2010 standards.

19 **ROUTINE VERIFICATIONS AND TESTS**

None.

Le Responsable de Certification ATEX  
ATEX Certification Officer  
Julien GAUTHIER

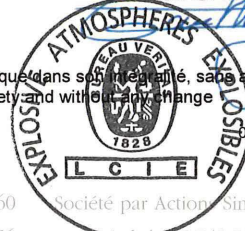

Seul le texte en français peut engager la responsabilité du LCIE. Ce document ne peut être reproduit que dans son intégralité, sans aucune modification.  
The LCIE's liability applies only on the French text. This document may only be reproduced in its entirety and with no change

Page 1 sur 1

A-Annexe III\_CE\_typ\_app\_av - rev3.DOC



**LCIE**

**1 ATTESTATION D'EXAMEN DE TYPE**

2 **Appareil ou système de protection** destiné à être utilisé en atmosphères explosibles (**Directive 94/9/CE**)

3 Numéro de l'attestation d'examen de type  
**LCIE 06 ATEX 6103 X**

4 Appareil ou système de protection :  
Transmetteur de pression  
Type : 1xxAyyy, 1xxByyy, 1xxMyyy

5 Demandeur : PCB Piezotronics Inc.  
Adresse : 3425 Walden avenue  
Depew, New York 14043  
USA

7 Cet appareil ou système de protection et ses variantes éventuelles acceptées sont décrits dans l'annexe de la présente attestation et dans les documents descriptifs cités en référence.

8 Le LCIE certifie que cet appareil ou système de protection est conforme aux exigences essentielles de sécurité et de santé pour la conception et la construction d'appareils et de systèmes de protection destinés à être utilisés en atmosphères explosibles, données dans l'annexe II de la directive 94/9/CE du Parlement européen et du Conseil du 23 mars 1994.

Les résultats des vérifications et essais figurent dans le rapport confidentiel N° 60051173/551969.

9 Le respect des exigences essentielles de sécurité et de santé est assuré par la conformité à :  
- EN 60079-0 (2004)  
- EN 60079-15 (2005)

10 Le signe X lorsqu'il est placé à la suite du numéro de l'attestation, indique que cet appareil ou système de protection est soumis aux conditions spéciales pour une utilisation sûre, mentionnées dans l'annexe de la présente attestation.

11 Cette attestation d'examen de type concerne uniquement la conception et la construction de l'appareil ou du système de protection spécifié, conformément à l'annexe III de la directive 94/9/CE.

Des exigences supplémentaires de la directive sont applicables pour la fabrication et la fourniture de l'appareil ou du système de protection. Ces dernières ne sont pas couvertes par la présente attestation.

12 Le marquage de l'appareil ou du système de protection doit comporter les informations détaillées au point 15.

**1 TYPE EXAMINATION CERTIFICATE**

2 **Equipment or protective system** intended for use in potentially explosive atmospheres (**Directive 94/9/EC**)

3 Type Examination Certificate number  
**LCIE 06 ATEX 6103 X**

4 Equipment or protective system :  
Pressure transmitter  
Type : 1xxAyyy, 1xxByyy, 1xxMyyy

5 applicant : PCB Piezotronics Inc.  
Address : 3425 Walden avenue  
Depew, New York 14043  
USA

7 This equipment or protective system and any acceptable variation thereto is specified in the schedule to this certificate and the documents therein referred to.

8 LCIE certifies that this equipment or protective system has been found to comply with the essential Health and Safety Requirements relating to the design and construction of equipment and protective system intended for use in potentially explosive atmospheres, given in Annex II of the Directive 94/9/EC of the European Parliament and Council of 23 March 1994.

The examination and test results are recorded in confidential report N° 60051173/551969.

9 Compliance with the Essential Health and Safety Requirements has been assured by compliance with :  
- EN 60079-0 (2004)  
- EN 60079-15 (2005)

10 If the sign X is placed after the certificate number, it indicates that the equipment or protective system is subject to special conditions for safe use specified in the schedule to this certificate.

11 This type examination certificate relates only to the design and construction of this specified equipment or protective system in accordance with annex III to the directive 94/9/EC.

Further requirements of the Directive apply to the manufacture and supply of this equipment or protective system. These are not covered by this certificate.

12 The marking of the equipment or protective system shall include informations as detailed at 15.

Fontenay-aux-Roses, le 13 novembre 2006

Marc GILLAUX  
  
Le responsable de certification ATEX  
ATEX certification manager

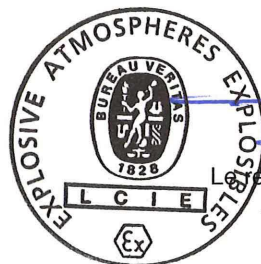

Seul le texte en français peut engager la responsabilité du LCIE. Ce document ne peut être reproduit que dans son intégralité, sans aucune modification  
The LCIE's liability applies only on the French text. This document may be reproduced in its entirety and without any change

13 ANNEXE

13 SCHEDULE

14 ATTESTATION D'EXAMEN DE TYPE

14 TYPE EXAMINATION CERTIFICATE

LCIE 06 ATEX 6103 X

LCIE 06 ATEX 6103 X

15 DESCRIPTION DE L'APPAREIL OU DU SYSTEME DE PROTECTION

15 DESCRIPTION OF EQUIPMENT OR PROTECTIVE SYSTEM

Transmetteur de pression  
Type : 1xxAyyy, 1xxByyy, 1xxMyyy

Pressure transmitter  
Type : 1xxAyyy, 1xxByyy, 1xxMyyy

Ce matériel est composé d'un ensemble piézoélectrique, d'un amplificateur de charge et d'un connecteur. L'ensemble est monté dans une enveloppe métallique.

This apparatus is made of a piezo-crystal assembly, a charge amplifier and a connector. The assembly is mounted inside a metallic enclosure.

Paramètres spécifiques du ou des modes de protection concernés :

Specific parameters of the mode(s) of protection concerned :

$U \leq 30 \text{ V}$  ,  $I \leq 200 \text{ mA}$  ,  $P \leq 1 \text{ W}$  ,  $C \leq 5 \text{ nF}$  ,  $L \approx 0$

$U \leq 30 \text{ V}$  ,  $I \leq 200 \text{ mA}$  ,  $P \leq 1 \text{ W}$  ,  $C \leq 5 \text{ nF}$  ,  $L \approx 0$

Le marquage doit être :

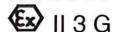
PCB Piezotronics Inc.  
Adresse : ...  
Type : 1xxAyyy, 1xxByyy ou 1xxMyyy  
N° de fabrication : ...  
Année de fabrication : ...  
 II 3 G  
Ex nA IIC T4  
LCIE 06 ATEX 6103 X  
Tamb. : - 54°C à + 121°C

The marking shall be :

PCB Piezotronics Inc.  
Address : ...  
Type : 1xxAyyy, 1xxByyy or 1xxMyyy  
Serial number : ...  
Year of manufacturing : ...  
 II 3 G  
Ex nA IIC T4  
LCIE 06 ATEX 6103 X  
Tamb. : - 54°C to + 121°C

L'appareil doit également comporter le marquage normalement prévu par les normes de construction qui le concerne.

The equipment shall also bear the usual marking required by the manufacturing standards applying to such equipment.

16 DOCUMENTS DESCRIPTIFS

16 DESCRIPTIVE DOCUMENTS

Dossier de certification N° 35706 du 16/10/2006.  
Ce document comprend 22 rubriques (25 pages).

Certification file N° 35706 dated 16/10/2006.  
This file includes 22 items (25 pages).

17 CONDITIONS SPECIALES POUR UNE UTILISATION SÛRE

17 SPECIAL CONDITIONS FOR SAFE USE

Les paramètres électriques d'alimentation ne doivent pas excéder les valeurs mentionnées au paragraphe 15.

The supply electrical parameters shall not exceed the values mentioned in paragraph 15.

18 EXIGENCES ESSENTIELLES DE SECURITE ET DE SANTE

18 ESSENTIAL HEALTH AND SAFETY REQUIREMENTS

Couvertes par les normes listées au point 9.

Covered by standards listed at 9.

19 VERIFICATIONS ET ESSAIS INDIVIDUELS

19 ROUTINE VERIFICATIONS AND TESTS

Néant.

None.

## EU Declaration of Conformity PS059

*In Accordance with ISO/IEC 17050*

**Manufacturer:**  
 PCB Piezotronics, Inc.  
 3425 Walden Avenue  
 Depew, New York 14043  
 USA

**Authorized European Representative:**  
 PCB Piezotronics Europe GmbH  
 Porschestraße 20-30  
 41836 Hückelhoven  
 Germany

**Certifies that type of equipment:**      **Pressure Sensors(s)**  
**Whose Product Models Include:**      **1xxAyy, 1xxByy, 1xxMyy Series**

Note:      "xx,"      is a place holder for two numbers.  
              "yy,"      is a place holder for two numbers.

These letters and numbers are included in the model numbers of the series. For details see the related data sheets.

**This declaration is applicable to all Pressure Sensor(s) of the above series which have the CE & (EX) ATEX mark on their data sheets and where those data sheets refer to this declaration of conformity. The data sheets for all model numbers referenced above, which include the CE & (EX) ATEX mark on such data sheets and refer to this Declaration of Conformity are hereby incorporated by reference into this Declaration.**

<b>Conform to the following EU Directive(s) when installed per product documentation:</b>	2014/30/EU 2011/65/EU w/2015/863/EU 2014/34/EU	EMC Directive RoHS Directive ATEX Directive
---	--	---

### Standards to which Conformity is Declared:

<b>Harmonized Standards</b>	EN 61326-1:2013  EN 61326-2-3: 2013  EN 61010-1:2010 EN 61010-1:2010/A1:2019/AC:2019-04 EN 61010-1:2010/A1:2019  EN 60079-0:2018  EN 60079-11: 2012  EN 63000:2018	Electrical Equipment for Measurement, Control and Laboratory Use- EMC requirements - Part 1: General requirements  Electrical equipment for measurement, control and laboratory use - EMC requirements - Part 2-3: Particular requirements - Test configuration, operational conditions and performance criteria for transducers with integrated or remote signal conditioning  Safety Requirements for Electrical Equipment for Measurement, Control, and Laboratory Use - Part 1: General Requirements  General Explosive Atmosphere  Intrinsic safe, i  Technical documentation for the assessment of electrical and electronic products with respect to the restriction of hazardous substances (IEC 63000:2016)
<b>Emissions Test Standards</b>	EN 55011:2016, EN 55011:2016/A1:2017 EN 55011:2016/A11:2020	Industrial, scientific and medical (ISM) radio frequency equipment-Electromagnetic disturbance characteristics- Limits and methods of Measurement Class B
<b>Other Standards Applied (non-OJEU) Immunity Test Standards</b>	EN 61000-4-2:2001  EN 61000-4-3:2006  EN 61000-4-4:2004	Electromagnetic compatibility (EMC)-Part 4-2: Testing and measuring techniques- Electrostatic discharge immunity test  Electromagnetic compatibility (EMC) - Part 4-3: Testing and measurement techniques - Radiated, radio-frequency, electromagnetic field immunity test  Electromagnetic compatibility (EMC) - Part 4-4: Testing and measurement techniques - Electrical fast transient/burst immunity test

	EN 61000-4-5:2005 EN 61000-4-6:2006 EN 61000-4-8:2001  EN 61000-6-1:2007  EN 61000-6-2:2005 EN 61000-6-2:2005/ AC:2005	Electromagnetic compatibility (EMC) - Part 4-5: Testing and measurement techniques - Surge immunity test Electromagnetic compatibility (EMC) - Part 4-6: Testing and measurement techniques - Immunity to conducted disturbances, induced by radio-frequency fields Electromagnetic compatibility (EMC) – Part 4-8: Testing and measurement techniques – Power frequency magnetic field immunity test  Electromagnetic Compatibility (EMC) - Generic standards — Immunity for residential, commercial and light-industrial environments  Electromagnetic compatibility (EMC) — Part 6-2: Generic standards — Immunity for industrial environments
<b>Test Reports</b>	EMC Reports Safety Reports	GM29034c GM29035s
<b>EC Type Examination</b>	ATEX Certification	LCIE 03 ATEX 6279 X Ex ia IIC T4, II 1G LCIE 06 ATEX 6103 X Ex nA IIC T4, II 3G
<b>Other International Certifications</b>	IECEX Certifications	IECEX LCIE 13.0065 X Ex ia IIC T4 Ga Ui : 30V, li : 200mA, Pi : 1 W, Ci : 5nF, Li: 0 mH  IECEX LCIE 13.0066 X Ex nA IIC T4 Gc
<b>Notified Body Name</b>		Laboratoire Central des Industries Electriques (0081)
<b>Notified Body's Address</b>		<b>FONTENAY-AUX-ROSES (Head Office)</b> 33, avenue du Général Leclerc FR- 92260 Fontenay-aux-Roses Tel. : + 33 1 40 95 60 60 Fax : + 33 1 40 95 86 56

*I, the undersigned, hereby declare that the equipment specified above conforms to the above Directive(s) Standard(s)*

**Place:** Depew, NY **Date:** 06/8/2023

Signature: 

Name: Wendy Willard

Title: Regulatory Affairs and Product Certification Specialist



## UK Declaration of Conformity PS059UK

*In Accordance with ISO/IEC 17050*

**Manufacturer:**  
PCB Piezotronics, Inc.  
3425 Walden Avenue  
Depew, New York 14043  
USA

**Authorized UK Representative:**  
PCB Piezotronics Ltd  
Business and Technology Center  
Bessemer Drive  
Stevenage  
Hertfordshire, SG1 2DX  
United Kingdom



**Certifies that type of equipment:**      **Pressure Sensor(s)**

**Whose Product Models Include:**      **1xxAyy, 1xxByy, 1xxMyy Series**

Note:      "xx,"      is a place holder for two numbers.  
             "yy,"      is a place holder for two numbers.

These letters and numbers are included in the model numbers of the series. For details see the related data sheets.

**This declaration is applicable to all Pressure Sensor(s) of the above series which have the UKCA & (EX) ATEX mark on their data sheets and where those data sheets refer to this declaration of conformity. The data sheets for all model numbers referenced above, which include the UKCA & (EX) ATEX mark on such data sheets and refer to this Declaration of Conformity are hereby incorporated by reference into this Declaration.**

**Conform to the following UK Statutory Requirements when installed per product documentation:**

Electromagnetic Compatibility Regulations 2016 (SI 2016 No. 1091) Electrical Equipment (Safety) Regulations 2016  
The Restriction of the Use of Certain Hazardous Substances in Electrical and Electronic Equipment Regulations 2012 (SI 2012 No. 3032,)

### Designated Standards to which Conformity is Declared:

<b>Designated Standards</b>	BS EN 61326-1:2013  BS EN 61326-2-3: 2013  BS EN 61010-1:2010 BS EN 61010-1:2010/A1:2019/AC:2019-04 BS EN 61010-1:2010/A1:2019  BS EN IEC 63000:2018	Electrical Equipment for Measurement, Control and Laboratory Use- EMC requirements - Part 1: General requirements  Electrical equipment for measurement, control and laboratory use - EMC requirements - Part 2-3: Particular requirements - Test configuration, operational conditions and performance criteria for transducers with integrated or remote signal conditioning  Safety Requirements for Electrical Equipment for Measurement, Control, and Laboratory Use - Part 1: General Requirements  Technical documentation for the assessment of electrical and electronic products with respect to the restriction of hazardous substances (IEC 63000:2016)
<b>Emissions Test Standards</b>	BS EN 55011:2016, BS EN 55011:2016/A1:2017 BS EN 55011:2016/A11:2020	Industrial, scientific and medical (ISM) radio frequency equipment-Electromagnetic disturbance characteristics- Limits and methods of Measurement Class B
<b>Other Standards Applied (non-OJEU) Immunity Test Standards</b>	BS EN 61000-4-2:2001  BS EN 61000-4-3:2006  BS EN 61000-4-4:2004  BS EN 61000-4-5:2005	Electromagnetic compatibility (EMC)-Part 4-2: Testing and measuring techniques- Electrostatic discharge immunity test  Electromagnetic compatibility (EMC) - Part 4-3: Testing and measurement techniques - Radiated, radio-frequency, electromagnetic field immunity test  Electromagnetic compatibility (EMC) - Part 4-4: Testing and measurement techniques - Electrical fast transient/burst immunity test  Electromagnetic compatibility (EMC) - Part 4-5: Testing and measurement techniques - Surge immunity test

	BS EN 61000-4-6:2006	Electromagnetic compatibility (EMC) - Part 4-6: Testing and measurement techniques - Immunity to conducted disturbances, induced by radio-frequency fields
	BS EN 61000-4-8:2001	Electromagnetic compatibility (EMC) – Part 4-8: Testing and measurement techniques – Power frequency magnetic field immunity test
	BS EN 61000-6-1:2007	Electromagnetic Compatibility (EMC) - Generic standards — Immunity for residential, commercial and light-industrial environments
	BS EN 61000-6-2:2005 BS EN 61000-6-2:2005/ AC:2005	Electromagnetic compatibility (EMC) — Part 6-2: Generic standards — Immunity for industrial environments
<b>Test Reports</b>	EMC Reports Safety Reports	GM29034c GM29035s

*I, the undersigned, hereby declare that the equipment specified above conforms to the above Directive(s) Standard(s)*

**Place:** Depew, NY **Date:** 06/6/2023

Signature: 

Name: Wendy Willard

Title: Regulatory Affairs and Product Certification Specialist



**L C I E**

**1 AVENANT D'ATTESTATION D'EXAMEN CE DE TYPE**

**2 Appareil ou système de protection** destiné à être utilisé en atmosphères explosibles (**Directive 94/9/CE**)

**3** Numéro de l'avenant :  
**LCIE 03 ATEX 6279 X / 04**

**4** Appareil ou système de protection :  
Capteur de pression  
Type : 1xxAyyy, 1xxByyy, 1xxMyyy

**5** Demandeur : PCB Piezotronics Inc  
3425 Walden Avenue,  
Depew, New York 14043 - USA

**15 DESCRIPTION DE L'AVENANT**

- Mise à jour normative selon les normes EN 60079-0:2012 et EN 60079-11:2012.

Les résultats des vérifications et essais figurent dans le rapport confidentiel N° 121606-643052-01.

Paramètres spécifiques du ou des modes de protection concerné(s) :

$U_i$  : 30 V,  $I_i$  : 200 mA,  $P_i$  : 1 W,  $C_i$  : 5 nF,  $L_i$  : 0

Le marquage doit être :

Modifié comme suit :

PCB

Adresse : ...

Type: 1xxAyyy, 1xxByyy or 1xxMyyy

N° de fabrication : ...

Année de fabrication : ...

Ⓢ II 1 G

Ex ia IIC T4 Ga

LCIE 03 ATEX 6279 X

$U_i$  : 30 V,  $I_i$  : 200 mA,  $P_i$  : 1 W,  $C_i$  : 5 nF,  $L_i$  : 0

Température ambiante : - 54°C à +121°C

**16 DOCUMENTS DESCRIPTIFS**

Dossier de certification N° 23208 rév.D du 02/07/2013.  
Ce dossier comprend 22 rubriques (25 pages).

**17 CONDITIONS SPECIALES POUR UNE UTILISATION SURE**

Inchangées.

**18 EXIGENCES ESSENTIELLES DE SECURITE ET DE SANTE**

Couvertes par les normes EN 60079-0:2012 et EN 60079-11:2012.

**19 VERIFICATIONS ET ESSAIS INDIVIDUELS**

Néant.

Fontenay-aux-Roses, le 29 novembre 2013

**1 SUPPLEMENTARY EC TYPE EXAMINATION CERTIFICATE**

**2 Equipment or protective system** intended for use in potentially explosive atmospheres (**Directive 94/9/EC**)

**3** Supplementary certificate number :  
**LCIE 03 ATEX 6279 X / 04**

**4** Equipment or protective system :  
Pressure Sensor  
Type : 1xxAyyy, 1xxByyy, 1xxMyyy

**5** Applicant : PCB Piezotronics Inc  
3425 Walden Avenue,  
Depew, New York 14043 - USA

**15 DESCRIPTION OF THE SUPPLEMENTARY CERTIFICATE**

- Normative update according to EN 60079-0:2012 and EN 60079-11:2012 standards.

The examination and test results are recorded in confidential report N° 121606-643052-01.

Specific parameters of the concerned protection mode:

$U_i$  : 30 V,  $I_i$  : 200 mA,  $P_i$  : 1 W,  $C_i$  : 5 nF,  $L_i$  : 0

The marking shall be :

Modified as following :

PCB

Address: ...

Type: 1xxAyyy, 1xxByyy or 1xxMyyy

Serial number: ...

Year of construction : ...

Ⓢ II 1 G

Ex ia IIC T4 Ga

LCIE 03 ATEX 6279 X

$U_i$  : 30 V,  $I_i$  : 200 mA,  $P_i$  : 1 W,  $C_i$  : 5 nF,  $L_i$  : 0

Ambient temperature : - 54°C to +121°C

**16 DESCRIPTIVE DOCUMENTS**

Certification file N° 23208 rev.D dated 2013/07/02.  
This file includes 22 items (25 pages).

**17 SPECIAL CONDITIONS FOR SAFE USE**

Unchanged.

**18 ESSENTIAL HEALTH AND SAFETY REQUIREMENTS**

Covered by EN 60079-0:2012 and EN 60079-11:2012 standards.

**19 ROUTINE VERIFICATIONS AND TESTS**

None.

Le Responsable de Certification ATEX  
ATEX Certification Officer

Julien GAUTHIER



Seul le texte en français peut engager la responsabilité du LCIE. Ce document ne peut être reproduit que dans son intégralité, sans aucune modification.  
The LCIE's liability applies only on the French text. This document may only be reproduced in its entirety and without any change.

Page 1 sur 1

01A-Annexe III\_CE\_typ\_app\_av - rev3.DOC



**L C I E**

**1 AVENANT D'ATTESTATION D'EXAMEN CE DE TYPE**

**2 Appareil ou système de protection** destiné à être utilisé en atmosphères explosibles (**Directive 94/9/CE**)

3 Numéro de l'avenant :  
**LCIE 03 ATEX 6279 X / 03**

4 Appareil ou système de protection :  
Transmetteur de pression  
Type : 1xxAyyy, 1xxByyy, 1xxMyyy

5 Demandeur : PCB PIEZOTRONICS Inc.

**15 DESCRIPTION DE L'AVENANT**

- Certification suivant les normes EN 60079-0 (2004) et EN 60079-11 (2006)
- Mise à jour des schémas.

Les résultats des vérifications et essais figurent dans le rapport confidentiel N° 60051175/551970.

Paramètres spécifiques du ou des modes de protection concerné(s) :

Inchangés.

Le marquage doit être :

Modifié comme suit : Ex ia IIC T4

**16 DOCUMENTS DESCRIPTIFS**

Dossier de certification N° 23208 rev.C du 19/09/2006. Ce dossier comprend 22 rubriques (25 pages).

**17 CONDITIONS SPECIALES POUR UNE UTILISATION SURE**

Inchangées.

**18 EXIGENCES ESSENTIELLES DE SECURITE ET DE SANTE**

Modifiées comme suit :  
Conformité aux normes Européennes EN 60079-0 (2004) et EN 60079-11 (2006).

**19 VERIFICATIONS ET ESSAIS INDIVIDUELS**

Inchangées.

Fontenay-aux-Roses, le 13 novembre 2006

**1 SUPPLEMENTARY EC TYPE EXAMINATION CERTIFICATE**

**2 Equipment or protective system** intended for use in potentially explosive atmospheres (**Directive 94/9/EC**)

3 Supplementary certificate number :  
**LCIE 03 ATEX 6279 X / 03**

4 Equipment or protective system :  
Pressure transmitter  
Type : 1xxAyyy, 1xxByyy, 1xxMyyy

5 Applicant : PCB PIEZOTRONICS Inc

**15 DESCRIPTION OF THE SUPPLEMENTARY CERTIFICATE**

- Certification following the EN 60079-0 (2004) and EN 60079-11 (2006) standards.
- Update drawings.

The examination and test results are recorded in confidential report N° 60051175/551970.

Specific parameters of the mode(s) of protection concerned:

Unchanged.

The marking shall be :

Modified as follows : Ex ia IIC T4

**16 DESCRIPTIVE DOCUMENTS**

Certification file N° 23208 rev.C dated 19/09/2006. This file includes 22 items (25 pages).

**17 SPECIAL CONDITIONS FOR SAFE USE**

Unchanged.

**18 ESSENTIAL HEALTH AND SAFETY REQUIREMENTS**

Modified as follows :  
Conformity to the European standards EN 60079-0 (2004) and EN 60079-11 (2006).

**19 ROUTINE VERIFICATIONS AND TESTS**

Unchanged.

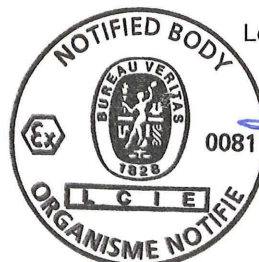

Le responsable de certification ATEX  
ATEX certification manager

Marc GILLAUX

Seul le texte en français peut engager la responsabilité du LCIE. Ce document ne peut être reproduit que dans son intégralité, sans aucune modification. The LCIE's liability applies only on the French text. This document may only be reproduced in its entirety and without any change.



L C I E

(A1) **ATTESTATION D'EXAMEN CE DE TYPE  
LCIE 03 ATEX 6279 X du 22 juillet 2003**

(A1) **EC TYPE EXAMINATION CERTIFICATE  
LCIE 03 ATEX 6279 X dated July 22<sup>nd</sup>, 2003**

**AVENANT 03 ATEX 6279 X/02**

**VARIATION 03 ATEX 6279 X/02**

(A2) DESIGNATION DE L'EQUIPEMENT OU DU SYSTEME  
DE PROTECTION :

(A2) NAME OF EQUIPMENT OR PROTECTIVE SYSTEM :

Transmetteur de pression  
Type : 1xxAyyy, 1xxByyy ou 1xxMyyy

Pressure transmitter  
Type : 1xxAyyy, 1xxByyy or 1xxMyyy

Construit par :  
PCB PIEZOTRONICS Inc.

Manufactured by :  
PCB PIEZOTRONICS Inc.

(A3) OBJET DE L'AVENANT, DESCRIPTION DE  
L'APPAREIL OU DU SYTEME DE PROTECTION :

(A3) SUBJECT OF THE VARIATION, DESCRIPTION OF  
EQUIPMENT OR PROTECTIVE SYSTEM :

- Modification du type pour permettre de mieux définir les  
différentes variantes

-Modification of the type to more accurately define variations.

Le marquage est modifié comme suit :

The marking is modified as follows :

Type : 1xxAyyy, 1xxByyy ou 1xxMyyy

Type : 1xxAyyy, 1xxByyy or 1xxMyyy

Paramètres spécifiques du ou des modes de protection  
concerné(s) :

Specific parameters of the mode of protection concerned :

Inchangés.

Unchanged.

(A4) DOCUMENTS DESCRIPTIFS :

(A4) DESCRIPTIVE DOCUMENTS :

Dossier technique N°23208 Rév. B daté du 4 mai 2005.  
Ce document comprend 3 rubriques (4 pages).

Technical file No. 23208 Rev. B dated May 4<sup>th</sup>, 2005.  
This file includes 3 items (4 pages).

(A5) CONDITIONS SPECIALES POUR UNE UTILISATION  
SURE :

(A5) SPECIAL CONDITIONS FOR SAFE USE :

Inchangées.

Unchanged:

(A6) EXIGENCES ESSENTIELLES EN CE QUI  
CONCERNE LA SECURITE ET LA SANTE :

(A6) ESSENTIAL HEALTH AND SAFETY REQUI-REMENTS :

Inchangées.

Unchanged.

Fontenay-aux-Roses, le 31 août 2005

Le Directeur de l'organisme certificateur  
Manager of the certification body

P/O  
  
Timbre sec/Dry seal

Page 1/1

(8) Seul le texte en français peut engager la responsabilité du LCIE. Ce document ne peut être reproduit que dans son intégralité, sans aucune modification.  
The LCIE's liability applies only on the French text. This document may only be reproduced in full and without any change.



**L C I E**

(A1) **ATTESTATION D'EXAMEN CE DE TYPE  
LCIE 03 ATEX 6279 X du 22 juillet 2003**

**AVENANT 03 ATEX 6279 X / 01**

(A2) DESIGNATION DE L'EQUIPEMENT OU DU SYSTEME DE PROTECTION :

Capteurs de pression  
Type : 102Mxxx Series  
Construit par : PCB Piezotronics Inc.

(A3) OBJET DE L'AVENANT, DESCRIPTION DE L'APPAREIL OU SYSTEME DE PROTECTION :

Modification de l'assemblage de l'amplificateur 21760  
Ajout d'un assemblage amplificateur 28040 avec schema 28041

Marquage : Inchangé

(A4) DOCUMENTS DESCRIPTIFS :

Dossier technique N° 23208 Rév A du 1 octobre 2004.  
Ce document comprend 22 rubriques ( 25 pages).

(A5) CONDITIONS SPECIALES POUR UNE UTILISATION SURE :

Inchangées

(A6) EXIGENCES ESSENTIELLES EN CE QUI CONCERNE LA SECURITE ET LA SANTE :

Inchangées

(A1) **EC TYPE EXAMINATION CERTIFICATE  
LCIE 03 ATEX 6279 X dated July 22<sup>th</sup>, 2003**

**VARIATION 03 ATEX 6279 X / 01**

(A2) DESIGNATION OF EQUIPMENT OR PROTECTIVE SYSTEM :

Pressure Sensors  
Type : 102Mxxx Series  
Manufactured by : PCB Piezotronics Inc.

(A3) SUBJECT OF THE VARIATION, DESCRIPTION OF EQUIPMENT OR PROTECTIVE SYSTEM :

Modification of amplifier 21760 assembly  
Add of amplifier 28040 assembly with 28041 schematic diagram

Marking : Unchanged

(A4) DESCRIPTIVE DOCUMENTS :

Technical file N° 23208 Rev A dated October 1<sup>st</sup>, 2004.  
This file includes 22 items (25 pages).

(A5) SPECIAL CONDITIONS FOR SAFE USE :

Unchanged

(A6) ESSENTIAL HEALTH AND SAFETY REQUIREMENTS :

Unchanged

Fontenay-aux-Roses, le 25 novembre 2004

Le Directeur de l'organisme certificateur  
Manager of the certification body

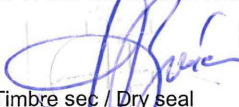
  
**Michel BRÉNON**

Timbre sec / Dry seal

LCIE  
Laboratoire Central  
des Industries Electriques  
Une société de Bureau Veritas

33, av du Général Leclerc  
BP 8  
92266 Fontenay-aux-Roses cedex  
France

Tél : +33 1 40 95 60 60  
Fax : +33 1 40 95 86 56  
contact@lcie.fr  
www.lcie.fr

Société Anonyme  
au capital de 15 745 984 €  
RCS Nanterre B 408 363 174



LCIE

1 ATTESTATION D'EXAMEN CE DE TYPE

2 Appareils et systèmes de protection destinés à être utilisés en atmosphères explosibles Directive 94/9/CE

3 Numéro de l'attestation d'examen CE de type LCIE 03 ATEX 6279 X

4 Appareil ou système de protection : Transmetteur de pression Type : 102Mxxx

5 Demandeur : PCB PIEZOTRONICS Inc.

6 Adresse : 3425 Walden Avenue Depew, New York 14043 U.S.A.

7 Cet appareil ou système de protection et ses variantes éventuelles acceptées est décrit dans l'annexe de la présente attestation et dans les documents descriptifs cités en annexe.

8 Le LCIE, organisme notifié sous la référence 0081 conformément à l'article 9 de la directive 94/9/CE du Parlement européen et du Conseil du 23 mars 1994, certifie que cet appareil ou système de protection est conforme aux exigences essentielles en ce qui concerne la sécurité et la santé pour la conception et la construction d'appareils et de systèmes de protection destinés à être utilisés en atmosphères explosibles, données dans l'annexe II de la directive. Les vérifications et épreuves figurent dans nos rapports confidentiels N° 41086010.

9 Le respect des exigences essentielles en ce qui concerne la sécurité et la santé est assuré par la conformité aux documents suivants : -EN 50014 (1997) + amendements 1 et 2, -EN 50020 (2002).

10 Le signe X lorsqu'il est placé à la suite du numéro de l'attestation, indique que ce matériel ou système de protection est soumis aux conditions spéciales pour une utilisation sûre, mentionnées dans l'annexe de la présente attestation.

11 Cette attestation d'examen CE de type concerne uniquement la conception et la construction de l'appareil ou du système de protection spécifié, conformément à la directive 94/9/CE. Des exigences supplémentaires de cette directive sont applicables pour la fabrication et la fourniture de l'appareil ou du système de protection.

12 Le marquage de l'appareil ou du système de protection devra comporter, entre autres indications utiles, les mentions suivantes :

Ex II 1 G EEx ia IIC T4

1 EC TYPE EXAMINATION CERTIFICATE

2 Equipment or protective system intended for use in potentially explosive atmospheres Directive 94/9/EC

3 EC type Examination Certificate number LCIE 03 ATEX 6279 X

4 Equipment or protective system : Pressure transmitter Type : 102Mxxx

5 Applicant : PCB PIEZOTRONICS Inc.

6 Address : 3425 Walden Avenue Depew, New York 14043 U.S.A.

7 This equipment or protective system and any acceptable variation thereto is specified in the schedule to this certificate and the documents therein referred to.

8 LCIE, notified body number 0081 in accordance with article 9 of the Directive 94/9/EC of the European Parliament and Council of 23 March 1994, certifies that this equipment or protective system has been found to comply with the essential Health and Safety Requirements relating to the design and construction of equipment and protective system intended for use in potentially explosive atmospheres, given in Annex II of the Directive. The examination and test results are recorded in confidential reports No. 41086010.

9 Compliance with the Essential Health and Safety Requirements has been assured by compliance with : -EN 50014 (1997) + amendments 1 and 2, -EN 50020 (2002).

10 If the sign X is placed after the certificate number, it indicates that the equipment or protective system is subject to special conditions for safe use specified in the schedule to this certificate.

11 This EC Type examination certificate relates only to the design and construction of this specified equipment or protective system in accordance with the Directive 94/9/EC. Further requirements of the Directive applies to the manufacture and supply of this equipment or protective system.

12 The marking of the equipment or protective system shall include the following :

Ex II 1 G EEx ia IIC T4

Fontenay-aux-Roses, le 22 juillet 2003

Le Directeur de l'organisme certificateur Manager of the certification body

Handwritten signature and 'Timbre sec / Dry seal' stamp

de

Seul le texte en français peut engager la responsabilité du LCIE. Ce document ne peut être reproduit que dans son intégralité, sans aucune modification The LCIE's liability applies only on the French text. This document may be reproduced in full and without any change



L C I E

(A1) ANNEXE

(A1) SCHEDULE

(A2) ATTESTATION D'EXAMEN CE DE TYPE

(A2) EC TYPE EXAMINATION CERTIFICATE

LCIE 03 ATEX 6279 X

LCIE 03 ATEX 6279 X

(A3) Description de l'équipement ou du système de protection :

(A3) Description of Equipment or Protective System :

Transmetteur de pression  
Type : 102Mxxx

Pressure transmitter  
Type : 102Mxxx

Ce matériel est composé d'un ensemble piézoélectrique, d'un amplificateur de charge et d'un connecteur.  
L'ensemble est monté dans une enveloppe métallique.

This apparatus is made of a piezo-crystal assembly, a charge amplifier and a connector.  
The assembly is mounted inside a metallic enclosure.

Le marquage est le suivant :

Marking is as follow :

PCB  
Adresse : ...  
Type : 102Mxxx (1)  
N° de fabrication : ...  
Année de fabrication : ...  
Ex II 1 G  
EEx ia IIC T4  
LCIE 03 ATEX 6279 X  
T.amb. : -54°C à +121°C

PCB  
Address : ...  
Type : 102Mxxx (1)  
Serial number : ...  
Year of manufacturing : ...  
Ex II 1 G  
EEx ia IIC T4  
LCIE 03 ATEX 6279 X  
T.amb. : -54°C to +121°C

(1) Suivant le modèle

(1) According to the model

Le marquage CE est accompagné du numéro d'identification de l'organisme notifié responsable de la surveillance du système approuvé de qualité (0081 pour le LCIE).

The CE marking shall be accompanied by the identification number of the notified body responsible for surveillance of the approved quality system (0081 for LCIE).

Le matériel devra également comporter le marquage normalement prévu par les normes de construction du matériel électrique concerné.

The equipment must also bear the usual marking required by the manufacturing standards applying to such equipments.

Paramètres électriques relatifs à la sécurité :

Electrical parameters relative to safety :

Ui = 30 V  
Ii = 200 mA  
Pi = 1 W  
Li = 0  
Ci = 5 nF

Ui = 30 V  
Ii = 200 mA  
Pi = 1 W  
Li = 0  
Ci = 5 nF





LCIE

(A1) **ANNEXE (suite)**

(A1) **SCHEDULE (continued)**

(A2) **ATTESTATION D'EXAMEN CE DE TYPE**

(A2) **EC TYPE EXAMINATION CERTIFICATE**

**LCIE 03 ATEX 6279 X**

**LCIE 03 ATEX 6279 X**

(A4) Documents descriptifs :

(A4) Descriptive documents :

Dossier technique N° 23208 Rév. NC du 18 juin 2003.  
Ce document comporte 19 rubriques (21 pages).

Technical file No. 23208 Rev. NC dated June 18<sup>th</sup>, 2003.  
This file includes 19 items (21 pages).

(A5) Conditions spéciales pour une utilisation sûre :

(A5) Special conditions for safe use :

Ce matériel est un appareil de sécurité intrinsèque, il peut être placé en atmosphère explosible.

This equipment is an intrinsically safe apparatus, it can be mounted in explosive atmosphere.

Le matériel ne doit être raccordé qu'à un matériel associé de sécurité intrinsèque certifié et cette association doit être compatible du point de vue sécurité intrinsèque.

The apparatus must be only connected to a certified associated intrinsically safe equipment and this combination must be compatible regarding intrinsic safety rules.

Les caractéristiques électriques du matériel associé de sécurité intrinsèque ne doivent excéder aucune des valeurs suivantes :

Electrical parameters of associated intrinsically safe equipment shall not exceed any of the following values :

$U_0 \leq 30 \text{ V}$ ,  $I_0 \leq 0,2 \text{ A}$ ,  $P_0 \leq 1 \text{ W}$

$U_0 \leq 30 \text{ V}$ ,  $I_0 \leq 0,2 \text{ A}$ ,  $P_0 \leq 1 \text{ W}$

(A6) Exigences essentielles en ce qui concerne la sécurité et la santé :

(A6) Essential Health and Safety Requirements :

Conformité aux normes européennes EN 50014 (1997 + amendements 1 et 2) et EN 50020 (2002).

Conformity to the European standards EN 50014 (1997 + amendments 1 and 2) and EN 50020 (2002).

Vérifications et épreuves individuelles :

Individual examinations and tests :

L'appareil est dispensé d'épreuve individuelle.

The equipment is not submitted to routine test.



# IECEX Certificate of Conformity

## INTERNATIONAL ELECTROTECHNICAL COMMISSION IEC Certification Scheme for Explosive Atmospheres

for rules and details of the IECEx Scheme visit [www.iecex.com](http://www.iecex.com)

Certificate No.: IECEx LCIE 13.0065X issue No.:1  
Status: **Current**  
Date of Issue: **2015-11-09** Page 1 of 4

Certificate history:  
Issue No. 1 (2015-11-9)  
Issue No. 0 (2013-11-29)

Applicant: **PCB Piezotronics**  
3425 Walden Avenue,  
Depew, New York 14043  
**United States of America**

Electrical Apparatus: **Pressure Sensor**  
Optional accessory: Type : 1xxAyyy, 1xxByyy or 1xxMyyy

Type of Protection: **Ex ia**

Marking: PCB Piezotronics  
Address : ...  
Type : 1xxAyyy, 1xxByyy or 1xxMyyy  
Serial number : ...  
Year of construction : ...  
Ex ia IIC T4 Ga  
IECEX LCIE 13.0065 X  
Ui : 30 V, Ii : 200 mA, Pi : 1 W, Li : 0, Ci : 5 nF  
Ambient temperature : - 54°C to +121°C

Approved for issue on behalf of the IECEx  
Certification Body:

Julien GAUTHIER

Position:

Certification Officer

Signature:  
(for printed version)

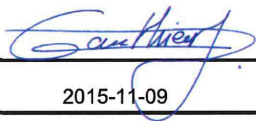
  
\_\_\_\_\_  
2015-11-09

Date:

1. This certificate and schedule may only be reproduced in full.
2. This certificate is not transferable and remains the property of the issuing body.
3. The Status and authenticity of this certificate may be verified by visiting the [Official IECEx Website](http://www.iecex.com).

Certificate issued by:

**Laboratoire Central des Industries Electriques (LCIE)**  
33 Avenue du General Leclerc  
FR-92260 Fontenay-aux-Roses  
France

Documents relative to LCIE certification activities (Certificates, QARs, ExTRs) can be registered under the references "LCI" or "LCIE".



**LCIE**



# IECEx Certificate of Conformity

Certificate No.: IECEx LCIE 13.0065X

Date of Issue: 2015-11-09

Issue No.: 1

Page 2 of 4

Manufacturer: **PCB Piezotronics**  
3425 Walden Avenue,  
Depew, New York 14043  
**United States of America**

Additional Manufacturing location  
(s):

**PCB Piezotronics of  
North Carolina Inc**  
10869 Hwy 903  
Halifax, NC 27839  
United States of America

This certificate is issued as verification that a sample(s), representative of production, was assessed and tested and found to comply with the IEC Standard list below and that the manufacturer's quality system, relating to the Ex products covered by this certificate, was assessed and found to comply with the IECEx Quality system requirements. This certificate is granted subject to the conditions as set out in IECEx Scheme Rules, IECEx 02 and Operational Documents as amended.

#### STANDARDS:

The electrical apparatus and any acceptable variations to it specified in the schedule of this certificate and the identified documents, was found to comply with the following standards:

**IEC 60079-0 : 2011** Explosive atmospheres - Part 0: General requirements  
Edition: 6.0

**IEC 60079-11 : 2011** Explosive atmospheres - Part 11: Equipment protection by intrinsic safety "i"  
Edition: 6.0

*This Certificate **does not** indicate compliance with electrical safety and performance requirements other than those expressly included in the Standards listed above.*

#### TEST & ASSESSMENT REPORTS:

*A sample(s) of the equipment listed has successfully met the examination and test requirements as recorded in*

Test Report:  
FR/LCIE/ExTR13.0060/00

FR/LCIE/ExTR15.0119/00

Quality Assessment Report:

NL/DEK/QAR14.0004/01



# IECEx Certificate of Conformity

Certificate No.: IECEx LCIE 13.0065X

Date of Issue: 2015-11-09

Issue No.: 1

Page 3 of 4

## Schedule

### EQUIPMENT:

*Equipment and systems covered by this certificate are as follows:*

The pressure sensors 1xxAyyy, 1xxByyy, 1xxMyyy are comprised of a piezo-crystal assembly, a charge amplifier and a connector. The assembly is mounted inside a metallic enclosure.

All models use one metal enclosure to house both the piezo-crystal and the charge amplifier. The models differ from each other only in minor amplifier circuitry component values and in minor mechanical mounting variations.

The "xx" in the model number denotes frequency response.

The "yyy" in the model number denotes minor mechanical mounting variations, variations in pressure range and variations in low frequency response.

### CONDITIONS OF CERTIFICATION: YES as shown below:

Ambient temperature : - 54°C to +121°C

The apparatus must only be connected to a certified associated intrinsically safe equipment. This combination must be compatible as regards intrinsic safety rules ( $U_i$  : 30 V,  $I_i$  : 200 mA,  $P_i$  : 1 W,  $L_i$  : 0,  $C_i$  : 5 nF).

Concerning the use of the Pressure Sensor, see instruction manual of the manufacturer.



# IECEx Certificate of Conformity

Certificate No.: IECEx LCIE 13.0065X

Date of Issue: 2015-11-09

Issue No.: 1

Page 4 of 4

## DETAILS OF CERTIFICATE CHANGES (for issues 1 and above):

**Issue 01** : Modification of QAR



# IECEX Certificate of Conformity

## INTERNATIONAL ELECTROTECHNICAL COMMISSION IEC Certification Scheme for Explosive Atmospheres

for rules and details of the IECEx Scheme visit [www.iecex.com](http://www.iecex.com)

Certificate No.: **IECEX LCIE 13.0065X** issue No.: **0** Certificate history:

Status: **Current**

Date of Issue: **2013-11-29** Page 1 of 3

Applicant: **PCB Piezotronics Inc**  
3425 Walden Avenue,  
Depew, New York 14043  
**United States of America**

Electrical Apparatus: **Pressure Sensor**  
*Optional accessory:*

Type of Protection: **Intrinsic safety "i"**

Marking: **PCB**  
Address : ...  
Type : 1xxAyyy, 1xxByyy or 1xxMyyy  
Serial number : ...  
Year of construction : ...  
Ex ia IIC T4 Ga  
IECEX LCIE 13.0065 X  
Ui : 30 V, Ii : 200 mA, Pi : 1 W, Li : 0, Ci : 5 nF  
Ambient temperature : - 54°C to +121°C

Approved for issue on behalf of the IECEx Certification Body: **Julien GAUTHIER**

Position: **Certification Officer**

Signature:  
(for printed version)

  
\_\_\_\_\_  
2013-11-29  
\_\_\_\_\_

Date:

1. This certificate and schedule may only be reproduced in full.
2. This certificate is not transferable and remains the property of the issuing body.
3. The Status and authenticity of this certificate may be verified by visiting the Official IECEx Website.

Certificate issued by:  
**Laboratoire Central des Industries Electriques (LCIE)**  
33 Avenue du General Leclerc  
FR-92260 Fontenay-aux-Roses  
France

Documents relative to LCIE certification activities (Certificates, QARs, EXTRs) can be registered under the references "LCI" or "LCIE".





# IECEX Certificate of Conformity

Certificate No.: IECEX LCIE 13.0065X

Date of Issue: 2013-11-29

Issue No.: 0

Page 2 of 3

Manufacturer: **PCB Piezotronics Inc**  
3425 Walden Avenue,  
Depew, New York 14043  
**United States of America**

Additional Manufacturing location  
(s):

**PCB Piezotronics of  
North Carolina Inc**  
10869 Hwy 903  
Halifax, NC 27839  
United States of America

This certificate is issued as verification that a sample(s), representative of production, was assessed and tested and found to comply with the IEC Standard list below and that the manufacturer's quality system, relating to the Ex products covered by this certificate, was assessed and found to comply with the IECEX Quality system requirements. This certificate is granted subject to the conditions as set out in IECEX Scheme Rules, IECEX 02 and Operational Documents as amended.

#### STANDARDS:

The electrical apparatus and any acceptable variations to it specified in the schedule of this certificate and the identified documents, was found to comply with the following standards:

**IEC 60079-0 : 2011** Explosive atmospheres - Part 0: General requirements  
Edition: 6.0

**IEC 60079-11 : 2011** Explosive atmospheres - Part 11: Equipment protection by intrinsic safety "i"  
Edition: 6.0

*This Certificate **does not** indicate compliance with electrical safety and performance requirements other than those expressly included in the Standards listed above.*

#### TEST & ASSESSMENT REPORTS:

*A sample(s) of the equipment listed has successfully met the examination and test requirements as recorded in*

#### Test Report:

FR/LCIE/ExTR13.0060/00

#### Quality Assessment Report:

CA/CSA/QAR09.0018/02



# IECEx Certificate of Conformity

Certificate No.: IECEx LCIE 13.0065X

Date of Issue: 2013-11-29

Issue No.: 0

Page 3 of 3

## Schedule

### EQUIPMENT:

*Equipment and systems covered by this certificate are as follows:*

The pressure sensors 1xAyyy, 1xByyy, 1xMyyy are comprised of a piezo-crystal assembly, a charge amplifier and a connector. The assembly is mounted inside a metallic enclosure.

All models use one metal enclosure to house both the piezo-crystal and the charge amplifier. The models differ from each other only in minor amplifier circuitry component values and in minor mechanical mounting variations.

The "xx" in the model number denotes frequency response.

The "yyy" in the model number denotes minor mechanical mounting variations, variations in pressure range and variations in low frequency response.

### CONDITIONS OF CERTIFICATION: YES as shown below:

Ambient temperature : - 54°C to +121°C

The apparatus must only be connected to a certified associated intrinsically safe equipment. This combination must be compatible as regards intrinsic safety rules ( $U_i$  : 30 V,  $I_i$  : 200 mA,  $P_i$  : 1 W,  $L_i$  : 0,  $C_i$  : 5 nF).

Concerning the use of the Pressure Sensor, see instruction manual of the manufacturer.