

72427

PCB Piezotronics Inc. claims proprietary rights in the information disclosed hereon. Neither it nor any reproduction thereof will be disclosed to others without the written consent of PCB Piezotronics Inc.

REVISIONS		
REV	DESCRIPTION	DIN
NR	RELEASED TO DRAFTING	50050

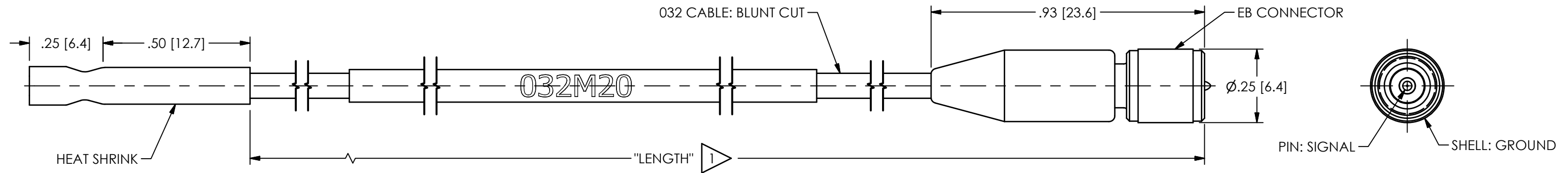

PIN OUT		
032 CONNECTOR	EB	FUNCTION
WHITE	PIN	SIGNAL
BLACK	SHELL	GROUND
SHIELD	SHELL	GROUND

SCHEMATIC DIAGRAM

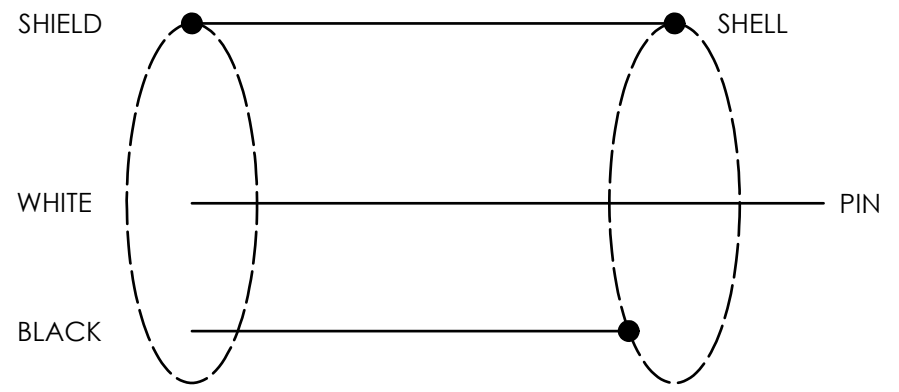

- 3.) COIL THE CABLE DEPENDING ON LENGTH TO FIT PACKAGING
- 2.) OUTSIDE PROCESS
 - A. VACUUM CLEAN PER GSA 07 02220 GRADE 2
 - B. RGA TESTING AND REPORT
 - C. CLEAN ROOM BAGGING PER:
 - I. GSA 06 0011 LABELING SPECIFICATION
 - II. GSA 05 0214 PACKAGING

1) LENGTH WILL VARY IN FEET OR METERS DEPENDING ON THE MODEL

CABLE LENGTH TOLERANCE	
LENGTH	TOLERANCE
1"-11"	+1"/-0"
1'-4'	+4"/-0"
5'-99'	+6"/-0"
99'+	+1"/-0"

UNLESS OTHERWISE SPECIFIED TOLERANCES ARE:		DRAWN		CHECKED		ENGINEER	
DIMENSIONS IN INCHES	DIMENSIONS IN MILLIMETERS [IN BRACKETS]	JES	10/15/19	JDM	10/15/19	GP	10/15/19
DECIMALS XX ±.03 XXX ±.010	DECIMALS X ±0.8 XX ±0.25	TITLE OUTLINE DRAWING MODEL 032M20					
ANGLES ± 2 DEGREES	ANGLES ± 2 DEGREES						
FILLETS AND RADII .003 - .005	FILLETS AND RADII 0.07 - 0.13						
		CODE IDENT. NO. 52681		DWG. NO. 72427		3425 WALDEN AVE. DEPEW, NY 14043 (716) 684-0001 E-MAIL: sales@pcb.com	
		SCALE: 3X		SHEET 1 OF 1			