



Model 4115K-13A
Rotary Transformer Torque Sensor
Installation and Operating Manual

For assistance with the operation of this product, contact:

PCB Load & Torque, Inc.
Toll-free: 866-684-7107
24-hour SensorLine™: 716-684-0001
Fax: 248-888-8266
E-mail: LTInfo@pcbloadtorque.com
Web: www.pcbLoadTorque.com



Repair and Maintenance

PCB guarantees Total Customer Satisfaction through its “Lifetime Warranty Plus” on all Platinum Stock Products sold by PCB and through its limited warranties on all other PCB Stock, Standard and Special products. Due to the sophisticated nature of our sensors and associated instrumentation, **field servicing and repair is not recommended and, if attempted, will void the factory warranty.**

Beyond routine calibration and battery replacements where applicable, our products require no user maintenance. Clean electrical connectors, housings, and mounting surfaces with solutions and techniques that will not harm the material of construction. Observe caution when using liquids near devices that are not hermetically sealed. Such devices should only be wiped with a dampened cloth—never saturated or submerged.

In the event that equipment becomes damaged or ceases to operate, our Application Engineers are here to support your troubleshooting efforts 24 hours a day, 7 days a week. Call or email with model and serial number as well as a brief description of the problem.

Calibration

Routine calibration of sensors and associated instrumentation is necessary to maintain measurement accuracy. We recommend calibrating on an annual basis, after exposure to any extreme environmental influence, or prior to any critical test.

PCB Piezotronics is an ISO-9001 certified company whose calibration services are accredited by A2LA to ISO/IEC 17025, with full traceability to SI through N.I.S.T. In addition to our standard calibration services, we also offer specialized tests, including: sensitivity at elevated or cryogenic temperatures, phase response, extended high or low frequency response, extended range, leak testing, hydrostatic pressure testing, and others. For more information, contact your local PCB Piezotronics distributor, sales representative, or factory customer service representative.

Returning Equipment

If factory repair is required, our representatives will provide you with a Return Material Authorization (RMA) number, which we use to reference any information you have already provided and expedite the repair process. This number should be clearly marked on the outside of all returned package(s) and on any packing list(s) accompanying the shipment.

Contact Information

PCB Piezotronics, Inc.
3425 Walden Ave.
Depew, NY14043 USA
Toll-free: (800) 828-8840
24-hour SensorLine: (716) 684-0001
General inquiries: info@pcb.com
Repair inquiries: rma@pcb.com

For a complete list of distributors, global offices and sales representatives, visit our website, www.pcb.com.

Safety Considerations

This product is intended for use by qualified personnel who recognize shock hazards and are familiar with the precautions required to avoid injury. While our equipment is designed with user safety in mind, the protection provided by the equipment may be impaired if equipment is used in a manner not specified by this manual.

Discontinue use and contact our 24-Hour Sensorline if:

- Assistance is needed to safely operate equipment
- Damage is visible or suspected
- Equipment fails or malfunctions

For complete equipment ratings, refer to the enclosed specification sheet for your product.

Definition of Terms and Symbols

The following symbols may be used in this manual:



DANGER

Indicates an immediate hazardous situation, which, if not avoided, may result in death or serious injury.

**CAUTION**

Refers to hazards that could damage the instrument.

**NOTE**

Indicates tips, recommendations and important information. The notes simplify processes and contain additional information on particular operating steps.

The following symbols may be found on the equipment described in this manual:



This symbol on the unit indicates that high voltage may be present. Use standard safety precautions to avoid personal contact with this voltage.



This symbol on the unit indicates that the user should refer to the operating instructions located in the manual.



This symbol indicates safety, earth ground.



PCB工业监视和测量设备 - 中国RoHS2公布表

PCB Industrial Monitoring and Measuring Equipment - China RoHS 2 Disclosure Table

部件名称	有害物质					
	铅 (Pb)	汞 (Hg)	镉 (Cd)	六价铬 (Cr(VI))	多溴联苯 (PBB)	多溴二苯醚 (PBDE)
住房	0	0	0	0	0	0
PCB板	X	0	0	0	0	0
电气连接器	0	0	0	0	0	0
压电晶体	X	0	0	0	0	0
环氧	0	0	0	0	0	0
铁氟龙	0	0	0	0	0	0
电子	0	0	0	0	0	0
厚膜基板	0	0	X	0	0	0
电线	0	0	0	0	0	0
电缆	X	0	0	0	0	0
塑料	0	0	0	0	0	0
焊接	X	0	0	0	0	0
铜合金/黄铜	X	0	0	0	0	0
本表格依据 SJ/T 11364 的规定编制。						
0：表示该有害物质在该部件所有均质材料中的含量均在 GB/T 26572 规定的限量要求以下。						
X：表示该有害物质至少在该部件的某一均质材料中的含量超出 GB/T 26572 规定的限量要求。						
铅是欧洲RoHS指令2011/65/ EU附件三和附件四目前由于允许的豁免。						

CHINA RoHS COMPLIANCE

Component Name	Hazardous Substances					
	Lead (Pb)	Mercury (Hg)	Cadmium (Cd)	Chromium VI Compounds (Cr(VI))	Polybrominated Biphenyls (PBB)	Polybrominated Diphenyl Ethers (PBDE)
Housing	O	O	O	O	O	O
PCB Board	X	O	O	O	O	O
Electrical Connectors	O	O	O	O	O	O
Piezoelectric Crystals	X	O	O	O	O	O
Epoxy	O	O	O	O	O	O
Teflon	O	O	O	O	O	O
Electronics	O	O	O	O	O	O
Thick Film Substrate	O	O	X	O	O	O
Wires	O	O	O	O	O	O
Cables	X	O	O	O	O	O
Plastic	O	O	O	O	O	O
Solder	X	O	O	O	O	O
Copper Alloy/Brass	X	O	O	O	O	O

This table is prepared in accordance with the provisions of SJ/T 11364.

O: Indicates that said hazardous substance contained in all of the homogeneous materials for this part is below the limit requirement of GB/T 26572.

X: Indicates that said hazardous substance contained in at least one of the homogeneous materials for this part is above the limit requirement of GB/T 26572.

Lead is present due to allowed exemption in Annex III or Annex IV of the European RoHS Directive 2011/65/EU.

Table of Contents

<u>Section</u>	<u>Page</u>
Caution Note	1
1.0 Description	2
2.0 Axis Definition	2
3.0 Mechanical Setup	2
4.0 Electrical Interface	4
5.0 Calibration	4
6.0 Routine Maintenance	6
7.0 Troubleshooting	6
8.0 Interconnect Cables	7
9.0 Interface Connections	8
10.0 Speed Sensors	9

MANUAL NUMBER: 18227
MANUAL REVISION: B
ECN NUMBER: 25559

CAUTION!

Personal injury to the operator, as well as damage to equipment, can result if the torque sensor is operated at speeds higher than the maximum or with loads greater than the overload capacity listed on the specification sheet. The operator should be protected from rotating parts by using safety shield guards.

When in doubt about speed ratings or torque capacity, please consult our factory.

1.0 DESCRIPTION

PCB 4100 Series Rotating Transformer Shaft Torque Sensors consist of a specially designed shaft which can be placed between drive and load sources to measure the transfer of power, torque, and speed between them. The torque sensors (**Figure 1**) utilize strain gages on the shaft as the sensing means, and bearings to allow the shaft to turn independent of the housing, which usually remains stationary. Two rotating transformers, one normally mounted on each end of the shaft, allow for excitation and signal transfer between the rotating and non-rotating structures. The strain gages, intimately bonded to the shaft, are connected in a 4-arm Wheatstone Bridge circuit. Wires located on the corners of the bridge are typically connected through the rotary transformer to an MS-type connector on the outside of the housing.

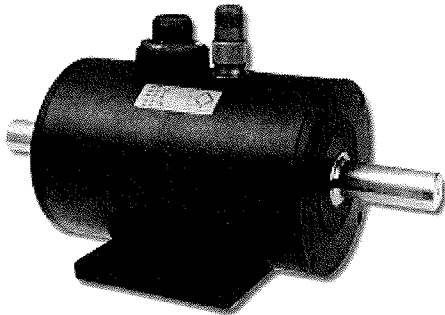

Figure 1 - 4100 Series Rotary Transformer Torque Sensor

An excitation voltage of 3 to 10 VAC RMS at 3.28 kHz is applied to pins B and C of the connector. Torque applied to the shaft causes an imbalance in the strain gage bridge on the shaft, producing an output signal at pins D and A which is linear and exactly proportional to the torque on the shaft.

2.0 AXIS DEFINITION

All PCB torque sensors comply with the Axis and Sense Definitions of NAS-938 (National Aerospace Standard-Machine Axis and Motion) nomenclature and recommendations of the Western Regional Strain Gage committee. The

axes are defined in terms of a “right-handed” orthogonal coordinate system.

The principal axis of a transducer is normally the z-axis. The z-axis will also be the axis of radial symmetry or axis of rotation. In the event there is no clearly defined axis, the following preference system will be used: z, x, y.

Figure 2 shows the axis and sense nomenclature for PCB torque sensors. A positive (+) sign indicates torque in a direction that produces a positive (+) signal voltage and generally defines a clockwise torque. When a 4100 Series Torque Sensor is paired with a current output signal conditioner (e.g. 8120C Series), the clockwise direction corresponds to the 4-20 mA. If both clockwise and counter-clockwise directions are desired, a bipolar current output is required.

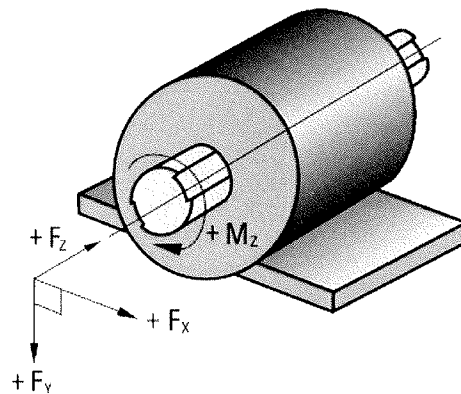

Figure 2 - Axis and Sense Nomenclature for Torque Sensors

3.0 MECHANICAL SETUP

Sensor Orientation

When installing a Model 4100 Series Torque Sensor, consideration should be given to the type of torque to be measured, drive torque or driven torque. The torque sensor should be oriented so that the end of the sensor, that the speed sensor is nearest (Drive End) is placed opposite from the desired measuring point in your system (Driven End).

Floating Mount

(Housing Unsupported or Floating)

When mounted with the housing unsupported, a

good quality “Single Flex” coupling should be used on each end of the torque shaft to connect and support it to the driving and loading devices. Each “Single Flex” coupling will compensate for angular misalignment only.

Two “Single Flex” couplings must be used, one on each end, to compensate for parallel misalignment which can occur in a “Floating Shaft” installation. Reference **Figure 3**.

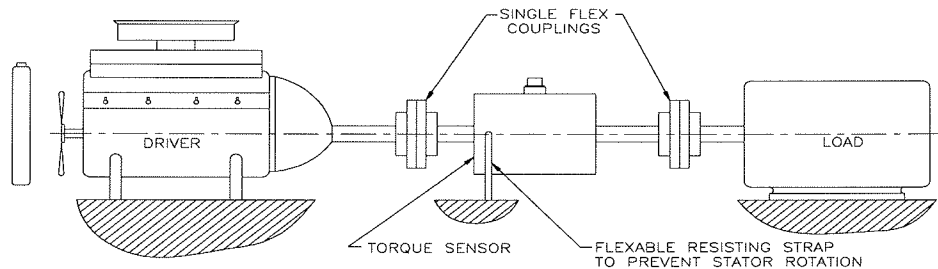

Figure 3 – “Floating” Mount

Some torque sensors in this series are provided with precision ground shaft diameters and double keyways on each end of the shaft. Install a full-length key in each keyway provided. The keys can be made from commercially available key stock and should be precision fitted. Paired keys should have identical lengths. Omission of a key, or different key lengths, can produce rotational unbalance in the shaft and should be avoided.

Shaft supported mounting requires that the housing assembly be restrained from rotating. The housing is provided with a tapped hole on the side for mounting a restraining strap. The

strap should be relatively flexible. Woven wire strap is acceptable.

Fixed Mount (Housing Supported)

When installing a torque sensor with the foot mount option, it is recommended that a “Double Flex” coupling be installed on each end of the torque shaft. Each “Double Flex” coupling will compensate for both angular and parallel misalignment that can occur in a foot mounted application. Reference **Figure 4**.

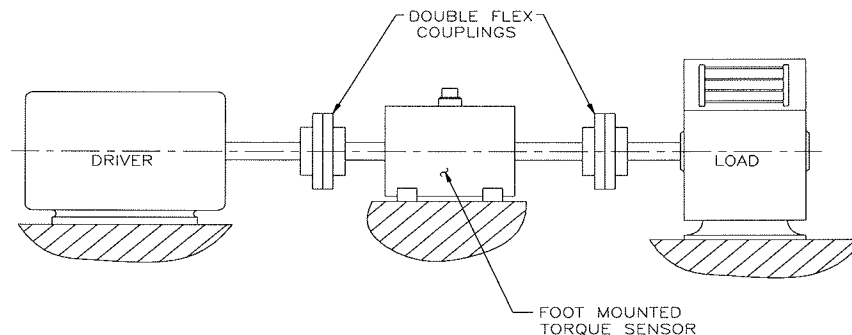

Figure 4 – Fixed Mount

After proper alignment is verified, at least two dowel pin holes should be drilled through the foot mount plate into the mounting surface below it and dowel pins installed. Installation of the dowel pins will aid in re-alignment should the torque sensor be removed and re-installed at a later date.

The same coupling precision fitting requirements outlined above also apply here. Foot mounting requires that the torque shaft be aligned as well as possible with the driving and loading devices. Ideally, the alignment should be within 0.001" per inch of shaft diameter. Consult coupling manufacturers for selection of the best couplings for your application.

Note: If you have any question about having a proper installation, please contact the factory for applications assistance.

Flange Mount (Flanged Housing)

Flange mounted torque sensors, in this series, feature precision pilot diameters on the flange ends of the housing to aid in maintaining concentricity of the mounting. Adapter flanges, used in fixturing, should utilize these pilots and be designed with the same accuracy. Careful attention should be given to possible thermal expansion producing end loading on the housing or shaft.

Additional consideration should be made, where possible, in putting thermocouples over each bearing on the housing to monitor bearing temperatures as early warning can usually prevent an impending bearing failure which can produce a catastrophic result.

4.0 ELECTRICAL INTERFACE

Torque sensors in this series typically have an MS3102E-14S-5P receptacle. A mating connector, MS3106F-14S-5S, is also supplied if a cable assembly is not purchased with the sensor. The cable used to connect the torque sensor to the signal conditioner should be a

high quality 6-wire shielded type such as Belden 8163. Pin assignments are as follows:

Pin	Function
A	-Signal
B	+Excitation
C	-Excitation
D	+Signal
E	Ground

Recommended excitation voltage is 5 volts AC (RMS) at 3.278 kHz.

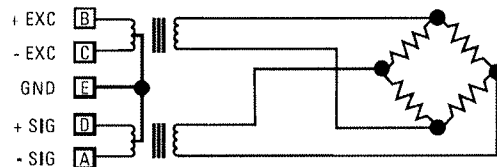

Figure 5 - 4100 Series Sensor Wiring Code

Note: See Page 7 for correct wire and shield connections.

5.0 CALIBRATION

Factory Calibration

Refer to PCB Document #21354

Field Calibration

To maintain high transducer accuracy, the calibration should be rechecked periodically with weights and lever arm. The purpose is not to exactly reproduce the factory calibration, but to look for long term changes in output. If the same lever arm and weights are always used, then precision weights are not required. Just be sure to use your non-precision weights in the same order every time.

Operational Calibration

Once installed in the users mechanical system, the torque sensor needs to be connected through the proper cable to the signal conditioner being used. When this is done and the signal conditioner is connected to the power source

and turned on and stabilized (90 minutes is satisfactory), operational calibration can proceed. One end of the torque sensor must be kept disconnected so that “locked-in” torque is not applied to the sensor, which would affect any attempt at system calibration.

Every torque sensor, no matter how exactly made, has a different strain gage bridge resistance and a different full-scale output. During final calibration at the factory, PCB technicians determine a “Calibration Number” for the torque sensor and place a precision resistor internally in the Model 8113-105A Torque Calibration Module, which is supplied with the torque sensor. This resistor circuit produces an output from the equivalent bridge in the 8113-105A, which is exactly the same as the output for a given torque from the torque sensor. This value is taken and recorded for both directions of torque.

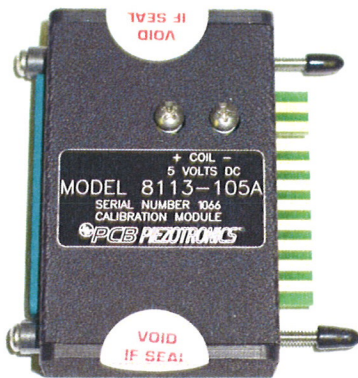

Figure 6 - Model 8113-105A Shunt Calibration Module

Place the Model 8113-105A between the cable connector and a PCB Model 8120-400A/410A. For purposes of this discussion, the PCB Model 8120-410A is the instrument of reference.

Provide a switched 5-volt DC across the screw terminals on the Model 8113-105A. +CAL is implemented by energizing the relay on the Model 8113-105A and simultaneously

depressing the +CAL button on the Model 8120-410A. -CAL is accomplished by simultaneously energizing the relay and depressing the -CAL button on the Model 8120-410A.

Preparation for Calibration

Make sure all locked-in torque is removed from the torque sensor by freeing one end of the shaft. Touch the torque sensor housing. If the instrument reading changes this means that the torque sensor housing is not properly grounded. Please provide a proper ground between the housing and a good water pipe ground.

Calibration:

- 1) De-energize the 8113-105A relay and zero the 8120 instrument.
- 2) Energize the relay and record the reading
- 3) Engage + CAL on the 8120-410A and record the reading.
- 4) Subtract reading 2 from reading 3 (be careful of sign).
- 5) Adjust span on the instrument such that the value from 4 matches the + value on the calibration data sheet.
- 6) Release + CAL and record the reading. If the reading is different from that of 2, repeat steps 2 through 6.
- 7) Engage - CAL on the instrument and record the reading.
- 8) Subtract reading 6 from 7 (be careful of sign).
- 9) Adjust symmetry on the instrument such that the value from 8 matches the - CAL value on the calibration data sheet.
- 10) Release - CAL and record the reading. If the reading is different from that of 6, repeat steps 2 through 9.
- 11) Switch the 8113-105A to “RUN” and zero the instrument.
- 12) Reassemble the coupling on the sensor. The torque measuring system is calibrated now and is ready to run.

Notes on Shunt Calibration**(Added notes for the first time user.)**

Refer to item numbers above for the items listed below.

- a. If the instrument has a NULL button and ADJUSTMENT screw it should be used in conjunction with the ZERO adjustment at this time only.
- b. This reading is a ZERO reference. The Torque Sensor zero unbalance is the difference between reading 1 and 2. This difference can be used as an indication of Torque Sensor "health". A zero unbalance of 5% F.S. or greater could indicate an overloaded or fatigued shaft.
- c. If the instrument does not have a CAL function, +CAL can be simulated by connecting the supplied shunt cal resistor between +SIG and +EXC.

Example #1

+CAL= 7250

ZERO = 32

SPAN VALUE = 7218

Example #2

+CAL = 7250

ZERO = -32

SPAN VALUE = 7282

- d. The first time the Torque Sensor is connected to the instrument, the phase adjustment of the instrument should be done. To adjust phase, simply keep +CAL engaged and rotate the instrument phase control pot until a maximum reading is achieved.
- e. No further note.
- f. If the instrument does not have a CAL function, -CAL can be simulated by connecting the supplied shunt cal resistor between +SIG and -EXC.

Example #1

+CAL= -7250

ZERO = 32

SPAN VALUE = -7282

Example #2

+CAL = -7250

ZERO = -32

SPAN VALUE = -7218

6.0 ROUTINE MAINTENANCE

Field maintenance is not required. All service maintenance on the Torque Sensor is done at the factory.

7.0 TROUBLESHOOTING

- ✓ Check all connections to the torque sensor and readout instrument.
- ✓ Check the interconnect cable for proper termination and possible damage.
- ✓ Verify the excitation and output resistances of the torque sensor match the calibration sheet. Do not apply more than our recommended voltage to the torque sensor circuit.
- ✓ Verify that the bearings are running at normal temperatures. See Mechanical Setup on Page 2.

8.0 INTERCONNECT CABLES

The length of the interconnect cable between the 4100 Series Torque Sensor and the 8113-105A Reference Module and 8120-400 Series Readout Instrument should not exceed 100 feet. If longer lengths are required, please contact the factory.

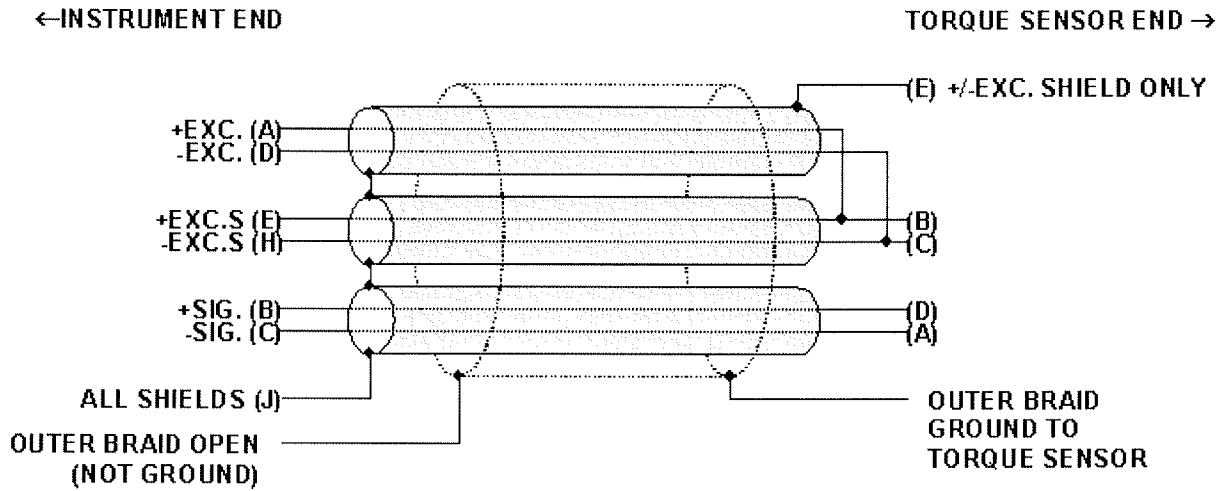

Figure 7 - Model 8310-07 Series Cable Assembly

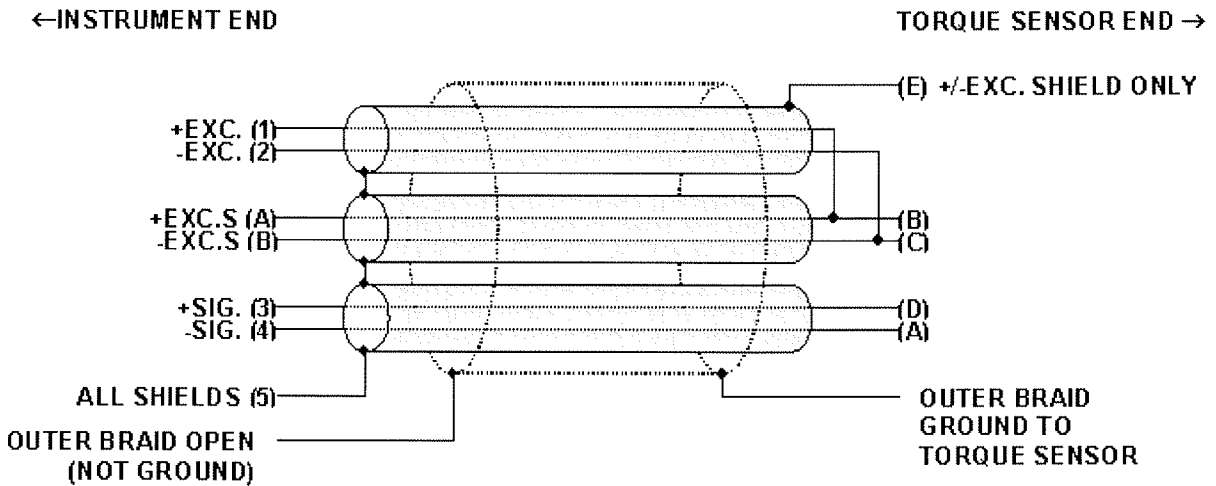

Figure 8 - Model 8310-06 Series Cable Assembly

9.0 INTERFACE CONNECTIONS

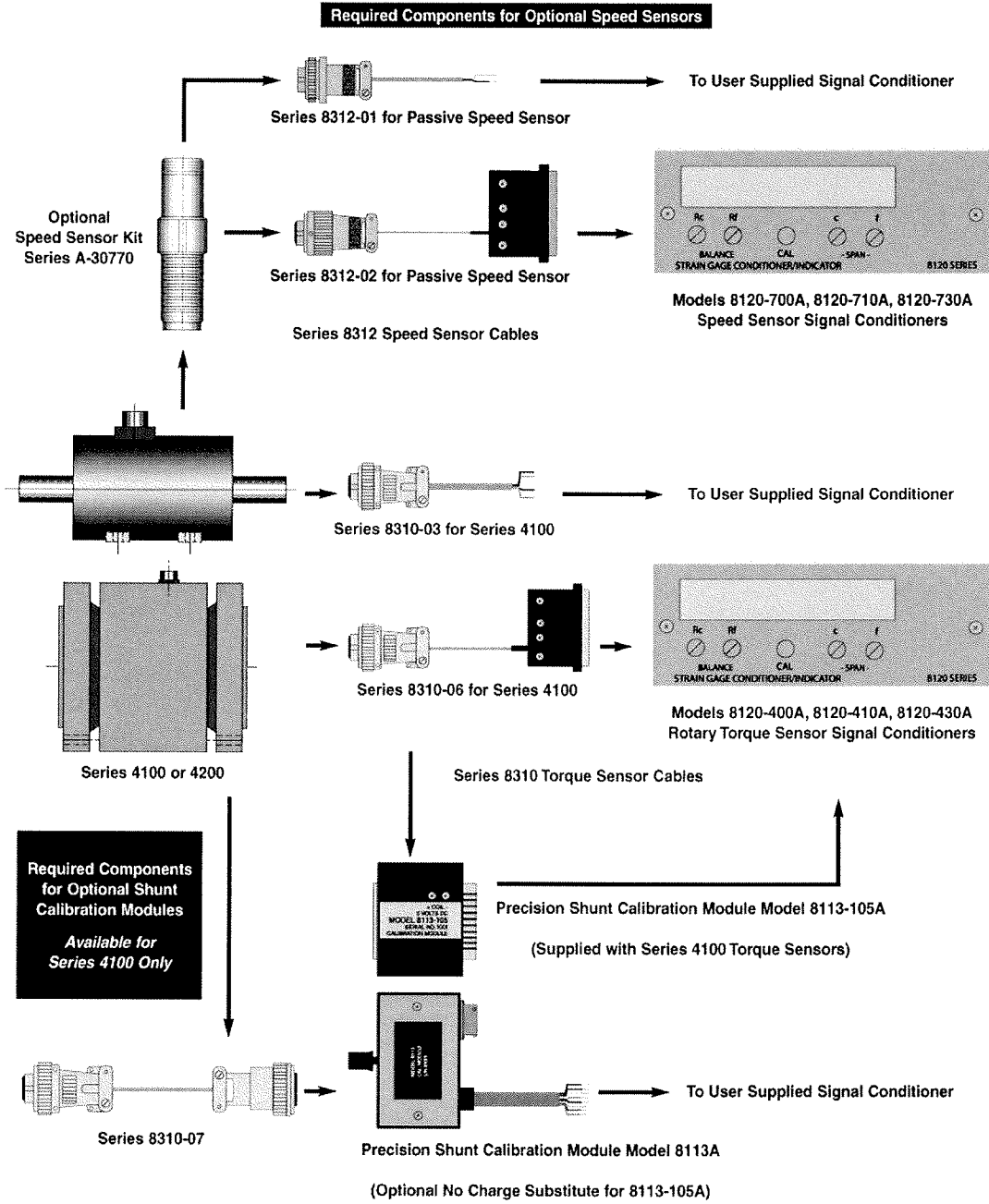

Figure 9 - Interface Connections

10.0 SPEED SENSORS

Speed sensors may be used with rotary torque sensors to provide a measurement of rotational speed. Horsepower can then be calculated using the speed and torque measurements by the following relationship:

$$\text{H.P.} = \frac{\text{Torque (in-lbs)} \times \text{R.P.M.}}{63025}$$

Two types of speed sensors are available for use with PCB rotary torque sensors: Passive Magnetic and Active Magnetic.

Passive Magnetic Speed Sensor

These sensors are self-powered units with an AC voltage output that varies in amplitude as the speed of the torque sensor changes. When used with PCB torque sensors, this unit will provide a sine wave output signal (**Figure 10**). Twisted pair shielded cable is recommended. Minimum operation speed is 200 RPM.

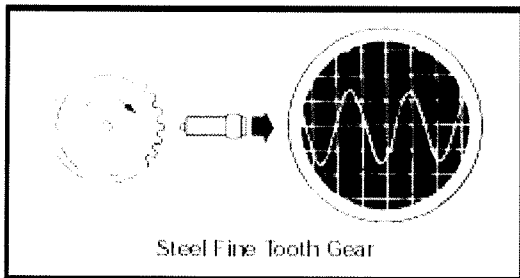

Figure 10 - Speed Sensor Output Signal

Active Magnetic Speed Sensor

This Hall Effect device installs into a port provided on the torque sensor. The output of a speed sensor switches in the presence of ferromagnetic material such as steel gear teeth. Output amplitude and waveform are affected by gear speed and tooth shape.

Speed sensor gears are usually made with 60 teeth. A speed sensor used with a 60-tooth gear will have an output of 100 Hz for a shaft speed

of 100 RPM.

Installation

Most standard PCB torque sensors are furnished with a 60-tooth integral counter gear with a 5/8-18 threaded port in the top side of the housing.

To install the speed sensor:

- 1) First remove the shipping plug and o-ring from the housing.
- 2) Ensure the sensor is not rotating. Gently thread the speed sensor into the housing until it touches the integral counter gear.
- 3) Back the speed sensor out ¼ turn, noting the position of the marking on the speed sensor.*
- 4) Turn the speed sensor clockwise or counter-clockwise which ever is closer, so that the flat is perpendicular to the torque sensor housing. Lock it in place with the two jam nuts provided.

* Proper orientation of the speed sensor tip, relative to the gear movement, is required. Reference the speed gear specification sheet for orientation information

	<u>ENGLISH</u>	<u>SI</u>	
Performance			
Measurement Range(Full Scale Capacity)	10,000 in-lb	1130 Nm	[1]
Sensitivity(± 15 %)(output at rated capacity)	2.5 mV/V	2.5 mV/V	[1][3]
Non-Linearity	≤ 0.05 % FS	≤ 0.05 % FS	[3]
Hysteresis	≤ 0.05 % FS	≤ 0.05 % FS	[3]
Non-Repeatability	≤ 0.03 % FS	≤ 0.03 % FS	[3]
Environmental			
Overload Limit	15,000 in-lb	1700 Nm	
Temperature Range(Operating)	-65 to 225 °F	-54 to 107 °C	
Temperature Range(Compensated)	+70 to +170 °F	+21 to 77 °C	
Temperature Effect on Output(Maximum)	± 0.002 %Reading/°F	± 0.0036 %Reading/°C	[4]
Temperature Effect on Zero Balance(Maximum)	± 0.002 %FS/°F	± 0.0036 %FS/°C	[4][3]
Electrical			
Bridge Resistance	350 Ohm	350 Ohm	[1]
Excitation Frequency	3.28 kHz	3.28 kHz	
Excitation Voltage	2 to 10 VAC rms	2 to 10 VAC rms	[2]
Insulation Resistance	>5,000,000 kohm	>5,000,000 kohm	
Zero Balance	≤ 2 % FS	≤ 2 % FS	[3]
Bridge Current(at 5 VAC)	50 mA	50 mA	
Physical			
Size (Shaft Length x Housing Length x Housing Height)	9.56 in x 8.25 in x 6.00 in	242.82 mm x 209.55 mm x 152.40 mm	
Weight	47 lb	21.3 kg	
Mounting	Flange w/ Splined Shaft	Flange w/ Splined Shaft	[5]
Sensing Element	Strain Gage	Strain Gage	
Housing Material	Black Oxided Steel	Black Oxided Steel	
Shaft Material	Steel	Steel	
Electrical Connector	MS3102A-14S-5P	MS3102A-14S-5P	
Torsional Stiffness	500,000 in-lb/radian	56,500 N-m/radian	
Rotating Inertia	0.0062 in-lb sec ²	0.0007 N-m sec ²	
Maximum Speed	15,000 RPM	15,000 RPM	

OPTIONAL VERSIONS

Optional versions have identical specifications and accessories as listed for the standard model except where noted below. More than one option may be used.

NOTES:

[1]Nominal.
 [2]Recommended 10 VAC RMS.
 [3]FS - Full Scale.
 [4]Over compensated operating temperature range.
 [5]Mounting per AND10262 and AND20002.
 [6]See PCB Declaration of Conformance PS062 for details.

SUPPLIED ACCESSORIES:

Model 180-019A 5-socket mating connector for Series 3100, 4100, 4200 torque sensors
 Model 8113-105A Relay activated precision shunt calibration module

Entered: AP	Engineer: PE	Sales: KWW	Approved: JSD	Spec Number:
Date: 2/13/2015	Date: 2/13/2015	Date: 2/13/2015	Date: 2/13/2015	18493



PCB Load & Torque, Inc.
24350 Indoplex Circle
Farmington Hills, MI 48335
UNITED STATES
Phone: 866-684-7107
Fax: 716-684-0987
E-Mail: linfo@pcbloadtorque.com
Web site:
http://www.pcbloadtorque.com



[6]
 All specifications are at room temperature unless otherwise specified.
 In the interest of constant product improvement, we reserve the right to change specifications without notice.

PCB Load & Torque (A Division of PCB Piezotronics, Inc.) claims proprietary rights in the information disclosed hereon. Neither it nor any reproduction thereof will be disclosed to others without the written consent of PCB Load and Torque.

22675

REVISIONS		
REV	DESCRIPTION	ECO
A	ADDED VIBRATION MONITORING HOLES - 06.02.22, PTE	45389

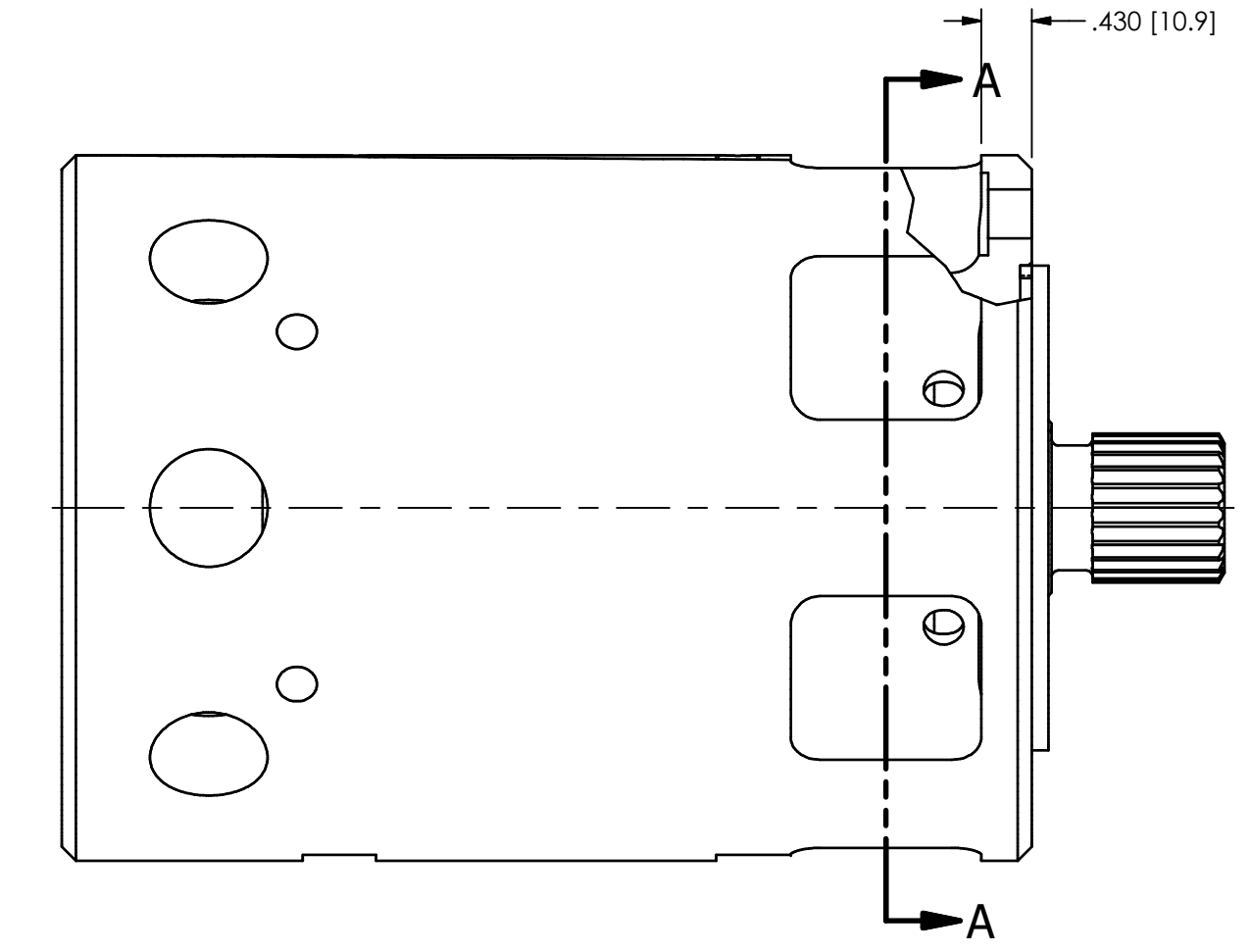
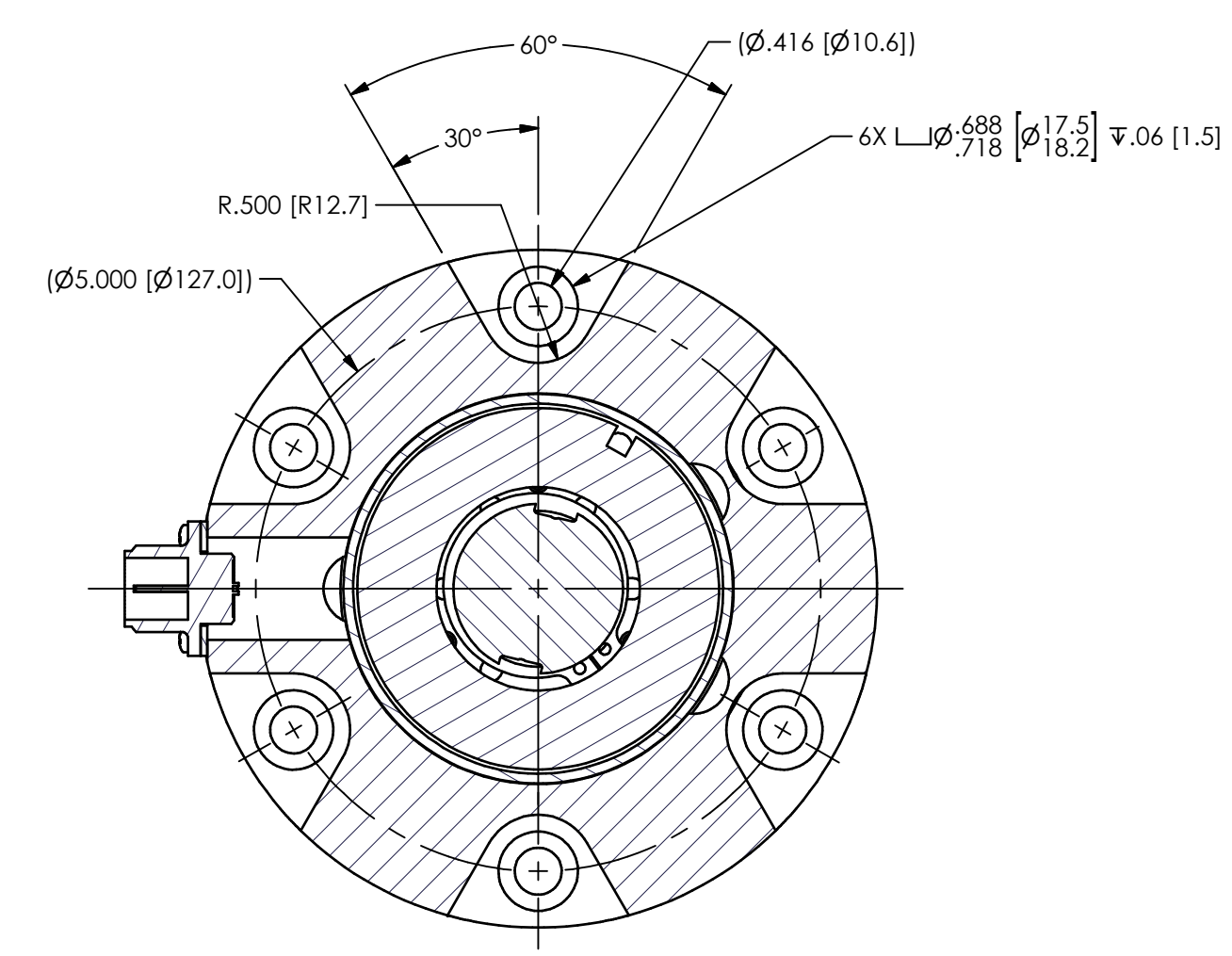
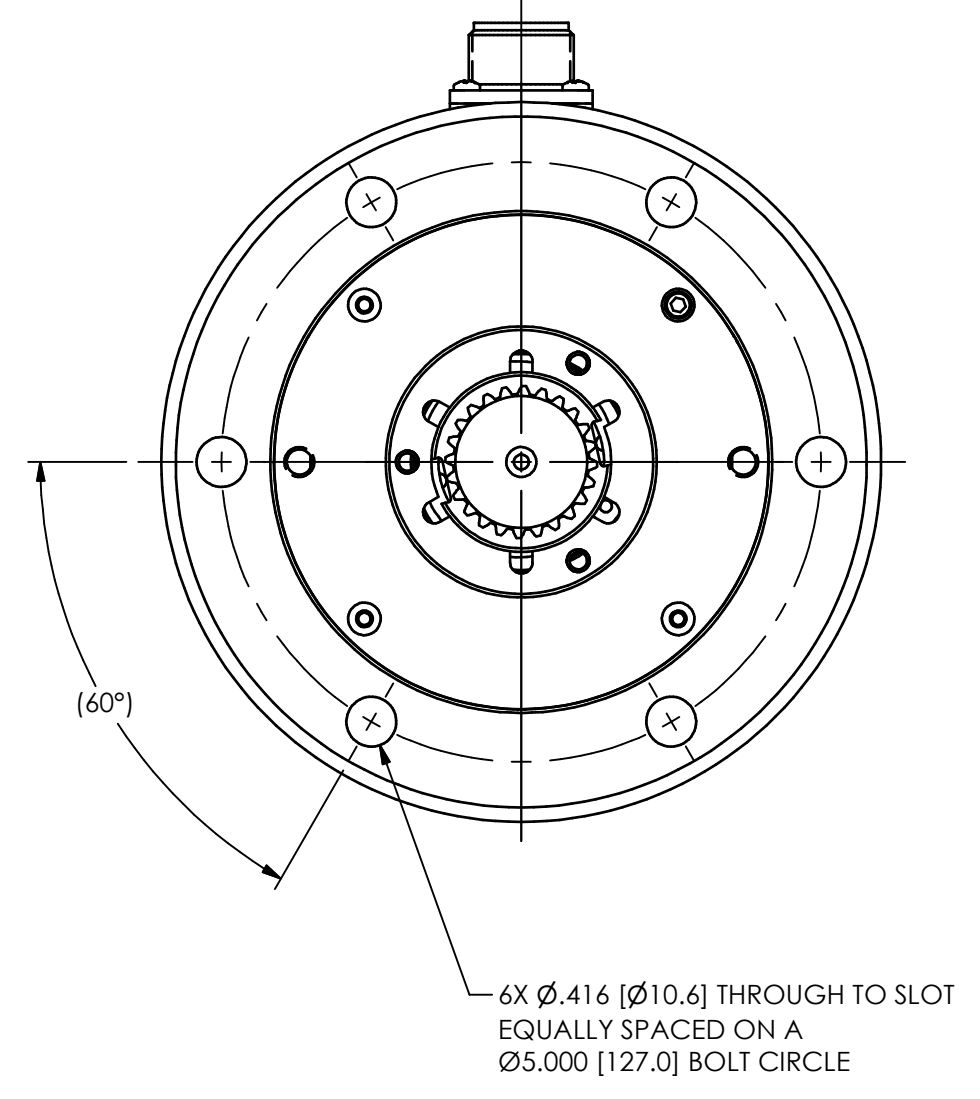
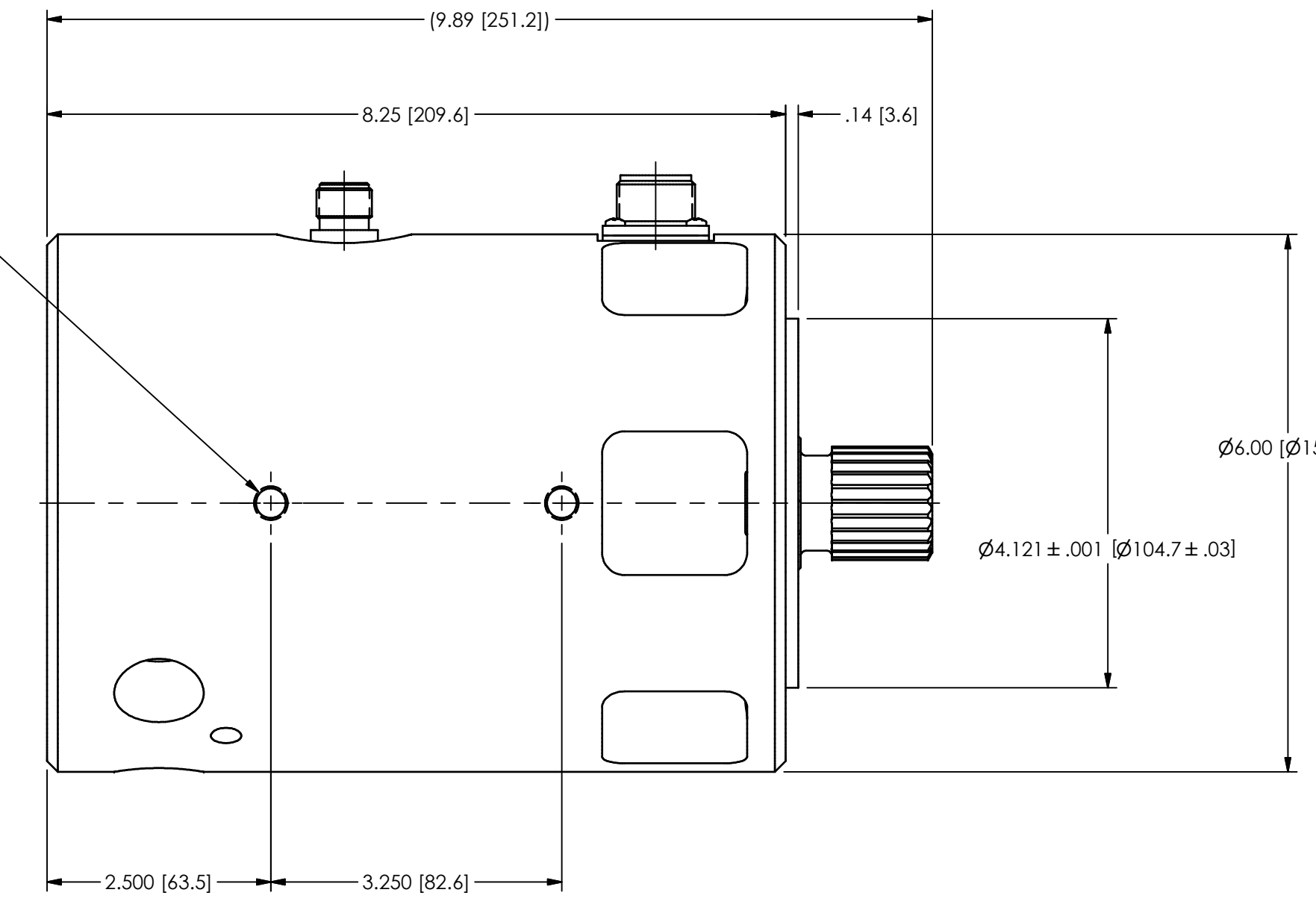
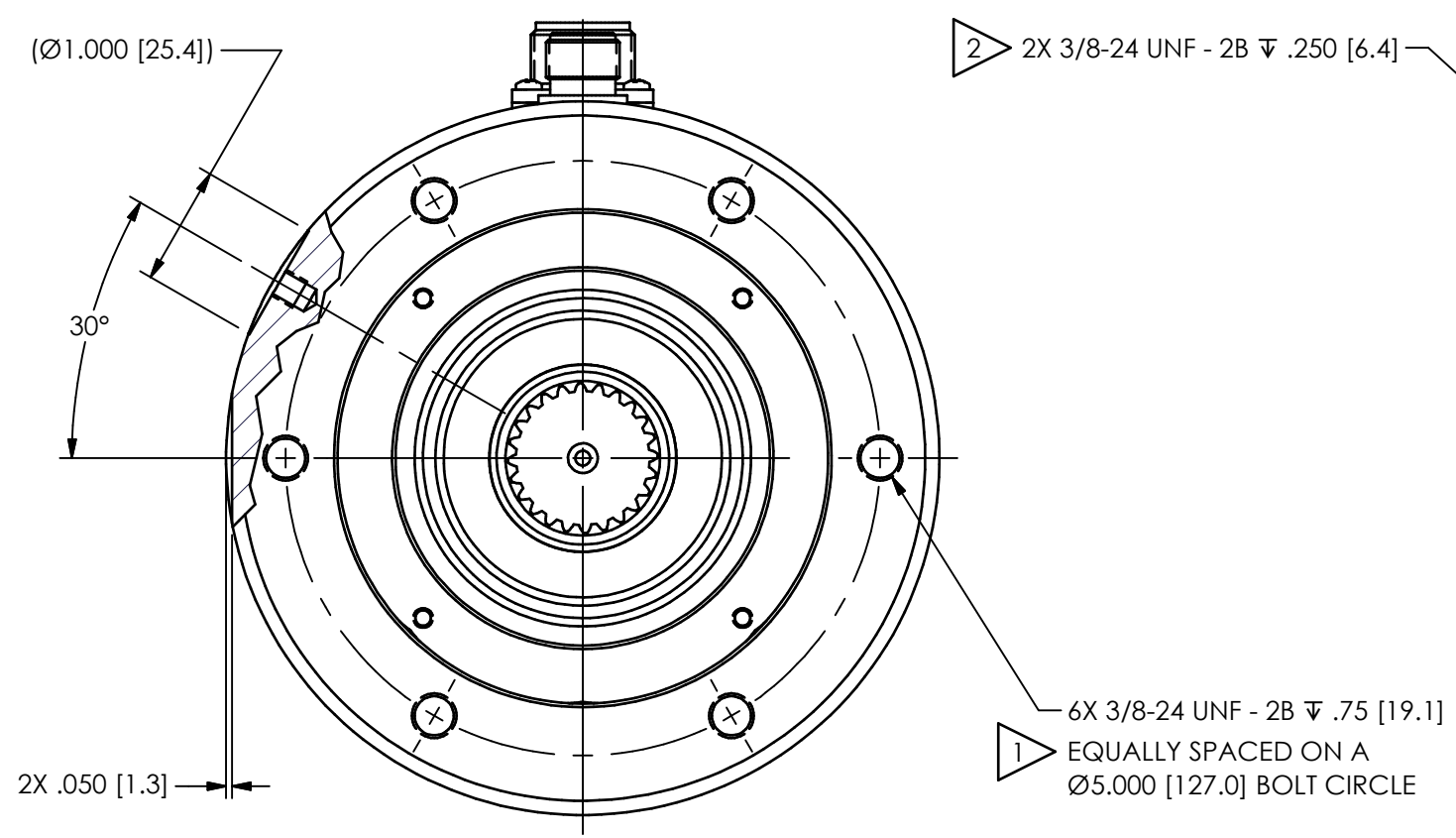
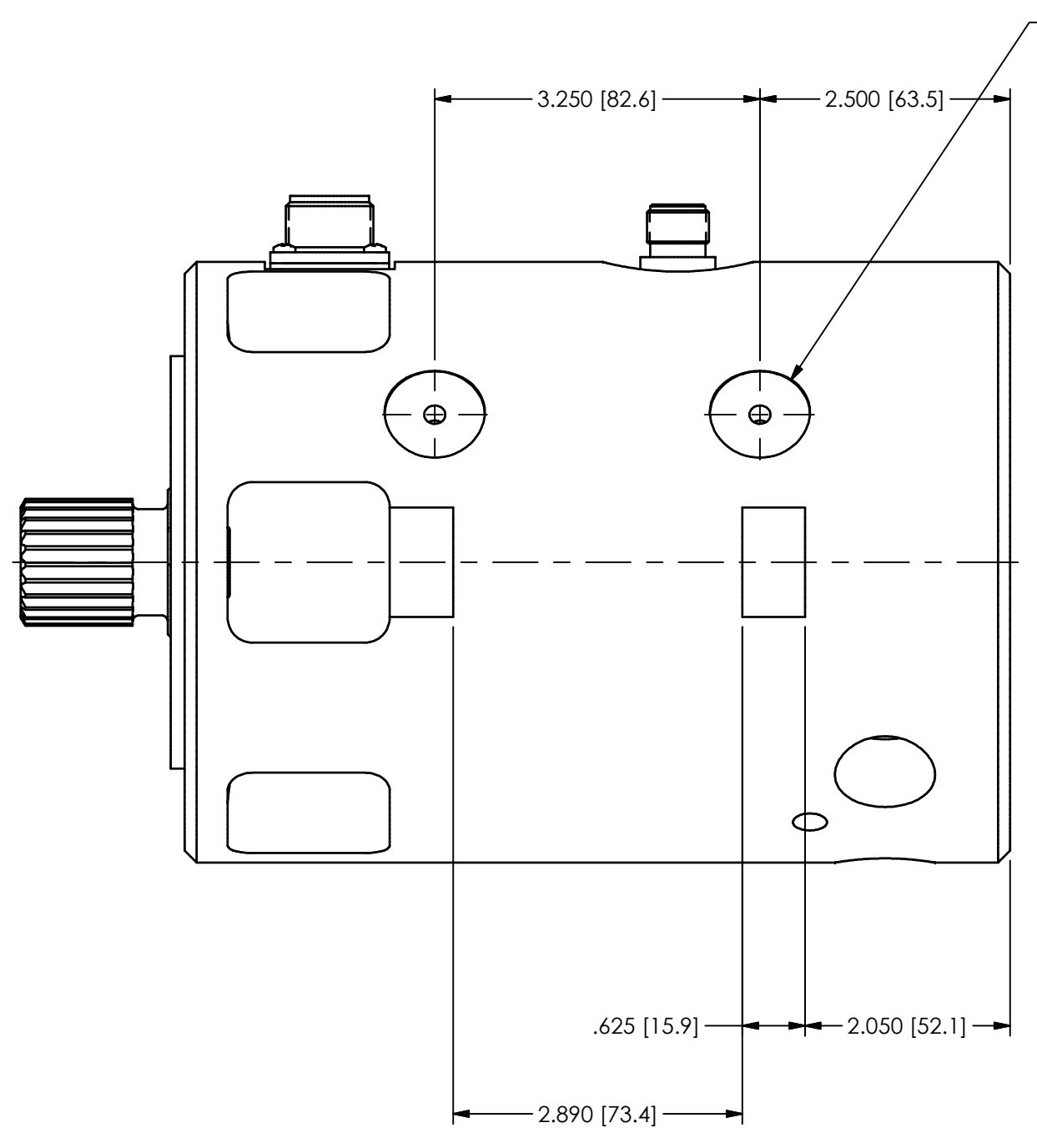
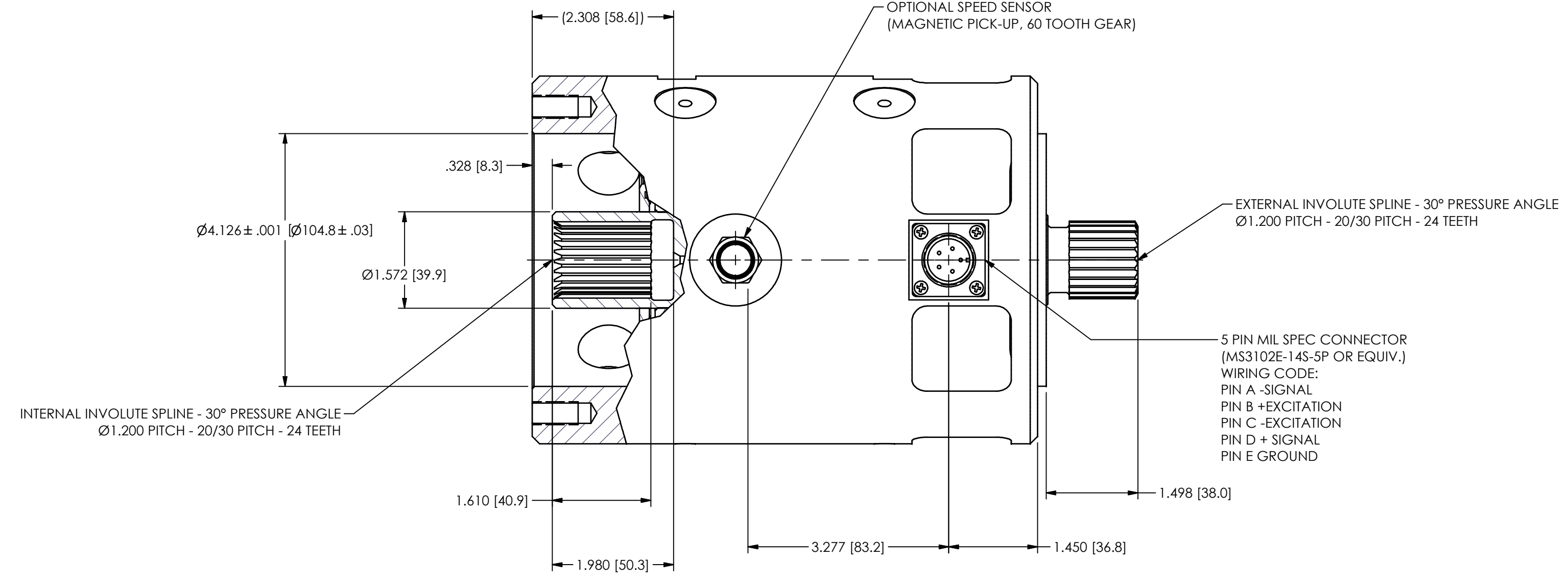
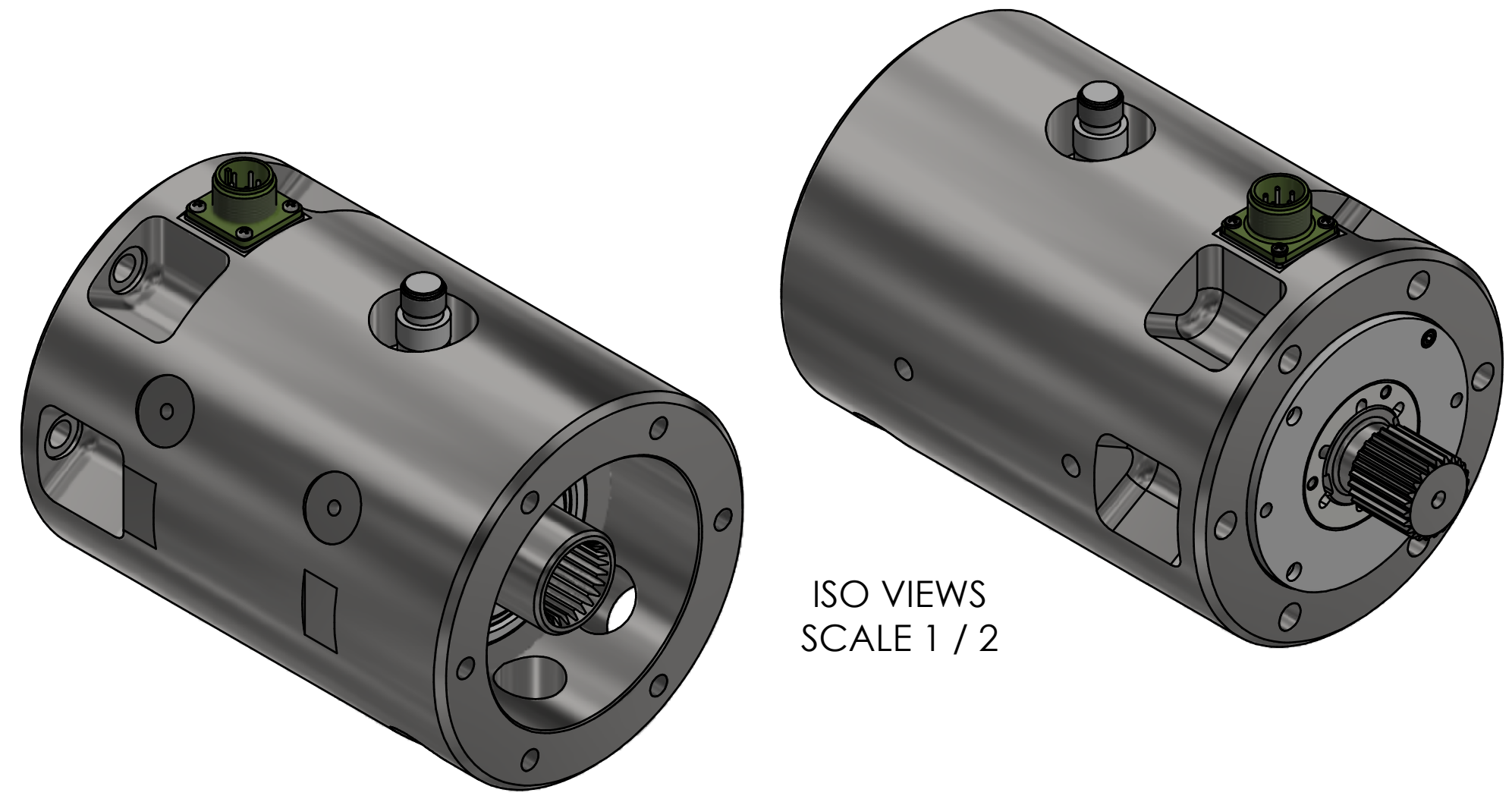

- NOTES:
- 1 3/8-24 TAPPED HOLES (6) PROVIDED FOR OPTIONAL STUDS
 - 2 3/8-24 TAPPED HOLES (2) PROVIDED FOR OPTIONAL THERMOCOUPLES FOR FOR BEARING TEMPERATURE MONITORING
 - 3 1/4-28 TAPPED HOLES (2) PROVIDED FOR OPTIONAL ACCELEROMETERS FOR VIBRATION MONITORING

UNLESS OTHERWISE SPECIFIED TOLERANCES ARE:		DRAWN			CHECKED			ENGINEER			PCB LOAD & TORQUE A PCB GROUP COMPANY
DIMENSIONS IN INCHES		PTE			JAM			PTE			
DECIMALS	XX ±.01 XXX ±.005	TITLE			DATE			DATE			DWG. NO. 22675
ANGLES	± .5 DEGREES	OUTLINE DRAWING MODEL 4115K SERIES ROTARY TRANSFORMER			5/27/22			5/27/22			
FILES AND RADI	Ø15 MAX	FILLES AND RADI			0.38 MAX			SCALE: 5 / 8			SHEET 1 OF 1