



Model 261A03
3-Component ICP® Force Sensor
Installation and Operating Manual

**For assistance with the operation of this product,
contact PCB Piezotronics, Inc.**

Toll-free: 800-828-8840
24-hour SensorLine: 716-684-0001
Fax: 716-684-0987
E-mail: info@pcb.com
Web: www.pcb.com



Repair and Maintenance

PCB guarantees Total Customer Satisfaction through its “Lifetime Warranty Plus” on all Platinum Stock Products sold by PCB and through its limited warranties on all other PCB Stock, Standard and Special products. Due to the sophisticated nature of our sensors and associated instrumentation, **field servicing and repair is not recommended and, if attempted, will void the factory warranty.**

Beyond routine calibration and battery replacements where applicable, our products require no user maintenance. Clean electrical connectors, housings, and mounting surfaces with solutions and techniques that will not harm the material of construction. Observe caution when using liquids near devices that are not hermetically sealed. Such devices should only be wiped with a dampened cloth—never saturated or submerged.

In the event that equipment becomes damaged or ceases to operate, our Application Engineers are here to support your troubleshooting efforts 24 hours a day, 7 days a week. Call or email with model and serial number as well as a brief description of the problem.

Calibration

Routine calibration of sensors and associated instrumentation is necessary to maintain measurement accuracy. We recommend calibrating on an annual basis, after exposure to any extreme environmental influence, or prior to any critical test.

PCB Piezotronics is an ISO-9001 certified company whose calibration services are accredited by A2LA to ISO/IEC 17025, with full traceability to SI through N.I.S.T. In addition to our standard calibration services, we also offer specialized tests, including: sensitivity at elevated or cryogenic temperatures, phase response, extended high or low frequency response, extended range, leak testing, hydrostatic pressure testing, and others. For more information, contact your local PCB Piezotronics distributor, sales representative, or factory customer service representative.

Returning Equipment

If factory repair is required, our representatives will provide you with a Return Material Authorization (RMA) number, which we use to reference any information you have already provided and expedite the repair process. This number should be clearly marked on the outside of all returned package(s) and on any packing list(s) accompanying the shipment.

Contact Information

PCB Piezotronics, Inc.
3425 Walden Ave.
Depew, NY14043 USA
Toll-free: (800) 828-8840
24-hour SensorLine: (716) 684-0001
General inquiries: info@pcb.com
Repair inquiries: rma@pcb.com

For a complete list of distributors, global offices and sales representatives, visit our website, www.pcb.com.

Safety Considerations

This product is intended for use by qualified personnel who recognize shock hazards and are familiar with the precautions required to avoid injury. While our equipment is designed with user safety in mind, the protection provided by the equipment may be impaired if equipment is used in a manner not specified by this manual.

Discontinue use and contact our 24-Hour Sensorline if:

- Assistance is needed to safely operate equipment
- Damage is visible or suspected
- Equipment fails or malfunctions

For complete equipment ratings, refer to the enclosed specification sheet for your product.

Definition of Terms and Symbols

The following symbols may be used in this manual:



DANGER

Indicates an immediate hazardous situation, which, if not avoided, may result in death or serious injury.

**CAUTION**

Refers to hazards that could damage the instrument.

**NOTE**

Indicates tips, recommendations and important information. The notes simplify processes and contain additional information on particular operating steps.

The following symbols may be found on the equipment described in this manual:



This symbol on the unit indicates that high voltage may be present. Use standard safety precautions to avoid personal contact with this voltage.



This symbol on the unit indicates that the user should refer to the operating instructions located in the manual.



This symbol indicates safety, earth ground.



PCB工业监视和测量设备 - 中国RoHS2公布表

PCB Industrial Monitoring and Measuring Equipment - China RoHS 2 Disclosure Table

部件名称	有害物质					
	铅 (Pb)	汞 (Hg)	镉 (Cd)	六价铬 (Cr(VI))	多溴联苯 (PBB)	多溴二苯醚 (PBDE)
住房	0	0	0	0	0	0
PCB板	X	0	0	0	0	0
电气连接器	0	0	0	0	0	0
压电晶体	X	0	0	0	0	0
环氧	0	0	0	0	0	0
铁氟龙	0	0	0	0	0	0
电子	0	0	0	0	0	0
厚膜基板	0	0	X	0	0	0
电线	0	0	0	0	0	0
电缆	X	0	0	0	0	0
塑料	0	0	0	0	0	0
焊接	X	0	0	0	0	0
铜合金/黄铜	X	0	0	0	0	0
本表格依据 SJ/T 11364 的规定编制。						
0：表示该有害物质在该部件所有均质材料中的含量均在 GB/T 26572 规定的限量要求以下。						
X：表示该有害物质至少在该部件的某一均质材料中的含量超出 GB/T 26572 规定的限量要求。						
铅是欧洲RoHS指令2011/65/ EU附件三和附件四目前由于允许的豁免。						

CHINA RoHS COMPLIANCE

Component Name	Hazardous Substances					
	Lead (Pb)	Mercury (Hg)	Cadmium (Cd)	Chromium VI Compounds (Cr(VI))	Polybrominated Biphenyls (PBB)	Polybrominated Diphenyl Ethers (PBDE)
Housing	O	O	O	O	O	O
PCB Board	X	O	O	O	O	O
Electrical Connectors	O	O	O	O	O	O
Piezoelectric Crystals	X	O	O	O	O	O
Epoxy	O	O	O	O	O	O
Teflon	O	O	O	O	O	O
Electronics	O	O	O	O	O	O
Thick Film Substrate	O	O	X	O	O	O
Wires	O	O	O	O	O	O
Cables	X	O	O	O	O	O
Plastic	O	O	O	O	O	O
Solder	X	O	O	O	O	O
Copper Alloy/Brass	X	O	O	O	O	O

This table is prepared in accordance with the provisions of SJ/T 11364.

O: Indicates that said hazardous substance contained in all of the homogeneous materials for this part is below the limit requirement of GB/T 26572.

X: Indicates that said hazardous substance contained in at least one of the homogeneous materials for this part is above the limit requirement of GB/T 26572.

Lead is present due to allowed exemption in Annex III or Annex IV of the European RoHS Directive 2011/65/EU.

Table of Contents		
<u>Section</u>		<u>Page</u>
1.0	Introduction	2
2.0	Description	2
3.0	Installation	2
4.0	Operation	3
5.0	Polarity	3
6.0	Low Frequency Monitoring	3
7.0	Discharge Time Constant	4
8.0	Calibration	4
9.0	Troubleshooting	5
10.0	Maintenance	5
<u>Figure</u>		<u>Page</u>
1	3-Component Force Link Axis Definition	2
2	ICP® 3-Component Force Link	2
3	Cable Strain Relief	3
4	Characteristic Discharge Time Constant Curve	4
5	Step Function Response	4

MANUAL NUMBER: 29015
MANUAL REVISION: NR
ECO NUMBER:

1.0 INTRODUCTION

PCB Piezotronics 3-component force link sensors are designed to simultaneously measure dynamic and quasi-static force measurements in three orthogonal directions; F_x , F_y , and F_z . (Figure 1) The sensors utilize an array of precision aligned, quartz sensing crystals stacked in a preloaded arrangement.

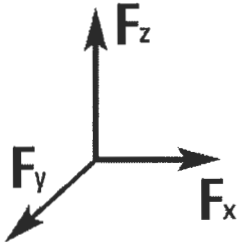

Figure 1 - 3-Component Force Link Axis Definition

2.0 DESCRIPTION

A link consists of a standard PCB 3-component force sensor, preloaded between two precision ground plates. (Figure 2) The plates are internally threaded to facilitate fixturing for both tensile and compressive force measurements. External preloads are not required with these sensors, as they are internally preloaded during manufacture.

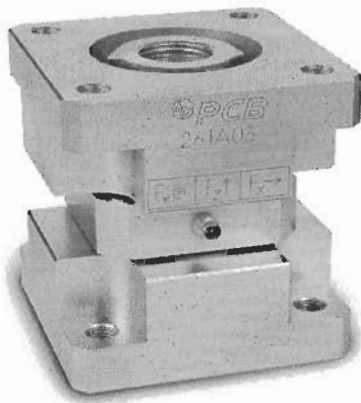

Figure 2 - ICP® 3-Component Force Link

Caution: *Loosening or tightening of the hex nuts will change the internal preload of the sensor. At this point, the sensitivity provided on the calibration certificate will no longer represent that of the sensor.*

If this should occur, refer to the service and repair document for proper information.

Measurements along the z-axis are proportional to applied compression, tension, and impact forces. Measurements along the x- and y-axis are proportional to shear forces imposed upon the sensor.

ICP® force link sensors contain built-in, microelectronic signal conditioning circuitry to provide clean, low-impedance output signals that can be transmitted over low cost cables and in adverse, industrial environments. Multi-pin connectors facilitate a single point hookup with common, multi-conductor cable.

Power to operate ICP® sensors is generally in the form of a low cost, 24-27 VDC, 2-20 mA constant current supply. PCB offers a number of AC or battery-powered, single or multi-channel power/signal conditioners, with or without gain capabilities for use with force sensors. In addition, many data acquisition systems now incorporate constant current power for directly powering ICP® sensors. Because static calibration or quasi-static short-term response lasting up to a few seconds is often required, PCB manufactures signal conditioners that provide DC coupling.

If questions arise regarding the operation or characteristics of the force sensor products as outlined in this manual, feel free to contact an experienced applications engineer from the Force/Torque Division of PCB toll-free 888-684-0004.

3.0 INSTALLATION

CAUTION!

Please read all instructions before attempting to operate this product.

Damage to built-in amplifier due to incorrect power or misapplication is NOT covered by warranty

Refer to the installation/outline drawing supplied with this manual for specific outline dimensions and installation details for your particular model. The specification is also included to provide details of the sensor's characteristic properties.

The condition of the mating surfaces can adversely affect the sensitivity of the sensor. It is essential that all surfaces be clean, rigid and perfectly flat to avoid erroneous data. A good mating surface may be obtained by lapping, turning, spot-facing, or surface grinding. Surface flatness should be held to within 0.001 (TIR) over the entire mating surface. The protective cap should remain on the connector during installation to prevent contamination or damage.

A light coating of silicon grease (DC-4 or equivalent) on the mating surface enhances the coupling between the mounting base and mounting surface and provides the best high-frequency response.

Connect one end of the interconnect cable to the sensor connector and the other end to the XDCR jack on the signal conditioner. Make sure to tighten the cable connector to the sensor. **DO NOT** spin the sensor onto the cable, as this fatigues the cable pins, resulting in a shorted signal and a damaged cable.

For installation in dirty, humid, or rugged environments, it is suggested that the connection be shielded against dust or moisture with shrink tubing or other protective material. Strain relieving the cable/sensor connection can also prolong cable life. Mounting cables to a test structure with tape, clamps, or adhesives minimizes cable whip. See **Figure 3**.

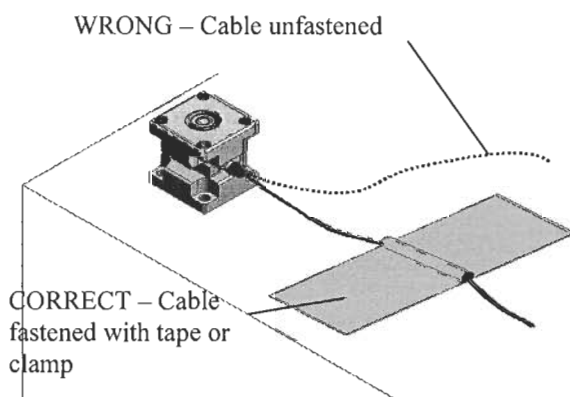

Figure 3 - Cable Strain Relief

4.0 OPERATION

ICP® force link sensors require a constant-current excitation voltage for operation. The enclosed specification sheet provides specific power requirements. Required supply voltage is normally 20 to

30 VDC, while the constant current required ranges from 2 to 20 mA.

PCB standard battery-powered signal conditioners are factory set at 2 mA and may be used to adequately drive a signal for 100 feet. PCB line signal supplies are factory set at 4 mA (and adjustable from 2 to 20 mA), enabling signals to be transmitted over hundreds of feet.

It is necessary to supply the sensor with a 2 to 20 mA constant current at +20 to +30 VDC through a current-regulating diode or equivalent circuit, contained in all PCB signal conditioners. See Guide G-0001E for powering and signal conditioning information pertaining to all ICP® instrumentation.

Most of the signal conditioners manufactured by PCB have an adjustable current feature allowing a choice of input currents from 2 to 20 mA. In general, for lowest noise (best resolution), choose the lower current ranges. When driving long cables (to several thousand feet), use the higher current, up to 20 mA maximum. Consult the factory to determine if higher current settings are required.

Operation requires the connection of the force sensor first to a signal conditioner, then to a readout device (oscilloscope, meter, recorder, or A-to-D board) or to a readout device with built-in ICP® sensor excitation. Tighten the cable to the sensor by hand to ensure good electrical contact.

5.0 POLARITY

Compressive forces upon an ICP® 3-component force link produce a positive-going voltage output. Tensile forces produce a negative-going voltage output. Sensors with reversed polarity are available upon request.

6.0 LOW-FREQUENCY MONITORING

Force link sensors used for applications in short term, steady state monitoring, such as sensor calibration, or short term, quasistatic testing should be powered by signal conditioners that operate in DC-coupled mode. PCB Series 484 Signal Conditioner operates in either AC or DC-coupled mode and may be supplied with gain

features or a zero “clamped” output often necessary in repetitive, positive polarity pulse train applications.

If you wish to learn more about ICP® sensors, consult PCB’s General Signal Conditioning Guide (G-0001E), a brochure outlining the technical specifics associated with piezoelectric sensors. This brochure is available from PCB by request, free of charge.

7.0 DISCHARGE TIME CONSTANT

The discharge time constant (DTC) of the entire transduction system from sensor to readout must be considered when attempting to calibrate an ICP® force sensor by static methods. In order to take full advantage of the long DTC built into the force sensor, it is best to DC couple from the sensor to the readout device. Several dual-mode PCB signal conditioners (e.g., Series 484) use direct coupling techniques to decouple the output signal from the sensor bias voltage. With the output of the signal conditioner coupled to a DC readout, such as a digital voltmeter (DVM) or oscilloscope, the time constant of the sensor is not compromised by AC coupling elsewhere in the system.

When DC coupling to a system, it is important to DC couple the entire system and not just from the sensor to the signal conditioner. The system time constant is determined by the shortest time constant in the system. For this reason, the signal conditioner, as well as the readout device, must be DC coupled.

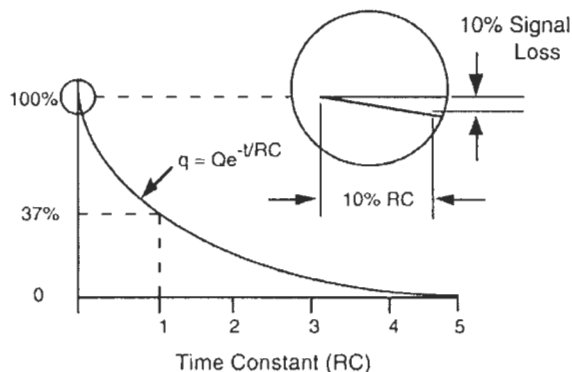

Figure 4 – Discharge Time Constant (DTC) Curve

The discharge time constant represents the decay rate of an input signal. One DTC represents the amount of time taken for the signal to decay to 37% of the initial peak value. As illustrated in **Figure 4**, this is an exponential

decay. Approximately five DTC intervals are needed for a peak signal to naturally decay back to zero.

The rule of thumb for signal discharge, as outlined in **Figure 4**, is this: for the first 10% of the DTC, the signal lost is approximately proportional to the time elapsed.

Step Function Response

For example, a sensor with a 500-second DTC loses approximately 1% of its output level the first five seconds (1% of 500) after the application of a steady state force within the measuring range. In this case, the output reading must be taken within five seconds of the force application for 1% accuracy. If it is impossible to avoid AC coupling somewhere in the sensing system, try to keep the coupling DTC at least an order of magnitude longer than the DTC of the force sensor. This avoids compromising the sensor DTC.

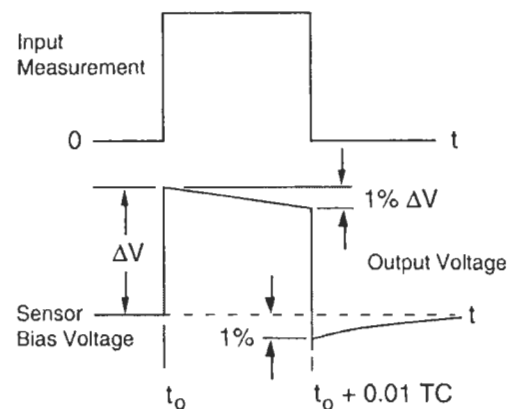

Figure 5 – Step Function Response

8.0 CALIBRATION

A NIST (National Institute of Standards and Technology) traceable calibration graph is supplied with each force sensor certifying its voltage sensitivity (mV/lb). Calibration procedures follow accepted guidelines as recommended by ANSI (American National Standards Institute), ISA (Instrument Society of America), and ISO (International Organization for Standardization). These standards provide the establishment and management of complete calibration systems, thus controlling the accuracy of a sensor’s specifications by controlling measuring and test equipment accuracy. PCB is A2LA accredited for technical competence in the field of calibration, meeting the requirements of ISO/IEC 17025-1999 and ANSI/NCSL 2540-1-1994.

9.0 TROUBLESHOOTING

When a PCB signal conditioner with any of the following indicators are used, turn the power on and observe the voltmeter (or LED's) on the front panel.

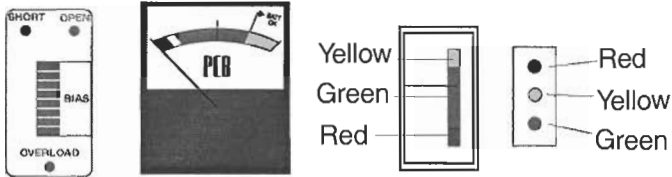

NORMAL OPERATION

INDICATOR	DVM READING	OPERATION
GREEN (Mid-Scale)	8 to 14 V	Proper range for most ICP® sensors.
GREEN (Low End)	3 to 7 V	Proper range for low bias ICP® sensors.
GREEN (High End)	15 to 17 V	Proper range for high bias ICP® sensors.
RED	0 Volts	Short in the sensor, cable, or connections.
YELLOW	24 to 28 V	Open circuit in the sensor, cable, or connections. (Excitation voltage is being monitored.)

Output voltage moves from YELLOW to GREEN slowly until charging is complete. AC coupled signal conditioners require sufficient time to charge the internal coupling capacitor. Allow signal conditioner to charge for approximately 5 discharge time constants for stable operation.

Note: Most PCB force sensors have an output bias of 8-14 VDC. Refer to the specification sheet with this manual for the bias range of the model you are using. If you are using a low bias sensor, the indicator will be at the bottom end of the green portion of the dial indicator, and may even be in the red portion. This is the expected range and indicates proper operation.

10.0 MAINTENANCE

The sensor connector must be kept clean, especially if it is operating in a dusty and/or wet environment. Because the force sensor is of welded construction, it should be returned to the factory for servicing in the event of serious malfunction.

Observe the following precautions in using the sensor:

- Do not exceed the maximum load levels for the force sensor (see specification sheet).
- Do not subject the sensor to temperatures exceeding that of the specification, normally 250°F (121°C).
- Do not apply voltage to the sensor without current-limiting diodes or other current protection.
- Do not apply more than 20 mA of current to the force sensor.
- When mounting the force sensor, observe installation procedures detailed in Section 3.0 and as outlined on the specific sensor installation/outline drawing to avoid overtorquing when mounting.
- Do not apply more than 30 volts to the sensor.
- Avoid metal-to-metal impacts during applications, which can produce high frequency ringing. Electrical low-pass filtering or a damping material can help reduce such effects.
- Do not spin the sensor onto the cable. This may fatigue the cable pins, causing cable damage. Always insert the cable pin into the sensor and tighten the knurled cable nut to the sensor.

ICP® is a registered trademark of PCB Piezotronics, Inc.

	<u>ENGLISH</u>	<u>SI</u>	
Performance			
Sensitivity(± 20 %)(z axis)	0.25 mV/lb	0.06 mV/N	[1]
Sensitivity(± 20 %)(x or y axis)	1.25 mV/lb	0.28 mV/N	[1]
Measurement Range(z axis)	10,000 lb	44.48 kN	
Measurement Range(x or y axis)	4000 lb	17.79 kN	
Maximum Force(z axis)	11,000 lb	48.93 kN	
Maximum Force(x or y axis)	4400 lb	19.57 kN	
Maximum Moment(z axis)	240 ft-lb	325.4 Nm	
Maximum Moment(x or y axis)	325 ft-lb	440.7 Nm	
Broadband Resolution(x or y axis)	0.05 lb-rms	0.222 N-rms	[2]
Broadband Resolution(x or y axis)	0.01 lb-rms	0.04 N-rms	[2]
Upper Frequency Limit	10,000 Hz	10,000 Hz	
Low Frequency Response(-5 %)(z-axis)	0.01 Hz	0.01 Hz	
Low Frequency Response(-5 %)(x or y axis)	0.001 Hz	0.001 Hz	
Non-Linearity	≤ 1 % FS	≤ 1 % FS	[3]
Cross Talk(between x and y axis)	± 3 %	± 3 %	
Cross Talk(between (x or y axis) and z axis)	± 5 %	± 5 %	
Environmental			
Temperature Range	-65 to +250 °F	-54 to +121 °C	
Electrical			
Full Scale Output(Z Direction)	± 2.5 VDC	± 2.5 VDC	
Full Scale Output(X and Y Direction)	± 5 VDC	± 5 VDC	
Discharge Time Constant(z axis)	≥ 50 sec	≥ 50 sec	
Discharge Time Constant(x or y axis)	≥ 500 sec	≥ 500 sec	
Excitation Voltage(all channels)	20 to 30 VDC	20 to 30 VDC	
Constant Current Excitation(all channels)	2 to 20 mA	2 to 20 mA	
Output Impedance	≤ 100 Ohm	≤ 100 Ohm	
Output Bias Voltage	8 to 14 VDC	8 to 14 VDC	
Spectral Noise(1 Hz)(X & Y)	0.003 lb/√Hz	0.0134 N/√Hz	
Spectral Noise(10 Hz)(X & Y)	0.001 lb/√Hz	0.00445 N/√Hz	
Spectral Noise(100 Hz)(X & Y)	0.0004 lb/√Hz	0.00178 N/√Hz	
Spectral Noise(1000 Hz)(X & Y)	0.0001 lb/√Hz	0.000445 N/√Hz	
Spectral Noise(1 Hz)(Z)	0.02 lb/√Hz	0.089 N/√Hz	
Spectral Noise(10 Hz)(Z)	0.005 lb/√Hz	0.0222 N/√Hz	
Spectral Noise(100 Hz)(Z)	0.002 lb/√Hz	0.0089 N/√Hz	
Spectral Noise(1000 Hz)(Z)	0.0005 lb/√Hz	0.00222 N/√Hz	
Output Polarity	Positive	Positive	
Physical			
Stiffness(z axis)	19.4 lb/μin	3.4 kN/μm	[2]
Stiffness(x or y axis)	5.7 lb/μin	1.0 kN/μm	[2]
Size (Height x Length x Width)	3.54 in x 3.15 in x 3.15 in	89.9 mm x 80.0 mm x 80.0 mm	
Weight	96.25 oz	2994 gm	
Housing Material	Stainless Steel	Stainless Steel	
Sealing	Hermetic	Hermetic	
Electrical Connector	4-Pin	4-Pin	
Electrical Connection Position	Side	Side	

OPTIONAL VERSIONS

Optional versions have identical specifications and accessories as listed for the standard model except where noted below. More than one option may be used.

M - Metric Mount

W - Water Resistant Cable

Electrical Connection Position Side Side

NOTES:

[1]Sensitivites are for listed preload. Sensitivites may vary ±5% depending on preload used.

[2]Typical.

[3]Zero-based, least-squares, straight line method.

[4]See PCB Declaration of Conformance PS023 for details.

--	--	--	--

Entered: LK	Engineer: BAM	Sales: RWM	Approved: BAM	Spec Number:
Date: 10/14/2015	Date: 10/14/2015	Date: 10/14/2015	Date: 10/14/2015	28787



^[4]
*All specifications are at room temperature unless otherwise specified.
 In the interest of constant product improvement, we reserve the right to change specifications without notice.
 ICP® is a registered trademark of PCB Group, Inc.*



Phone: 716-684-0001
 Fax: 716-684-0987
 E-Mail: info@pcb.com

PCB Piezotronics Inc. claims proprietary rights in the information disclosed hereon. Neither it nor any reproduction thereof will be disclosed to others without the written consent of PCB Piezotronics Inc.

28786

REVISIONS		
REV	DESCRIPTION	DIN
D	UPDATE SUPPLIED NUT CALLOUT	37815

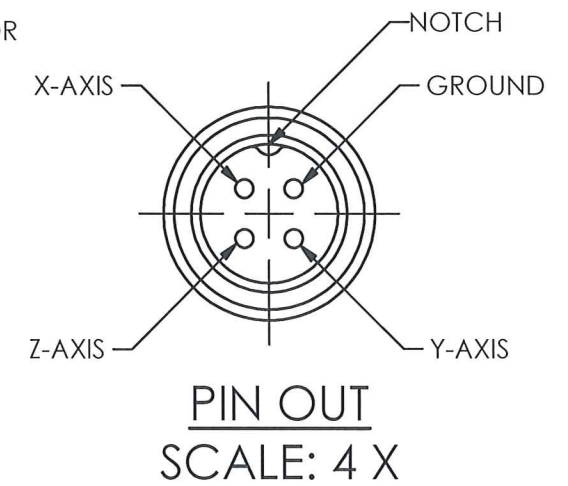
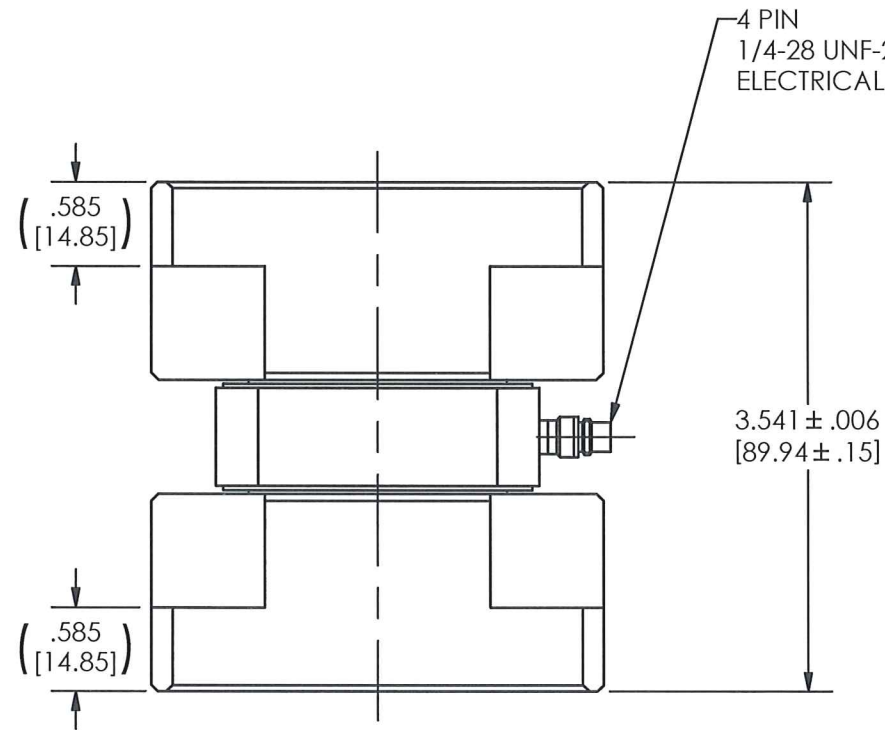
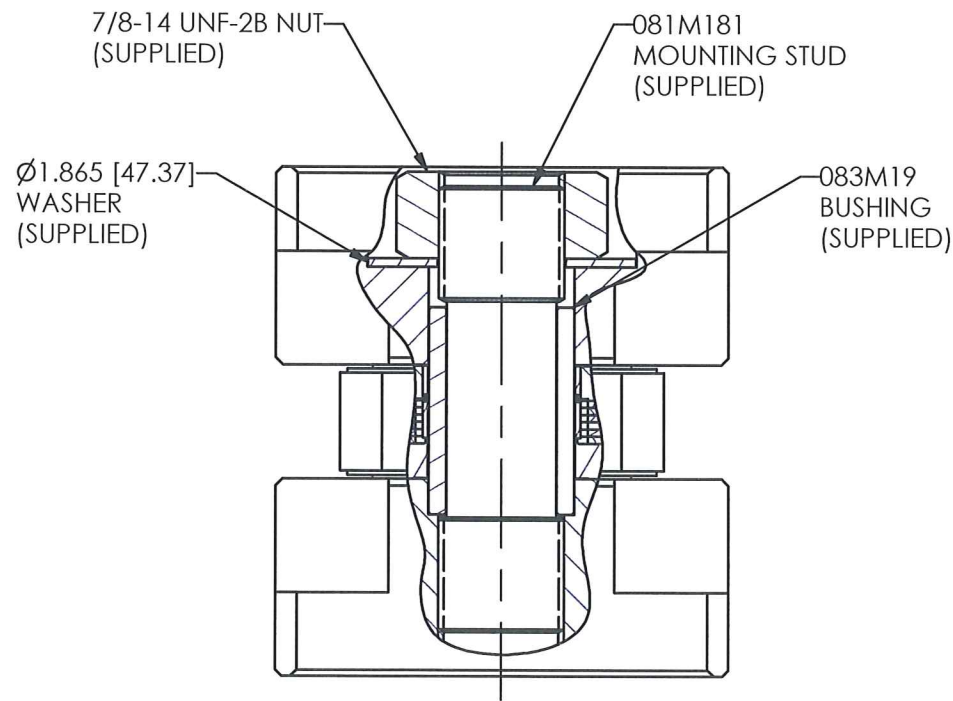
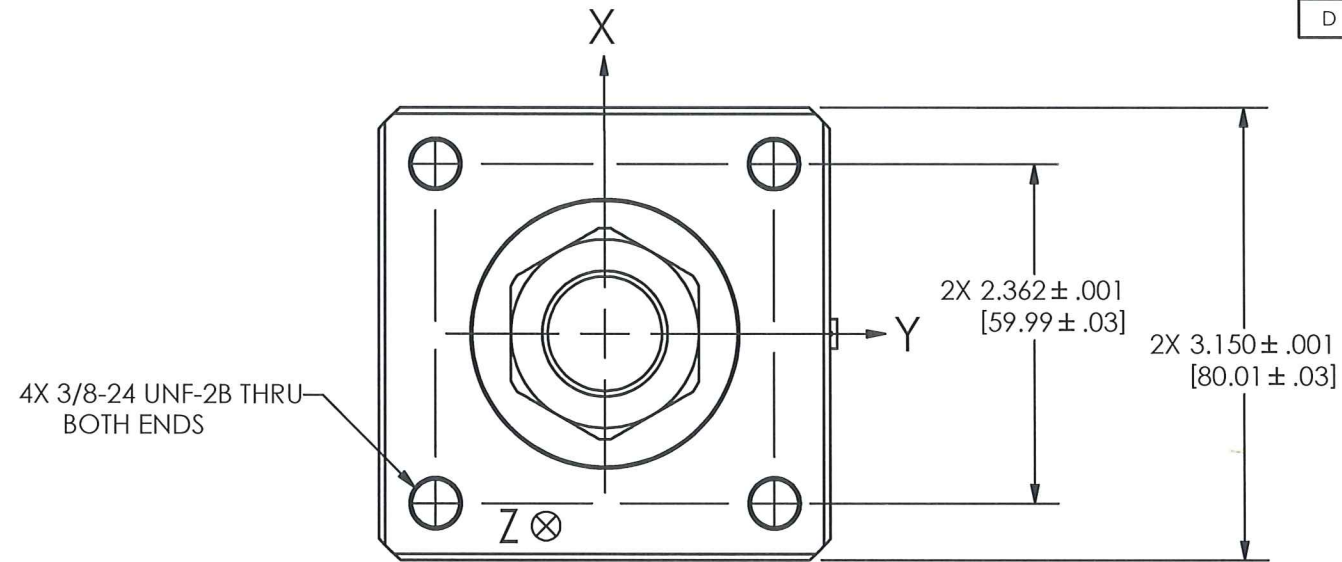

UNLESS OTHERWISE SPECIFIED TOLERANCES ARE:		DRAWN	CHECKED	ENGINEER	 3425 WALDEN AVE. DEPEW, NY 14043 (716) 684-0001 E-MAIL: sales@pcb.com
DIMENSIONS IN INCHES	DIMENSIONS IN MILLIMETERS [IN BRACKETS]	MDP 12/2/11	ECB 12/2/11	BM 12/2/11	
DECIMALS XX ±.03 XXX ±.010	DECIMALS X ±0.8 XX ±0.25	TITLE OUTLINE DRAWING MODEL 261A03 TRIAXIAL FORCE SENSOR			CODE IDENT. NO. 52681
ANGLES ± 2 DEGREES	ANGLES ± 2 DEGREES				DWG. NO. 28786
FILLETS AND RADII .003 - .005	FILLETS AND RADII 0.07 - 0.13	SCALE: .75X	SHEET 1 OF 1		