

PCB Load & Torque (A Division of PCB Piezotronics, Inc.)
 claims proprietary rights in the information disclosed herein.
 Neither it nor any reproduction thereof will be disclosed to
 others without the written consent of PCB Load and Torque.

52238

REVISIONS		
REV	DESCRIPTION	ECO
NR	RELEASED FOR PRODUCTION - 01.26.17, PTE	46403

ISO VIEW
 SCALE 1 / 2

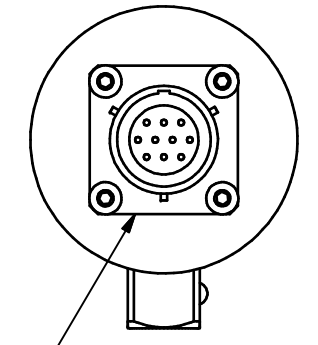
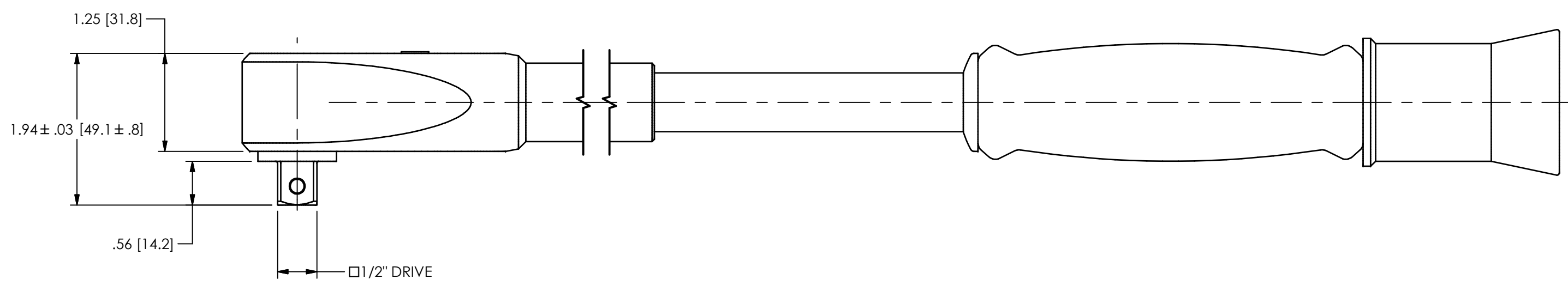
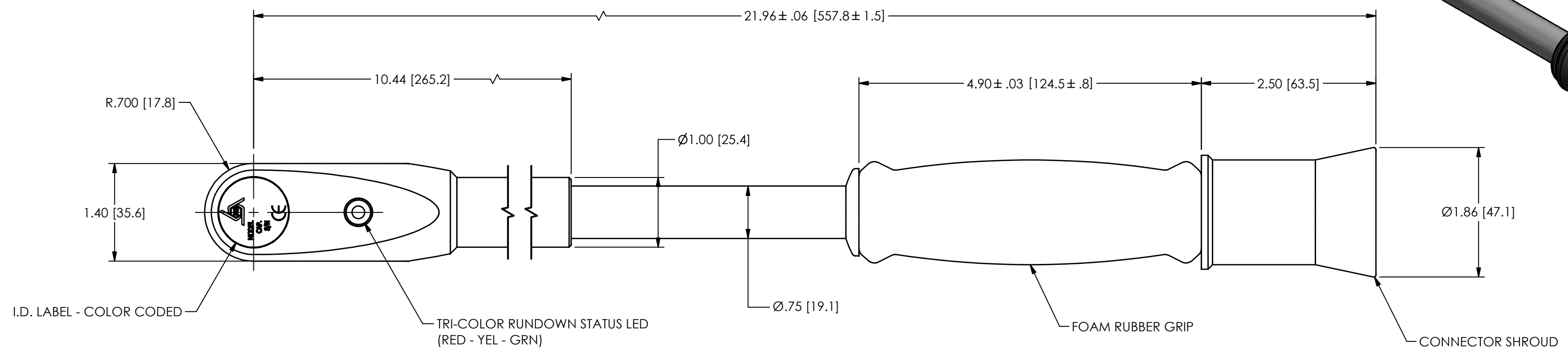
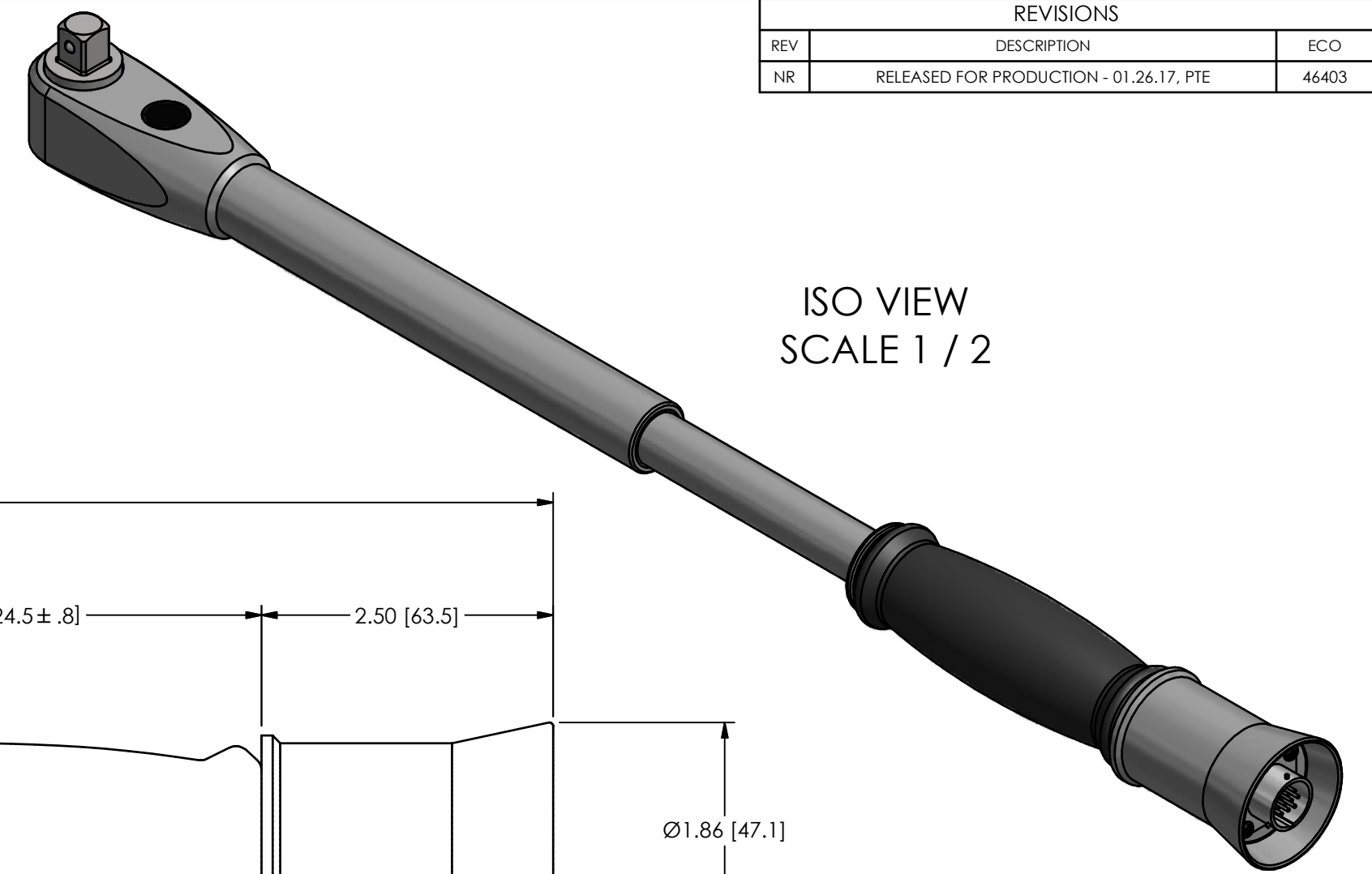

PUSH-TURN CONNECTOR
 (PT02A-12-10P OR EQUIV.)
 WIRING CODE:
 PIN A +EXC.
 PIN B -EXC.
 PIN C +SIG.
 PIN D -SOG.
 PIN E N/C
 PIN F N/C
 PIN G N/C
 PIN H N/C
 PIN J ID GRD
 PIN K ID DATA

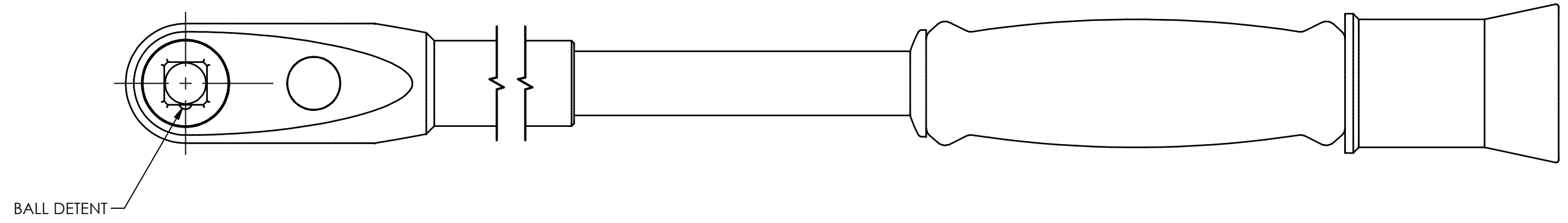

UNLESS OTHERWISE SPECIFIED TOLERANCES ARE:		DRAWN		CHECKED		ENGINEER		PCB LOAD & TORQUE A PCB GROUP COMPANY
DIMENSIONS IN INCHES		PTE	01.20.17	JSD	01.23.17	PTE	01.20.17	
DECIMALS XX ±.01 XXX ±.005	DIMENSIONS IN MILLIMETERS [IN BRACKETS] DECIMALS X ± 0.3 XX ± 0.13	TITLE OUTLINE DRAWING 1/2" SQ. DRIVE - STANDARD HAND TORQUE WRENCH W/LED						24350 Indoplex Circle, Farmington Hills, MI 48335 (248) 888-8260 E-MAIL: l1mfo@pcb.com
ANGLES ± .5 DEGREES	ANGLES ± .5 DEGREES	DWG. NO. 52238						SCALE: 3/4
FILLETS AND RADII .015 MAX	FILLETS AND RADII 0.38 MAX	SHEET 1 OF 1						