



Model 3741D4HB30G
DC ACCELEROMETER
Installation and Operating Manual

**For assistance with the operation of this product,
contact PCB Piezotronics, Inc.**

Toll-free: 800-828-8840
24-hour SensorLine: 716-684-0001
Fax: 716-684-0987
E-mail: info@pcb.com
Web: www.pcb.com



The information contained in this document supersedes all similar information that may be found elsewhere in this manual.

Total Customer Satisfaction – PCB Piezotronics guarantees Total Customer Satisfaction. If, at any time, for any reason, you are not completely satisfied with any PCB product, PCB will repair, replace, or exchange it at no charge. You may also choose to have your purchase price refunded in lieu of the repair, replacement, or exchange of the product.

Service – Due to the sophisticated nature of the sensors and associated instrumentation provided by PCB Piezotronics, user servicing or repair is not recommended and, if attempted, may void the factory warranty. Routine maintenance, such as the cleaning of electrical connectors, housings, and mounting surfaces with solutions and techniques that will not harm the physical material of construction, is acceptable. Caution should be observed to insure that liquids are not permitted to migrate into devices that are not hermetically sealed. Such devices should only be wiped with a dampened cloth and never submerged or have liquids poured upon them.

Repair – In the event that equipment becomes damaged or ceases to operate, arrangements should be made to return the equipment to PCB Piezotronics for repair. User servicing or repair is not recommended and, if attempted, may void the factory warranty.

Calibration – Routine calibration of sensors and associated instrumentation is

recommended as this helps build confidence in measurement accuracy and acquired data. Equipment calibration cycles are typically established by the users own quality regimen. When in doubt about a calibration cycle, a good “rule of thumb” is to recalibrate on an annual basis. It is also good practice to recalibrate after exposure to any severe temperature extreme, shock, load, or other environmental influence, or prior to any critical test.

PCB Piezotronics maintains an ISO-9001 certified metrology laboratory and offers calibration services, which are accredited by A2LA to ISO/IEC 17025, with full traceability to N.I.S.T. In addition to the normally supplied calibration, special testing is also available, such as: sensitivity at elevated or cryogenic temperatures, phase response, extended high or low frequency response, extended range, leak testing, hydrostatic pressure testing, and others. For information on standard recalibration services or special testing, contact your local PCB Piezotronics distributor, sales representative, or factory customer service representative.

Returning Equipment – *Following these procedures will insure that your returned materials are handled in the most expedient manner.* Before returning any equipment to PCB Piezotronics, contact your local distributor, sales representative, or factory customer service representative to obtain a Return

Materials Authorization (RMA) Number. This RMA number should be clearly marked on the outside of all package(s) and on the packing list(s) accompanying the shipment. A detailed account of the nature of the problem(s) being experienced with the equipment should also be included inside the package(s) containing any returned materials.

A Purchase Order, included with the returned materials, will expedite the turn-around of serviced equipment. It is recommended to include authorization on the Purchase Order for PCB to proceed with any repairs, as long as they do not exceed 50% of the replacement cost of the returned item(s). PCB will provide a price quotation or replacement recommendation for any item whose repair costs would exceed 50% of replacement cost, or any item that is not economically feasible to repair. For routine calibration services, the Purchase Order should include authorization to proceed and return at current pricing, which can be obtained from a factory customer service representative.

Warranty – All equipment and repair services provided by PCB Piezotronics, Inc. are covered by a limited warranty against defective material and workmanship for a period of one year from date of original purchase. Contact

PCB for a complete statement of our warranty. Expendable items, such as batteries and mounting hardware, are not covered by warranty. Mechanical damage to equipment due to improper use is not covered by warranty. Electronic circuitry failure caused by the introduction of unregulated or improper excitation power or electrostatic discharge is not covered by warranty.

Contact Information – International customers should direct all inquiries to their local distributor or sales office. A complete list of distributors and offices can be found at www.pcb.com. Customers within the United States may contact their local sales representative or a factory customer service representative. A complete list of sales representatives can be found at www.pcb.com. Toll-free telephone numbers for a factory customer service representative, in the division responsible for this product, can be found on the title page at the front of this manual. Our ship to address and general contact numbers are:

PCB Piezotronics, Inc.
3425 Walden Ave.
Depew, NY 14043 USA
Toll-free: (800) 828-8840
24-hour SensorLineSM: (716) 684-0001
Website: www.pcb.com
E-mail: info@pcb.com

General OPERATING GUIDE

for use with

High Sensitivity DC ACCELEROMETERS

SPECIFICATION SHEET, INSTALLATION DRAWING
AND CALIBRATION INFORMATION ENCLOSED

PCB ASSUMES NO RESPONSIBILITY FOR DAMAGE CAUSED TO THIS PRODUCT AS A RESULT OF PROCEDURES THAT ARE INCONSISTENT WITH THIS OPERATING GUIDE.

1.0 INTRODUCTION

Congratulations on the purchase of a quality, DC acceleration sensor. PCB's high sensitivity DC accelerometers provide optimal performance characteristics in a high quality package. In order to ensure the highest level of performance for this product, it is imperative that you properly familiarize yourself with the correct mounting and installation techniques before attempting to operate this device. If, after reading this manual, you have any additional questions concerning this sensor or its application, feel free to call a factory Application Engineer at 716-684-0001 or your nearest PCB sales representative.

2.0 HIGH SENSITIVITY DC ACCELEROMETERS

High sensitivity DC accelerometers are devices which require stable power. Unlike standard non-amplified piezoresistive accelerometer designs, this stable power is provided by an internal voltage regulator. Therefore PCB's high sensitivity DC accelerometers may be supplied with a positive unregulated DC supply voltage, provided it falls within the specified range of the particular model number. The change in the silicon strain-sensing element is approximately proportional to the applied acceleration. The sensor element is electrically connected in a Wheatstone-bridge circuit. The integral amplifier provides a low impedance output to follow-on instrumentation. These particular accelerometers provide a dc or steady state acceleration measurement capability as opposed to a predetermined low frequency cut off associated with charge or ICP[®] type accelerometers.

Examples where High Sensitivity DC accelerometers may be used:

- Automotive Crash Simulation Sleds
- Automotive Road / Load Rigs
- Aircraft Flutter, Load Testing
- Whole-Body Vibration Studies

Lower range, higher sensitivity DC accelerometers, allow for simple 2 g turn-over testing as a means of determining the health of the unit prior to use. By simply placing the unit in a +1g position and noting the output, then turning the unit on its side to the null position and noting the 0g output error, followed by the same technique, only in the -1g position, the user can verify the health of the accelerometer. The +1g, null and -1g values are now apparent to the user.

General High Sensitivity DC Accelerometer Terms

Excitation-	+ 10 V dc typical. Allowable excitation range (+6 to +30 Vdc)
Sensitivity-	mV/g
ZMO-	Zero Measurand Output (mV output with no acceleration applied)
TSS-	Thermal Sensitivity Shift (sensitivity variation due to temperature change)
TZS-	Thermal Zero Shift (ZMO variation due to temperature change)
Resolution	Minimum acceleration measurement level based on output sensitivity and inherent noise floor of accelerometer

High Sensitivity DC Accelerometers typically have:

- Low-impedance output signal
- Steady-state acceleration measurement capability
- Stable operation over temperature
- Low cross axis sensitivity

PCB's High Sensitivity DC accelerometers are designed utilizing a MEMS (Micro-Electro-Mechanical Systems) silicon sensor approach. The micro machining design process provides sensor design flexibility, reliability & stability over time. Compared to standard strain gages, silicon sensor accelerometers have a much higher gage factor. The sensor element of the 3741 series features a proof mass, ringframe, and an attachment system between the two. These features are micromachined from the same single-crystal silicon wafer. The sensor is connected as a bridge element in the circuit. The electrical characteristics of one portion of the bridge increases while the other decreases, when exposed to acceleration. The sensor element itself is kept small through the use of cutting edge processes such as DRIE (Deep Reactive Ion Etching). Ruggedness is enhanced through the use of mechanical stops on the two outer wafers to restrict the travel of the proofmass. Gas damping is used to mitigate high frequency inputs. An on-board voltage regulator allows an excitation range of +6 to +30 Vdc with less than or equal to 5 mA current draw. The positive output signal line increases with acceleration while the negative line decreases proportionally. The output lines have a common mode voltage of +2.5 Vdc above circuit ground.

Consult the individual accelerometer data sheet on how to order the particular model most appropriate for your application. Adhesive mounting plates and triaxial mounting blocks are available. If you have any questions or concerns regarding optional configurations, consult the Vibration Division's product catalog or contact a PCB factory representative.

4.0 INSTALLATION OVERVIEW

PCB's high sensitivity DC accelerometers are supplied with a silicone jacketed, shielded, multi-conductor, integral cable assembly. With each conductor being 30 AWG, Teflon coated. The supplied cable length for a standard DC accelerometer is 10 ft. or 120 in. (~3 m). Custom cable length requirements should be specified at time of ordering. When applications involve very long cable runs, the user is advised to take into consideration the added resistance of the cable wires and additional capacitance values, as this may affect the voltage available at the accelerometers input voltage regulator. Ensure the recommended torque is used for the supplied 4-40 mounting cap screws. The 3741 is packaged in a hard anodized aluminum case, 0.3 in. high, with a footprint of 0.85 in. by 1.0 in.

The high sensitivity DC accelerometer output signal is considered a differential signal which should be routed to a differential amplifier or bridge conditioner (see Fig. 6). The bridge conditioner should supply a regulated dc supply and have proper amplification features. Although a

simple unregulated DC voltage supply is an acceptable condition for operation, bridge conditioning equipment typically has ZMO adjustment capability and standard connector accessories included which provide a "plug & play" environment.

Excitation input and Voltage output wiring conform to the following color coding practice.

- + Excitation input (red)
- excitation input (black),
- + signal output (yellow)
- signal output (white).

Multi-pin connectors: For accelerometer versions with detachable cabling, make connection by inserting the sensor's mating pins onto the cable connector's mating sockets. Then thread the connector into place by turning the cable connector's outer shell onto the accelerometer's electrical connector.

4.1 SCREW MOUNT

This mounting technique requires smooth, flat contact surfaces for proper operation and is recommended for permanent and/or secure installations. Screw mounting is recommended when testing at high frequencies.

STEP 1: First, prepare a smooth, flat mounting surface, then drill and tap mounting holes for mounting as shown in Figure 3 and in accordance with the enclosed **Installation Drawing**.

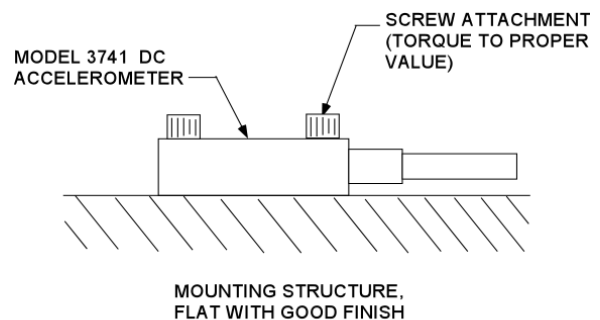

Figure 3. Mounting Surface Preparation

A precision-machined mounting surface with a minimum finish of 32 μin (0.0008 mm) is recommended. (If, and only if, it is not possible to properly prepare the test

structure mounting surface, consider adhesive mounting as a possible alternative). Inspect the area, checking that there are no burrs or other foreign particles interfering with the contact surface.

STEP 2: Wipe clean the mounting surface and spread on a light film of grease, oil, or similar coupling fluid prior to installation.

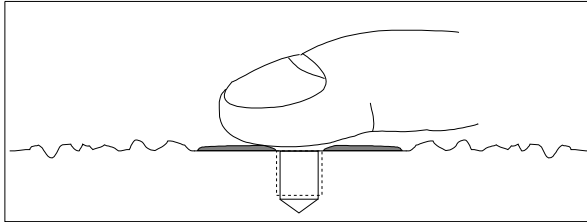

Figure 4. Mounting Surface Lubrication

Adding a coupling fluid improves vibration transmissibility by filling small voids in the mounting surface and increasing the mounting stiffness. For semi-permanent mounting, substitute epoxy or another type of adhesive.

STEP 3: Attach supplied washers, insert screws through hole in accelerometer case, and torque to specified value per **Installation Drawing**.

NOTE: *It is important to use a torque wrench during this step. Under torquing the sensor may not adequately couple the device; over torquing may result in screw failure.*

4.2 ADHESIVE MOUNT

Adhesives like hot glue and wax perform well for temporary installations whereas two-part epoxies and quick-bonding gels (super glue) provide a more permanent installation. PCB recommends mounting DC accelerometers via an adhesive mounting base. The base acts as a sacrificial part allowing safe removal of accelerometer after test is completed.

NOTE: *Adhesively mounted sensors often exhibit a reduction in high-frequency range. Generally, smooth surfaces and stiff adhesives provide the best high frequency response.*

METHOD 1 - Adhesive Mounting Base

This method involves attaching a base to the test structure, then securing the sensor to the base. This allows for easy removal of the accelerometer. Contact the PCB factory representative for optional mounting plate details.

STEP 1: Prepare a smooth, flat mounting surface. A minimum surface finish of 32 μin (0.0008 mm) generally works best.

STEP 2: Attach mounting screws of the sensor to the flat side of the appropriate adhesive mounting base according to the guidelines set forth in **STEPS 2 and 3** of the Screw Mount Procedure presented above.

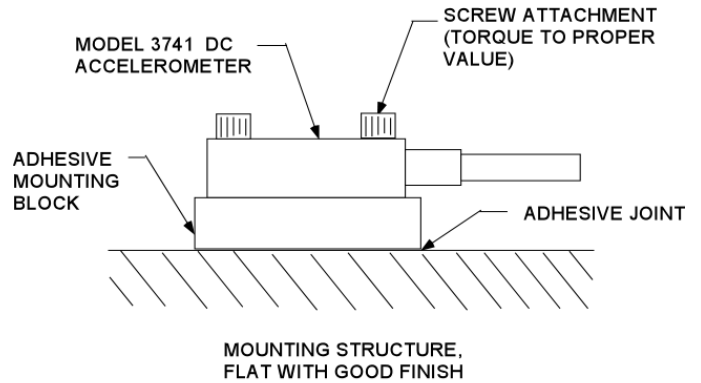

Figure 5. Mounting Base: Adhesive Installation

STEP 3: Place a small portion of adhesive on the underside of the mounting base/block. Firmly press down on the assembly to displace any extra adhesive remaining under the base.

When the accelerometer/base/block assembly is to be removed, unscrew the accelerometer from its' mounting base / block, prior to removal of base/block from test article.

METHOD 2 - Direct Adhesive Mount

Caution: It is recommended to use a mounting base with high sensitivity DC accelerometers (**Method 1**), if at all possible! Method 2 should be avoided, as a general rule, to avoid damage to the accelerometer during removal.

STEP 1: Prepare a smooth, flat mounting surface. A minimum surface finish of 32 μin (0.0008 mm) generally works best.

STEP 2: Place a small portion of adhesive on the underside of the sensor. Firmly press down on the top of the assembly to displace any adhesive. Be aware that excessive amounts of adhesive can make sensor removal difficult. Also, adhesive that may invade the mounting holes in the sensor will compromise future ability to screw mount the unit.

4.2-1 ADHESIVE MOUNT REMOVAL (other than wax)

Caution: It is usually difficult or near impossible to remove a direct adhesive mounted high sensitivity DC transducer without damaging it. That is, adhesive mounted with cyanoacrylate or epoxy, without use of an intermediary mounting base. However, adhesive mounting is often used for temporary installation or when the test object surface cannot be adequately prepared for screw mounting.

NOTE: *A chemical debonder should always be used to avoid sensor damage. Care should be exercised to avoid excessive force being applied to case body during removal.*

To avoid damaging the accelerometer, a de-bonding agent must be applied to the adhesive prior to sensor removal. With so many adhesives in use (everything from super glues, dental cement, epoxies, etc), there is no universal de-bonding agent available. The de-bonder for the Loctite 454 adhesive that PCB offers is Acetone. If you are using anything other than Loctite 454, you will have to check with the individual manufacturers for their de-bonding recommendations. The de-bonding agent must be allowed to penetrate the surface in order to properly react with the adhesive, so it is advisable to wait a few minutes before removing the sensor.

After the de-bonding agent has softened the adhesive, use a gentle shearing (or twisting) motion (by hand only) to remove the sensor from the test structure.

5.0 CABLING

5.1 Units with integral connectors

Care and attention to cable installation and cable condition is essential as the reliability and accuracy of any measurement system is no better than that of its weakest link. Due to the nature of vibration and shock measurements, all sensor cables will ultimately fatigue and fail. Good installation practice will extend the life of a cable, however, it is highly recommended to keep spare cables on hand to enable continuation of the test in the event of a cable failure.

STEP 1: Ascertain that you have the correct cable type.

Note: Most high sensitivity DC accelerometers have integral cable connections; therefore the cable leads at the opposite end from the accelerometer are the main focus and will apply to the specific connector plugs associated with follow-on electronics/signal conditioning equipment.

One cable type cannot satisfy all applications. Industrial applications often require shielded, twisted-pair cables to

reduce the effects of EMI and RFI that is present near electrical motors and machinery. Teflon-jacketed cabling may be necessary to withstand corrosive environments and higher temperatures. Feel free to contact a factory representative for a specific recommendation on cables that are best suited for your application.

STEP 2: Connect the cable to the accelerometer.

A small amount of thread-locking compound placed on the connector threads prior to attachment helps secure the cable during testing. In wet, oily, or dirty environments, the connection can be sealed with silicone rubber sealant, O-rings, and flexible, heat-shrink tubing.

Multi-Conductor Cables: Make accelerometer cable connection to appropriate connector plug via soldering or crimping leads to plug sockets. Specific instructions for this activity are completely dependant on the plug required (D-sub, circular, Lemo, Fischer, etc.) to mate to follow-on conditioning equipment's input receptacle. Refer to instrumentation interface guidelines for proper mating of accelerometer cabling.

Pigtail Connections: Certain high sensitivity DC accelerometers are provided with lightweight cables having "Pigtail" connections. This type of connection reduces overall weight and incidence of connection intermittency under shock conditions. In the event of a cable or connection failure, the cables may be repaired in the field simply by re-soldering the stripped leads to the exposed pins on the sensor. (Check the **Installation Drawing** to determine pin functions). In many cases, it is also helpful to protect the solder joint with heat-shrink tubing or epoxy. It should be noted that cable breaks too close to the accelerometer case, may not be repairable due to insufficient cable material for repair.

NOTE: *If you do not have the experience or resources to attach pigtail leads, consult PCB to discuss factory attachment. Damage to internal electronics may be caused by excessive heat during soldering and such failure is not covered by warranty.*

STEP 3: Route the cable to the signal conditioner, making certain to relieve stress on the sensor/cable connection. Also, minimize cable motion by securing it with tape, clamps or ties at regular intervals.

Common sense should be used to avoid physical damage and minimize electrical noise. For instance, avoid routing cables near high-voltage wires. Do not route cables along floors or walkways where they may be stepped on or become contaminated. To avoid ground loops, shielded cables should have the shield grounded at one end only, typically at the signal conditioner.

STEP 4: Finally, connect the remaining cable end to the signal conditioner.

6.0 Signal Conditioning

For optimum performance and flexibility, high sensitivity DC accelerometers benefit from a good stable, low noise dc power supply for excitation (Fig. 6). It should be regulated and stable to within 0.1% or better. Noise and ripple should be equally low, since noise will be transmitted directly to the signal leads of the bridge. However, an unregulated DC supply may be used due to the high sensitivity DC accelerometer having its own on-board voltage regulator. The signal should be connected to a good instrumentation grade differential input amplifier. The amplifier should have high input impedance (>1 MΩ) and good common mode rejection. The amplifier should also have adequate bandwidth to accommodate the measurement application.

NOTE: Damage to the sensor elements resulting from the application of incorrect power, or the use of an unapproved power source, is NOT covered by warranty.

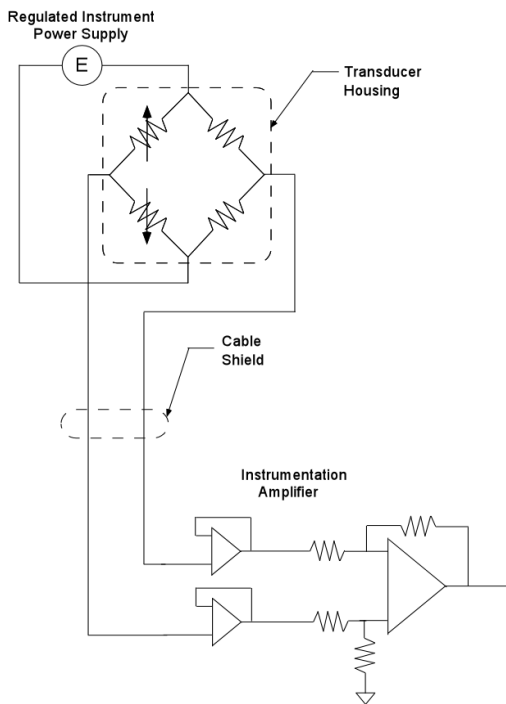

Figure 6. Typical DC Accelerometer Signal Conditioning System Schematic

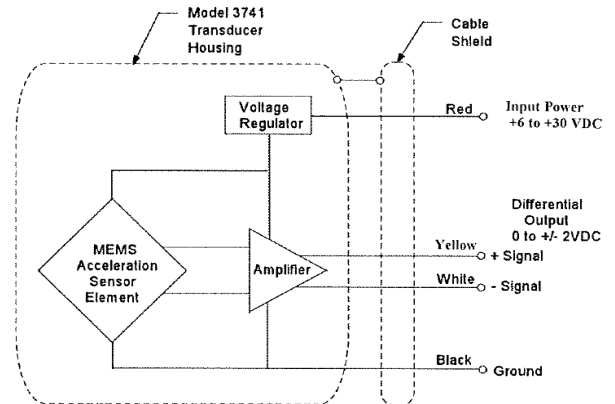

Figure 7. Typical High Sensitivity DC Accelerometer System Schematic

In general, battery-powered devices offer versatility for portable, low-noise measurements, whereas line-powered units provide the capability for continuous monitoring. Note; High sensitivity DC Accelerometers feature on-board differential amplification.

7.0 OPERATING

NOTE: Always operate the accelerometer within the limitations listed on the enclosed **Specification Sheet**. Operating the device outside these parameters can cause temporary or permanent damage to the sensor.

8.0 ACCELEROMETER CALIBRATION

Accelerometer calibration provides, with a definable degree of accuracy, the necessary link between the physical quantity being measured and the electrical signal generated by the sensor. In addition, other useful information concerning operational limits, physical parameters, electrical characteristics, or environmental influences may also be determined. Without this link, analyzing data becomes a nearly impossible task. Fortunately, most sensor manufacturers provide a calibration record that documents the exact characteristics of each sensor. (The type and amount of data varies depending on the manufacturer, sensor type, contractual regulations, and other special requirements).

Under normal conditions, high sensitivity DC sensors are extremely stable, and their calibrated performance characteristics do not change over time. However, the sensor may be temporarily or permanently affected by harsh environments influences or other unusual conditions that may cause the sensor to experience dynamic phenomena outside of its specified operating range.

For these reasons, it is recommended that a recalibration cycle be established for each accelerometer. This schedule is unique and is based on a variety of factors, such as: extent of use, environmental conditions, accuracy requirements, trend information obtained from previous calibration records, contractual regulations, frequency of “cross-checking” against other equipment, manufacturer recommendation, and any risk associated with incorrect readings. International standards, such as ISO 10012-1, provide insight and suggest methods for determining recalibration intervals for most measuring equipment. With the above information in mind and under “normal” circumstances, PCB conservatively suggests a 12- to 24-month recalibration cycle for most piezoresistive accelerometers.

NOTE: *It is good measurement practice to verify the performance of each accelerometer with a calibration device before and after each measurement.*

8.1 RECALIBRATION SERVICE

PCB offers recalibration services for our piezoresistive accelerometers, as well as units produced by other manufacturers. Our internal metrology laboratory is certified to ISO 9001, accredited by A2LA to ANSI/IEC 17025 and ANSI/NCSL Z540-1, complies with ISO 10012-1 (and former MIL-STD-45662A), and uses equipment directly traceable to NIST. Our investment in equipment, traceability and conformance to industry standards ensures accurate calibration against relevant specifications, in a timely fashion.

8.2 BACK-TO-BACK CALIBRATION THEORY

Many companies choose to purchase the equipment necessary to perform the recalibration procedure in house. While this may result in both a savings of time and money, it has also been attributed to incorrect readings and costly errors. Therefore, in an effort to prevent the common mistakes associated with customer-performed calibration, this document includes a broad overview of the Back-to-Back Calibration technique. This technique provides a quick and easy method for determining the sensitivity of a test accelerometer over a wide frequency range.

Back-to-Back Calibration is perhaps the most common method for determining the sensitivity of piezoresistive accelerometers. This method relies on a simple comparison to a previously calibrated accelerometer, typically referred to as a reference standard.

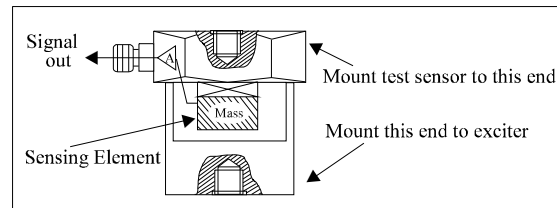

Figure 9. Reference Standard Accelerometer

These high-accuracy devices, which are directly traceable to a recognized standards laboratory, are designed for stability, as well as configured to accept a test accelerometer. By mounting a test accelerometer to the reference standard and then connecting this combination to a suitable vibration source, it is possible to vibrate both devices and compare the data as shown in Figure 10. (Test set-ups may be automated and vary, depending on the type and number of accelerometers being calibrated).

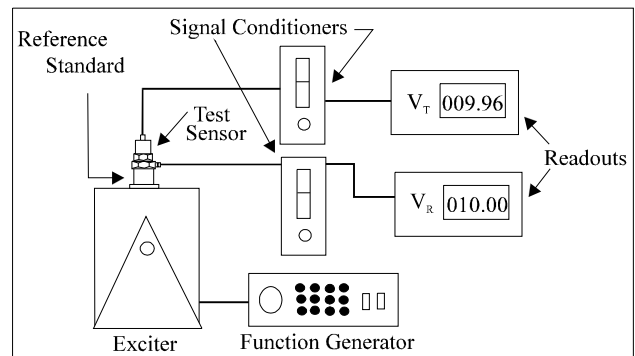

Figure 10. Typical Back-to-Back Calibration System

Because the acceleration is the same on both sensors, the ratio of their outputs (V_T/V_R) must also be the ratio of their sensitivities. With the sensitivity of the reference standard (S_R) known, the exact sensitivity of the test sensor (S_T) is easily calculated by using the following equation:

$$S_T = S_R (V_T/V_R)$$

By varying the frequency of the vibration, the sensor may be calibrated over its entire operating frequency range. The typical response of an unfiltered accelerometer is shown in Figure 11.

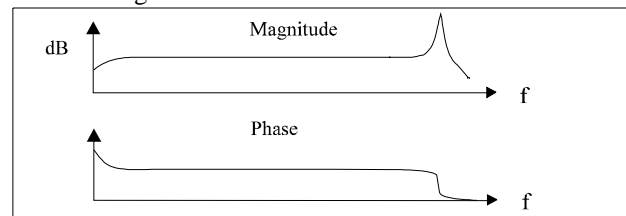

Figure 11. Typical Test Accelerometer Response

8.3 PCB CALIBRATION PROCEDURE

Numerous precautions are taken at PCB to insure accurate and repeatable results. This section provides a brief overview of the primary areas of concern.

Since the Back-to-Back Calibration technique relies on each sensor experiencing an identical acceleration level, proper mounting of the test sensor to the reference standard is imperative. Sensors with mounting holes are attached directly to the reference standard with a stud tightened to the recommended mounting torque. A shouldered mounting stud is typically used to prevent the stud from “bottoming out” in the hole. Both mounting surfaces are precision-machined and lapped to provide a smooth, flat interface according to the manufacturer’s specification. A thin layer of silicone grease is placed between the mating surfaces to fill any imperfections and increase the mounting stiffness. The cables are stress-relieved by first routing them to the shaker head, then to a nearby stationary location. This reduces cable motion and helps to prevent extraneous motion or stresses from being imparted into the system. A typical set-up is shown in Figure 12.

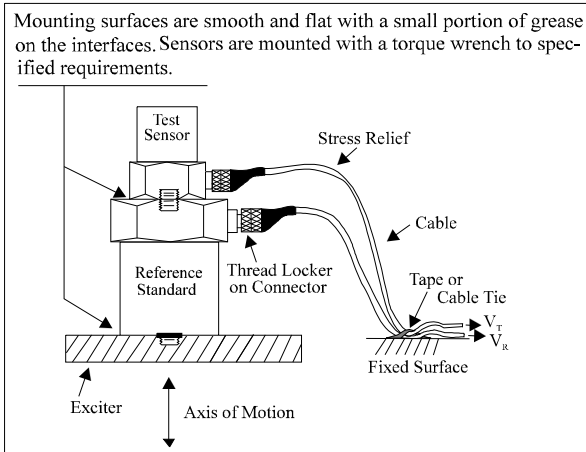

Figure 12. Typical Calibration Set-Up

Adhesively mounted sensors use similar practices. However, in this case, a small portion of quick-bonding gel, or similar temporary adhesive, is used to attach the test sensor to a reference standard designed with a smooth, flat mounting surface.

In addition to mounting, the selection of the proper equipment is critical. Some of the more important considerations include: 1) the reference standard must be specified and previously calibrated over the frequency and/or amplitude range of interest; 2) the shaker should be selected to provide minimal transverse (lateral) motion and minimal distortion; and 3) the quality of the meters, signal generator, and other devices should be selected so as to operate within the limits of permissible error.

8.4 COMMON MISTAKES

Most calibration errors are caused by simply overlooking some of the fundamental principals of dynamics. This section attempts to address some of the more common concerns.

For stud-mount sensors, always mount the accelerometer directly to the reference standard. Ensure that the mounting surfaces are smooth, flat, and free of any burrs. Always use a coupling fluid, such as silicone grease, in the mounting interface to maintain a high mounting stiffness. Mount the sensor according to the manufacturer’s recommended mounting torque.

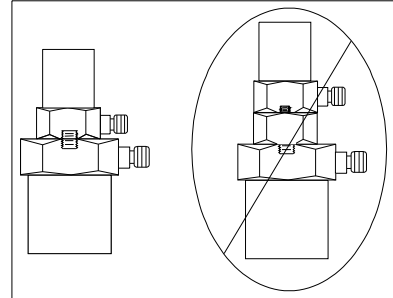

Figure 13. Stud Mounting

For adhesive mount sensors, use a thin, stiff layer of temporary adhesive such as quick-bonding gel or superglue. DO NOT use excessive amounts of glue or epoxy, as the mounting stiffness may be reduced and compromise high-frequency performance. It may also damage the sensor during removal.

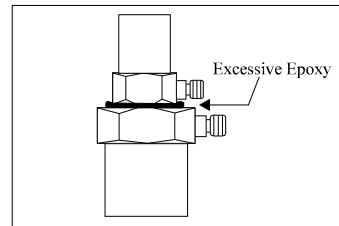

Figure 14. Incorrect Adhesive Mounting

Triaxial accelerometers should always be mounted directly to the reference standard. Use of adaptors may be required for calibration of three individual accelerometers oriented in a triaxial arrangement. The vibration at the test sensor’s sensing element may differ from the vibration at the reference standard due to a “cantilever” effect, seen in Figure 15.

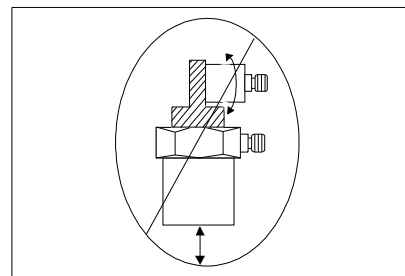

Figure 15. Mounting Triaxial Sensors (Incorrect)

Understand Back-to-Back Calibration limitations. Do not expect the uncertainty of calibration to be any better than $\pm 2\%$. (In fact, the uncertainty may be as high as $\pm 3\%$ or $\pm 4\%$ for frequencies <10 Hz or >2 kHz.) Since large sensors may affect high-frequency accuracy, verify that the test sensor does not mass load the reference standard. Validate your calibration system with another accelerometer prior to each calibration session. Check with the manufacturer for exact system specifications.

8.5 CONCLUSIONS

Without an adequate understanding of dynamics, determining what, when, and how to test a sensor is a difficult task. Therefore, each user must weigh the cost,

time, and risk associated with self-calibration versus utilizing the services of an accredited laboratory.

9.0 SERVICE

See the supplement sheet, contained in this manual, for information on our warranty, service, repair, and return policies and instructions.

When unexpected measurement problems arise, call our 24-hour SensorLineSM to discuss your immediate dynamic instrumentation needs with a factory representative. Dial 716-684-0001.



3425 Walden Avenue, Depew, NY 14043-2495 USA **Vibration Division toll-free** 888-684-0013
24-hour SensorLineSM 716-684-0001 **FAX** 716-685-3886 **E-mail** vibration@pcb.com **Website** www.pcb.com

A PCB GROUP COMPANY

ISO 9001 CERTIFIED

A2LA ACCREDITED to ISO 17025

© 2002 PCB Group, Inc. In the interest of constant product improvement, specifications are subject to change without notice.
PCB and ICP are registered trademarks of PCB Group, Inc. SensorLine is a service mark of PCB Group, Inc.
All other trademarks are properties of their respective owners.

Model Number
3741D4HB30G

DC ACCELEROMETER

Revision: F
ECN #: 29264

Performance

	ENGLISH	SI
Sensitivity(± 5 %)	66.7 mV/g	6.80 mV/(m/s ²)
Measurement Range	± 30 g pk	± 294.2 m/s ² pk
Frequency Range(± 5 %)	0 to 1000 Hz	0 to 1000 Hz
Frequency Range(± 10 %)	0 to 2000 Hz	0 to 2000 Hz
Resonant Frequency	>3 kHz	>3 kHz
Phase Response(100 Hz)	<4°	<4°
Phase Response(200 Hz)	<7°	<7°
Damping Method	Gas	Gas
Damping Ratio(± 0.25)	0.65	0.65
Broadband Resolution(0.5 to 100 Hz)	2.5 mg rms	0.0245 m/s ² rms
Non-Linearity	≤ 1 % FS	≤ 1 % FS
Transverse Sensitivity	≤ 3 %	≤ 3 %
Environmental		
Overload Limit(Shock)	± 10,000 g pk	± 98,100 m/s ² pk
Temperature Range(Operating)	-65 to 250 °F	-53.9 to 121 °C
Temperature Range(Storage)	-65 to 250 °F	-53.9 to 121 °C
Temperature Coefficient of Sensitivity	± 3.0 %	± 3.0 %
Zero g Offset Temperature Coefficient	± 2.0 %FSO	± 2.0 %FSO
Base Strain Sensitivity(Measured at 250 µε)	0.01 g/µε	0.10 (m/s ²)/µε
Electrical		
Excitation Voltage	6 to 30 VDC	6 to 30 VDC
Current Consumption	≤ 7.5 mA	≤ 7.5 mA
Output Impedance	≤ 100 ohm	≤ 100 ohm
Offset Voltage(0 g)	± 50 mVDC	± 50 mVDC
Common Mode Voltage(± 0.1 VDC)	+2.5 VDC	+2.5 VDC
Spectral Noise(1 to 1000 Hz)	387 µg/√Hz	3796 (µm/s ²)/√Hz
Electrical Isolation(Case)	>10 ⁸	>10 ⁸

Physical

Housing Material	Anodized Aluminum	Anodized Aluminum
Sealing	Epoxy	Epoxy
Size (Height x Length x Width)	0.30 in x 1.00 in x .85 in	7.62 mm x 25.4 mm x 21.6 mm
Weight(without cable)	0.35 oz	9.92 gm
Electrical Connector	Integral Cable	Integral Cable
Electrical Connection Position	Side	Side
Cable Termination	Pigtail Ends	Pigtail Ends
Cable Type	010 4-cond Shielded	010 4-cond Shielded
Cable Length	10 ft	3 m
Mounting	Through Holes (2)	Through Holes (2)



All specifications are at room temperature unless otherwise specified.
In the interest of constant product improvement, we reserve the right to change specifications without notice.
ICP® is a registered trademark of PCB Group, Inc.

OPTIONAL VERSIONS

Optional versions have identical specifications and accessories as listed for the standard model except where noted below. More than one option may be used.

NOTES:

- [1] Offset tolerance is based on manufacturers supplied cable length.
- [2] Typical.
- [3] Case and shield to mounting surface or cable leads.
- [4] -65 to +250 °F, ref. 75 °F (-54 to +121 °C, ref. 24 °C)
- [5] FSO = Full Scale Output over the Measurement Range (4VDC).
- [6] Measured at 100 Hz, 1 grms.
- [7] Zero-based, least-squares, straight line method.
- [8] See PCB Declaration of Conformance PS027 for details.

SUPPLIED ACCESSORIES:

- Model 081A103 Mounting screw (2)
- Model ACS-103 Phase and Amplitude Calibration from 2 Hz to +5% of frequency range (1)
- Model M081A103 Mounting screw and washer, M3 x 0.5 thread (2)

OPTIONAL ACCESSORIES:

Model 080A208 Triaxial mounting block

Entered: BLS	Engineer: TCT	Sales: RJL	Approved: BY	Spec Number:
Date: 8/21/08	Date: 8/20/08	Date: 8/21/08	Date: 8/21/08	30070



3425 Walden Avenue, Depew, NY 14043
Phone: 716-684-0001
Fax: 716-685-3886
E-Mail: vibration@pcb.com

PCB Piezotronics Inc. claims proprietary rights in the information disclosed hereon. Neither it nor any reproduction thereof will be disclosed to others without the written consent of PCB Piezotronics Inc.

30066

REVISIONS

REV	DESCRIPTION	ECN	APP'D
D	CHANGED DEPICTED MARKING	24487	DM 6-06
E	UPDATED NOTES	26484	<i>Handwritten initials</i> 6/07

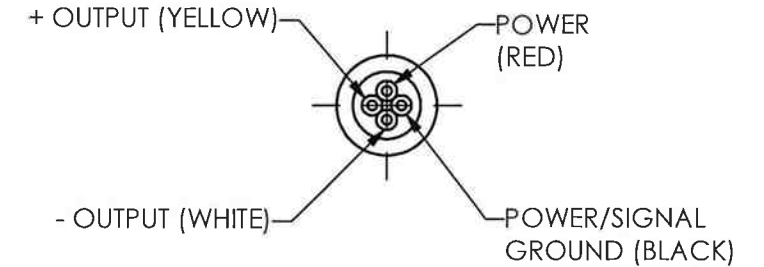
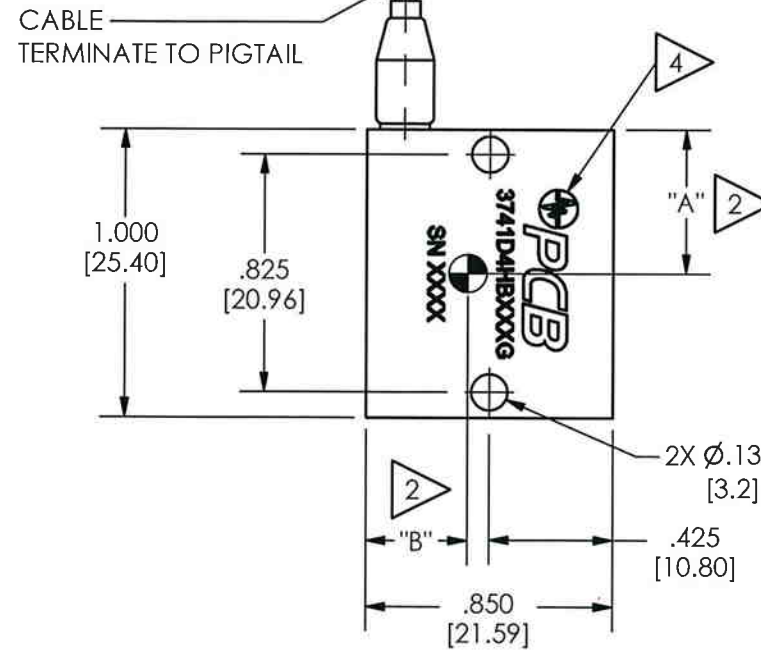

POWER: (RED)
CONNECT TO DC VOLTAGE POWER SUPPLY. SEE SPECIFICATION SHEET FOR PROPER EXCITATION VOLTAGE.

SHIELD:
CASE GROUND

1 MODEL 081A103 MOUNTING SCREW ASSEMBLY (2 SUPPLIED)

1 FOR "M" OPTION MODEL M081A103 MOUNTING SCREW ASSEMBLY (2 SUPPLIED)

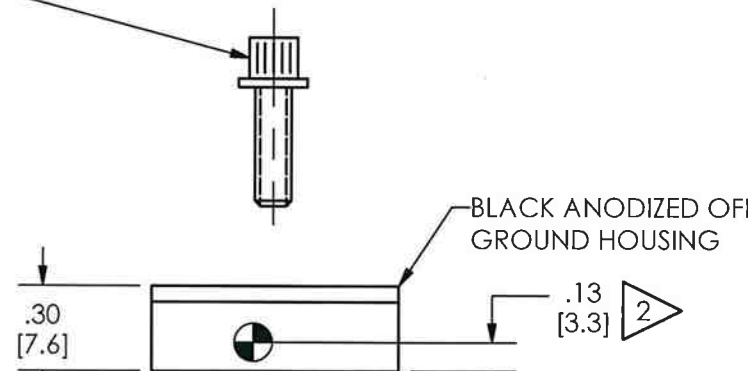

MOUNTING HOLE PREPARATION:
Ø.089 [2.26]
X .22 [5.6] ∇ MIN
4-40 UNC-2B
X .15 [3.8] ∇ MIN

FOR METRIC OPTION MOUNTING HOLE PREPARATION:
Ø.098 [2.45]
X .39 [10.0] ∇ MIN
M3 X .5-6H
X .18 [4.6] ∇ MIN

5.) SEE SHEET 2 OF 2 FOR CABLE STRAIN RELIEF INFORMATION.

4 LASER MARK: PCB LOGO, PCB MODEL #, UNIQUE SN. "XXX" IN MODEL NUMBER INDICATES FS RANGE (eg 3741D4HB200G). SEISMIC MASS LOCATIONS ARE NOT MARKED.

3 RECOMMENDED MOUNTING SURFACE SHOULD BE FLAT TO WITHIN .003 [.08] TIR OVER Ø1.32 [33.34] WITH A $32\sqrt{.08}$ FINISH FOR BEST RESULTS.

2 CG-CENTER OF SEISMIC MEASUREMENT, TOLERANCE ± .03 [± .8].

1 RECOMMENDED MOUNTING TORQUE ON CAP SCREW, 6 IN-LBS [65 N-CM]

UNLESS OTHERWISE SPECIFIED TOLERANCES ARE:

DIMENSIONS IN INCHES		DIMENSIONS IN MILLIMETERS [IN BRACKETS]	
DECIMALS	XX ± .01	DECIMALS	X ± 0.3
	XXX ± .005		XX ± 0.13
ANGLES	± 2 DEGREES	ANGLES	± 2 DEGREES
FILLETS AND RADII	.003 - .005	FILLETS AND RADII	{ 0.07 - 0.13 }

DRAWN	<i>Handwritten</i> 5/20/07	MFG	<i>Handwritten</i> P-R-A 6407
CHK'D	<i>Handwritten</i> 6/8/07	ENGR	<i>Handwritten</i> 6-11-07
APP'D	<i>Handwritten</i> 6/4/07	SALES	<i>Handwritten</i> 6/8/07
TITLE			

INSTALLATION DRAWING
MODEL 3741 SERIES
DC ACCELEROMETER

≥25G	.51 [13.0]	.35 [8.9]
<25G	.55 [14.0]	.55 [14.0]
FS RANGE	"A"	"B"

PCB PIEZOTRONICS
3425 WALDEN AVE. DEPEW, NY 14043
(716) 684-0001 E-MAIL: sales@pcb.com

CODE IDENT. NO. 52681
DWG. NO. 30066

SCALE: 1.5X SHEET 1 OF 2

4 3 2 1

PCB Piezotronics Inc. claims proprietary rights in the information disclosed hereon. Neither it nor any reproduction thereof will be disclosed to others without the written consent of PCB Piezotronics Inc.

REVISIONS			
REV	DESCRIPTION	ECN	APP'D
	- SEE SHEET ONE -		

30066

B

B

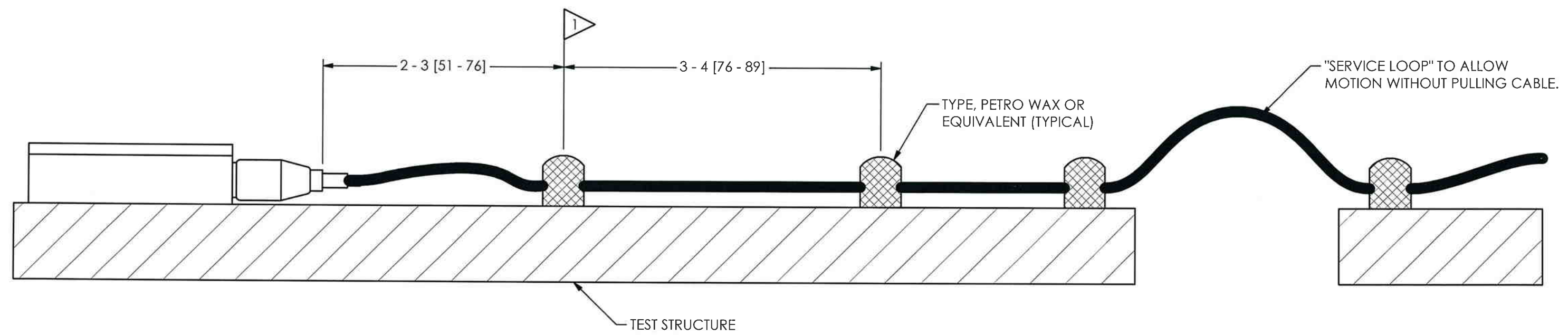

A

A

1 FASTEN CABLE TO TEST STRUCTURE TYPICALLY WITHIN 2-3"[51-76] OF SENSOR. THEN FASTEN AGAIN WITHIN 3-4"[76-101] OF PREVIOUS ATTACHMENT. BETWEEN THE TEST STRUCTURE AND A FIXED STRUCTURE, ALLOW A SERVICE LOOP LARGE ENOUGH TO PREVENT PULLING OF THE CABLE WHEN SHAKING. MORE ATTACHMENT POINTS WILL PROVIDE LESS NOISE IN THE RESULTING DATA. LOOSE CABLES OR PARTS ELSEWHERE ON THE TEST STRUCTURE CAN ALSO GENERATE "NOISE" ON THE SIGNAL RECEIVED FROM THE MODEL 3741 SERIES.

UNLESS OTHERWISE SPECIFIED TOLERANCES ARE:				DRAWN	6/4/07	MFG	P.R.R.	6-8-07	 3425 WALDEN AVE. DEPEW, NY 14043 (716) 684-0001 E-MAIL: sales@pcb.com
DIMENSIONS IN INCHES		DIMENSIONS IN MILLIMETERS [IN BRACKETS]		CHK'D	6/8/07	ENGR	C.C.	6-11-07	
DECIMALS	XX ± .01 XXX ± .005	DECIMALS	X ± 0.3 XX ± 0.13	APP'D	6/14/07	SALES	A.J.	6/8/07	
ANGLES ± 2 DEGREES		ANGLES ± 2 DEGREES		TITLE		INSTALLATION DRAWING MODEL 3711 SERIES DC ACCELEROMETER		CODE IDENT. NO. 52681	
FILLETS AND RADII .003 - .005		FILLETS AND RADII [0.07 - 0.13]		SCALE: 2X		SHEET 2 OF 2		DWG. NO. 30066	

4 3 2 1