



**Model M394C06**

**Handheld shaker, 10 m/sec/sec at 159.2 Hz (for up to 210 grams total weight of sensor, cable and mtg. accessories)**

**Installation and Operating Manual**

**For assistance with the operation of this product,  
contact the PCB Piezotronics, Inc.**

**Toll-free: 716-684-0001  
24-hour SensorLine: 716-684-0001  
Fax: 716-684-0987  
E-mail: [info@pcb.com](mailto:info@pcb.com)  
Web: [www.pcb.com](http://www.pcb.com)**



## Repair and Maintenance

PCB guarantees Total Customer Satisfaction through its “Lifetime Warranty Plus” on all Platinum Stock Products sold by PCB and through its limited warranties on all other PCB Stock, Standard and Special products. Due to the sophisticated nature of our sensors and associated instrumentation, **field servicing and repair is not recommended and, if attempted, will void the factory warranty.**

Beyond routine calibration and battery replacements where applicable, our products require no user maintenance. Clean electrical connectors, housings, and mounting surfaces with solutions and techniques that will not harm the material of construction. Observe caution when using liquids near devices that are not hermetically sealed. Such devices should only be wiped with a dampened cloth—never saturated or submerged.

In the event that equipment becomes damaged or ceases to operate, our Application Engineers are here to support your troubleshooting efforts 24 hours a day, 7 days a week. Call or email with model and serial number as well as a brief description of the problem.

## Calibration

Routine calibration of sensors and associated instrumentation is necessary to maintain measurement accuracy. We recommend calibrating on an annual basis, after exposure to any extreme environmental influence, or prior to any critical test.

PCB Piezotronics is an ISO-9001 certified company whose calibration services are accredited by A2LA to ISO/IEC 17025, with full traceability to SI through N.I.S.T. In addition to our standard calibration services, we also offer specialized tests, including: sensitivity at elevated or cryogenic temperatures, phase response, extended high or low frequency response, extended range, leak testing, hydrostatic pressure testing, and others. For more information, contact your local PCB Piezotronics distributor, sales representative, or factory customer service representative.

## Returning Equipment

If factory repair is required, our representatives will provide you with a Return Material Authorization (RMA) number, which we use to reference any information you have already provided and expedite the repair process. This number should be clearly marked on the outside of all returned package(s) and on any packing list(s) accompanying the shipment.

## Contact Information

PCB Piezotronics, Inc.  
3425 Walden Ave.  
Depew, NY14043 USA  
Toll-free: (800) 828-8840  
24-hour SensorLine: (716) 684-0001  
General inquiries: [info@pcb.com](mailto:info@pcb.com)  
Repair inquiries: [rma@pcb.com](mailto:rma@pcb.com)

For a complete list of distributors, global offices and sales representatives, visit our website, [www.pcb.com](http://www.pcb.com).

## Safety Considerations

This product is intended for use by qualified personnel who recognize shock hazards and are familiar with the precautions required to avoid injury. While our equipment is designed with user safety in mind, the protection provided by the equipment may be impaired if equipment is used in a manner not specified by this manual.

Discontinue use and contact our 24-Hour Sensorline if:

- Assistance is needed to safely operate equipment
- Damage is visible or suspected
- Equipment fails or malfunctions

For complete equipment ratings, refer to the enclosed specification sheet for your product.

## Definition of Terms and Symbols

The following symbols may be used in this manual:



### DANGER

Indicates an immediate hazardous situation, which, if not avoided, may result in death or serious injury.

**CAUTION**

Refers to hazards that could damage the instrument.

**NOTE**

Indicates tips, recommendations and important information. The notes simplify processes and contain additional information on particular operating steps.

**The following symbols may be found on the equipment described in this manual:**



This symbol on the unit indicates that high voltage may be present. Use standard safety precautions to avoid personal contact with this voltage.



This symbol on the unit indicates that the user should refer to the operating instructions located in the manual.



This symbol indicates safety, earth ground.



PCB工业监视和测量设备 - 中国RoHS2公布表

PCB Industrial Monitoring and Measuring Equipment - China RoHS 2 Disclosure Table

部件名称	有害物质					
	铅 (Pb)	汞 (Hg)	镉 (Cd)	六价铬 (Cr(VI))	多溴联苯 (PBB)	多溴二苯醚 (PBDE)
住房	0	0	0	0	0	0
PCB板	X	0	0	0	0	0
电气连接器	0	0	0	0	0	0
压电晶体	X	0	0	0	0	0
环氧	0	0	0	0	0	0
铁氟龙	0	0	0	0	0	0
电子	0	0	0	0	0	0
厚膜基板	0	0	X	0	0	0
电线	0	0	0	0	0	0
电缆	X	0	0	0	0	0
塑料	0	0	0	0	0	0
焊接	X	0	0	0	0	0
铜合金/黄铜	X	0	0	0	0	0
本表格依据 SJ/T 11364 的规定编制。						
0：表示该有害物质在该部件所有均质材料中的含量均在 GB/T 26572 规定的限量要求以下。						
X：表示该有害物质至少在该部件的某一均质材料中的含量超出 GB/T 26572 规定的限量要求。						
铅是欧洲RoHS指令2011/65/ EU附件三和附件四目前由于允许的豁免。						

CHINA RoHS COMPLIANCE

Component Name	Hazardous Substances					
	Lead (Pb)	Mercury (Hg)	Cadmium (Cd)	Chromium VI Compounds (Cr(VI))	Polybrominated Biphenyls (PBB)	Polybrominated Diphenyl Ethers (PBDE)
Housing	O	O	O	O	O	O
PCB Board	X	O	O	O	O	O
Electrical Connectors	O	O	O	O	O	O
Piezoelectric Crystals	X	O	O	O	O	O
Epoxy	O	O	O	O	O	O
Teflon	O	O	O	O	O	O
Electronics	O	O	O	O	O	O
Thick Film Substrate	O	O	X	O	O	O
Wires	O	O	O	O	O	O
Cables	X	O	O	O	O	O
Plastic	O	O	O	O	O	O
Solder	X	O	O	O	O	O
Copper Alloy/Brass	X	O	O	O	O	O

This table is prepared in accordance with the provisions of SJ/T 11364.

O: Indicates that said hazardous substance contained in all of the homogeneous materials for this part is below the limit requirement of GB/T 26572.

X: Indicates that said hazardous substance contained in at least one of the homogeneous materials for this part is above the limit requirement of GB/T 26572.

Lead is present due to allowed exemption in Annex III or Annex IV of the European RoHS Directive 2011/65/EU.

## ***Model 394C06 Handheld Vibration Shaker***

---



### ***Operating Guide with Enclosed Warranty Information***

---

***3425 Walden Avenue, Depew, New York 14043-2495***

***Phone (716) 684-0003***

***Fax (716) 684-3823***

***Toll Free Line 1-800-828-8840***

***MANUAL NUMBER: 18295  
MANUAL REVISION: B  
ECO 51616***

## **Table of Contents**

---

<i>Introduction.....</i>	<i>page 3</i>
<i>Description .....</i>	<i>page 3</i>
<i>Operation.....</i>	<i>page 4</i>
<i>Warnings &amp; Cautions.....</i>	<i>page 6</i>
<i>Warranty.....</i>	<i>page 7</i>
<i>Service .....</i>	<i>page 7</i>
<i>Return Procedure .....</i>	<i>page 7</i>
<i>Total Customer Satisfaction .....</i>	<i>page 8</i>

**Introduction**

Model 394C06 Handheld Shaker is a small, handy, completely self-contained vibration reference source. It is intended for rapid checking of vibration measurement, monitoring and recording systems using piezoelectric accelerometers, as well as other types of vibration transducers having a maximum weight of 210 grams.

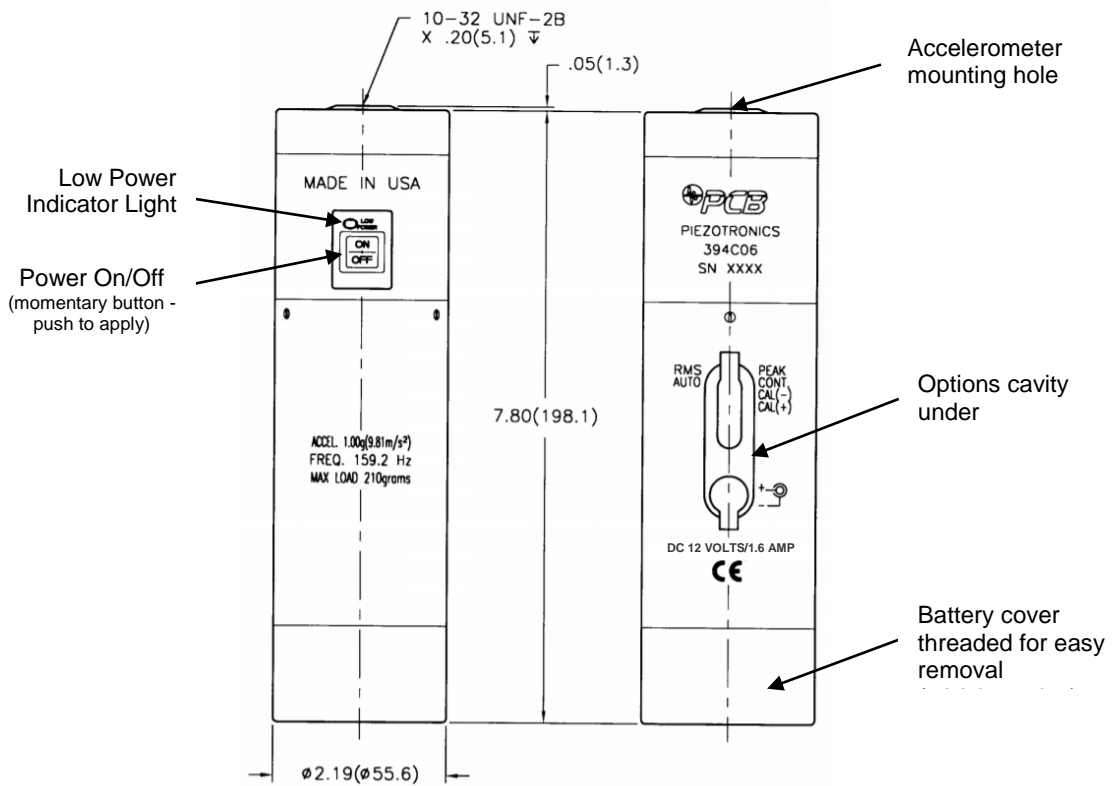

**Figure 1: Model 394C06 Handheld Shaker**

**Description**

Model 394C06 permits accurate adjustment of measuring instrumentation to output a standard acceleration level of 1 g RMS or 1 g peak, with automatic internal compensation for the applied mass. The reference signal may also be used for velocity and displacement, at 10 mms<sup>-1</sup> RMS or 10 mms<sup>-1</sup> peak and 10  $\mu$ m RMS or 10  $\mu$ m peak-to-peak respectively. To change between RMS and peak, depress the corresponding side of the rocker switch in the options cavity of the shaker. For example, to choose RMS, depress the left side of the rocker switch as illustrated in **Figure 1**.

Model 394C06 also provides quick, single sensor validation in complex measurement systems. Confirmation of proper function through the full measurement chain from the sensor, cable(s), signal conditioning through to the data acquisition instrumentation, is extremely useful when configuring large sensor arrays.



A section view of the shaker's vibration head is shown in **Figure 2**. The shaker consists of an electromagnetic exciter, driven by an oscillator at a frequency of 159.2 Hz (1,000 rads<sup>-1</sup>). A small ICP® accelerometer provides a servo feedback to maintain a constant vibration level of 1 g. This enables accelerometers with masses up to 7.4 oz (210 grams) to be excited without their mass influencing the reference level.

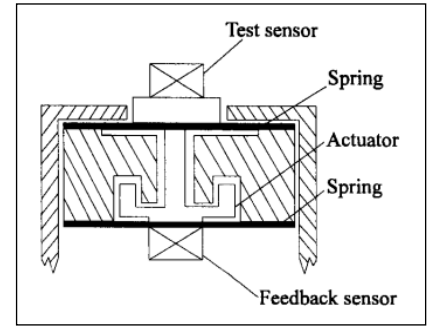

**Figure 2: Cross-Section of Handheld Shaker Vibration Head**

### **Operation**

---

Model 394C06 is a precision instrument and when being used to check the sensitivity of sensors, should be verified prior to use with a reference standard. Use of the shaker is straightforward. Attach an appropriate accelerometer to the shaker using the supplied 10-32 Be-Cu stud or other hardware. The shaker is supplied with adapter mounting studs from 10-32 to a variety of standard and metric threads including the flat pad for adhesive-mount sensors (*See specification sheet for current list of supplied accessories*).

With the accelerometer mounted to the shaker, push the On/Off button (**See Figure 1**). The unit will turn on and internal power to the shaker will be ramped up providing a smooth, gradual increase in vibration amplitude. This process prevents shock-induced overloads to the test sensor. A special reference sensor within the unit constantly measures the g level and internal controls adjust the shaker magnitude to maintain 1 g output while maintaining the frequency of 159.2 Hz. A relatively stiff suspension is used within the shaker that supports any sensor up to 210 grams. The output indicating instrument should now be reading the relevant reference value related to the 1 g input. If reference value is not as expected, check cable connections, consider validating ICP® sensors for turn-on with a battery powered signal conditioner (model 480C02). Following the system adjustment, the shaker is switched off by pressing the On/Off button a second time.

The 394C06 shaker is powered by four (4) "AA" batteries in a removable pack / module (model number 073A15). Battery replacement is simple, rotating the lower section of the shaker counter clockwise will expose the battery pack. To prolong the life of the batteries, model 394C06 automatically switches off after 90 seconds. New battery life depends on the mass applied, estimated between 320 test cycles with a 2 gram mass and 80 cycles with a 210 gram mass.

The unit has several unique features of interest:

- **Continuous Use Option Switch:** In this mode, once the shaker is turned on, it does not shut off until the On/Off button is depressed a second time. The default position of this switch is Auto; the unit turns off automatically after 90 seconds.
- **Peak/RMS Selection:** If a 100 mV/g sensor is on the shaker table, and the unit is in peak mode, then the output is 100 mV/g. If the switch is set to RMS, then the output is 141 mV (**See Figure 3**).
- **External Power Supply:** An optional DC power supply (Model 073A16) is available to power the model 394C06 handheld shaker. It operates off 85-245 VAC, 47-63 Hz input. When this power supply is plugged into the shaker, the internal batteries are automatically disconnected.

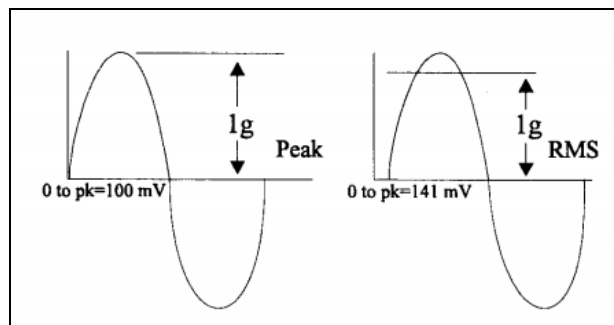

**Figure 3: Peak vs RMS Selection with 100 mV/g Accelerometer**

- **Calibration Check Points:** Calibration of the internal feedback circuit can be verified via test points (located in the options cavity – **see Figure 1**). The measured value in volts AC should agree with the calibration certificate. This is useful for a quick field check of unit integrity, which may be necessary if the shaker is dropped and a reference standard is not immediately available. This test is not a guarantee of shaker function. If the data does not agree with expected values, the shaker should be checked with a calibration standard before continued use.
- **Low Power Indicator:** A low power indicator light is located above the On/Off switch (**See Figure 1**). This light glows when the available power is marginally adequate to drive the shaker (with the mass on the shaker). This indicator does not signify erroneous data. If model 394C06 cannot obtain 1 g at 159.2 Hz, then the unit shuts off. The low power indicator signifies an imminent inability to drive the mass on the shaker because the test sensor is too heavy, the batteries are low on power, or the external power supply is inadequate.

## **Warnings & Cautions**

---

### **Warning 1 – Non-Serviceable**

---

*The power supply/signal conditioner should not be opened by anyone other than qualified service personnel. This product is intended for use by qualified personnel who recognize shock hazards and are familiar with the safety precautions required to avoid injury.*

### **Warning 2 – Improper Use**

---

This equipment is designed with user safety in mind. However, the protection provided by the equipment may be impaired if the equipment is used in a manner not specified by PCB Piezotronics, Inc.

### **Caution 1 – ESD Sensitivity for Cables**

---

*Cables can kill your equipment.* High voltage electrostatic discharge (ESD) can damage electrical devices. Similar to a capacitor, a cable can hold a charge caused by triboelectric transfer, such as that which occurs in the following:

- Laying on and moving across a rug,
- Any movement through air,
- The action of rolling out a cable, and/or
- Contact with a non-grounded person.



#### ***The PCB solution for product safety:***

- Connect the cables only with the AC power off.
- Temporarily “short” the end of the cable before attaching it to any signal input or output.

### **Caution 2 – ESD Sensitivity working area**

---

*ESD considerations should be made prior to performing any internal adjustments on the equipment.* Any piece of electronic equipment is vulnerable to ESD when opened for adjustments. Internal adjustments should therefore be done ONLY at an ESD-safe work area. Many products have ESD protection, but the level of protection may be exceeded by extremely high voltage.

### **Warranty**

---

PCB instrumentation is warranted against defective material and workmanship for 1 year unless otherwise expressly specified. Damage to instruments caused by incorrect power or misapplication, is not covered by warranty. *If there are any questions regarding power, intended application, or general usage, please consult with your local sales contact or distributor.* Batteries and other expendable hardware items are not covered by warranty.

### **Service**

---

Aside from battery replacement, no maintenance is required for this unit. The 394C06 contains no field serviceable parts and is not designed for field repair. Field repair is typically **NOT** recommended and may void any warranty. If factory service is required, return the instrumentation according to the "Return Procedure" stated below. *A repair and/or replacement quotation will be provided prior to servicing at no charge.* Before returning the unit, please consult a factory PCB applications engineer concerning the situation as certain problems can often be corrected with simple on-site procedures.

### **Return Procedure**

---

*To expedite returned instrumentation, contact a factory PCB applications engineer for a RETURN MATERIAL AUTHORIZATION (RMA) NUMBER.* When requesting the RMA, please be prepared to provide the model number, serial number, a brief written description of the problem, your company details, and any other pertinent information. We also recommend a copy of this information should be provided in the package with the instrument.

Customers outside the U.S. should consult their local PCB distributor for information on returning equipment. For exceptions, please contact the International Sales department at PCB to request shipping instructions and an RMA. For assistance, please call (716) 684-0003, or fax us at (716) 684-3823. You may also receive assistance via e-mail at [info@pcb.com](mailto:info@pcb.com) or visit our web site at [www.pcb.com](http://www.pcb.com).

***Total Customer Satisfaction***

---

PCB, a division of PCB Piezotronics, guarantees **Total Customer Satisfaction**. If, at any time, for any reason, you are not completely satisfied with any PCB product, PCB will repair, replace, or exchange it at no charge. You may also choose, within the warranty period, to have your purchase price refunded.

PCB offers to all customers, at no charge, 24-hour phone support. This service makes product or application support available to our customers, day or night, seven days a week. When unforeseen problems or emergency situations arise, call the **PCB Hot Line at (716) 684-0003**, and an application specialist will assist you.



3425 Walden Avenue, Depew, NY 14043-2495

Phone: (716) 684-0003 • USA Fax: (716) 684-3823 • INTL Fax: (716) 684-4703

***ICP® is a registered trademark of PCB Piezotronics, Incorporated,  
which uniquely identifies PCB sensors that incorporate built-in microelectronics.***

Model Number <b>394C06</b>	HAND HELD SHAKER	Revision: K ECN #: 48673
-------------------------------	------------------	-----------------------------

	ENGLISH	SI	
<b>Performance</b>			
Operating Frequency(± 1 %)	159.2 Hz	159.2 Hz	
Acceleration Output(± 3 %)	1.00 g rms	9.81 m/s <sup>2</sup> rms	[6]
Velocity Output	0.39 in/sec rms	9.81 mm/s rms	[7]
Displacement Output	0.39 mil rms	9.81 µm rms	[7]
Transverse Output	≤ 3 %	≤ 3 %	
Distortion(0 to 99 grams load)	≤ 2 %	≤ 2 %	
Distortion(100 to 149 grams load)	≤ 5 %	≤ 5 %	
Distortion(150 to 210 grams load)	≤ 9 %	≤ 9 %	
Maximum Load	7.4 oz	210 gm	[8]
Automatic Switch Off Time	1.0 to 2.5 minutes	1.0 to 2.5 minutes	[9]
Calibration Cycles(2 gram load)	320 cycles	320 cycles	[5]
Calibration Cycles(25 gram load)	600 cycles	600 cycles	[5]
Calibration Cycles(50 gram load)	1600 cycles	1600 cycles	[5]
Calibration Cycles(100 gram load)	400 cycles	400 cycles	[5]
Calibration Cycles(150 gram load)	160 cycles	160 cycles	[5]
Calibration Cycles(210 gram load)	80 cycles	80 cycles	[5]
<b>Environmental</b>			
Temperature Range(Operating)	+15 to +130 °F	-10 to +55 °C	
<b>Electrical</b>			
Ramp-Up time	≤ 3 sec	≤ 3 sec	[1]
Internal Battery(Quantity)	4	4	
Internal Battery(Type)	AA	AA	[2]
DC Power(± 5 %)	12 VDC	12 VDC	[3]
DC Power	1.67 Amps	1.67 Amps	[4][3]
Battery Life(2 gram load)	8 hours	8 hours	[5]
Battery Life(25 gram load)	15 hours	15 hours	[5]
Battery Life(50 gram load)	40 hours	40 hours	[5]
Battery Life(100 gram load)	10 hours	10 hours	[5]
Battery Life(150 gram load)	4 hours	4 hours	[5]
Battery Life(210 gram load)	2 hours	2 hours	[5]
<b>Physical</b>			
Size (Diameter x Height)	2.2 in x 7.8 in	56 mm x 200 mm	
Weight(with batteries)	31 oz	900 gm	[1]
Mounting Thread	10-32 Female	10-32 Female	[10][11]
Mounting Torque(Maximum)	10 in-lb	112 N-cm	[11]

OPTIONAL VERSIONS		
Optional versions have identical specifications and accessories as listed for the standard model except where noted below. More than one option may be used.		
<b>M - Metric Mount</b>		
Acceleration Output(± 3 %)	1.02 g rms	10.0 m/s <sup>2</sup> rms

- NOTES:**
- [1] Typical.
  - [2] Alkaline type recommended for longest service life.
  - [3] This specification for external DC power supply (optional).
  - [4] Maximum.
  - [5] Approximate values, based on automatic switch off time and dependent on type of batteries.
  - [6] Unit supplied set to rms; see manual for peak selection.
  - [7] Calculated values for reference only.
  - [8] Maximum load includes sensor, connector and cabling.
  - [9] Unit supplied set to auto shut off; see manual for continuous use selection.
  - [10] Test sensor should be hand tightened (without tools).
  - [11] Transducer to shaker table.
  - [12] See PCB Declaration of Conformance PS022 for details.

- SUPPLIED ACCESSORIES:**
- Model 073A15 Battery Pack (1)
  - Model 080A109 Petro Wax (1)
  - Model 080A178 Adhesive Mounting Base with 1/2" hex 10-32 Integral Stud (1)
  - Model 080A84 Mounting Base (5-40 to 10-32) (1)
  - Model 080A85 Mounting Base (M3 X 0.5 to 10-32) (1)
  - Model 081A08 Mounting Stud (10-32 to 1/4-28) (1)
  - Model 081B05 Mounting Stud (10-32 to 10-32) (2)
  - Model M081B05 Mounting Stud 10-32 to M6 X 0.75 (1)
  - Model M081B23 Metric mounting stud, 10-32 to M5 x 0.80 long (1)
- OPTIONAL ACCESSORIES:**
- Model 073A16 DC switching power supply (for Model 394C06) (1)
  - Model 080A150 Mounting Base (1/4-28) (1)
  - Model 080B44 3-Pin Mounting Adapter (1)

Entered: LK	Engineer: CPH	Sales: KK	Approved: DY	Spec Number:
Date: 11/5/2018	Date: 11/5/2018	Date: 11/5/2018	Date: 11/5/2018	<b>1345</b>



All specifications are at room temperature unless otherwise specified.  
 In the interest of constant product improvement, we reserve the right to change specifications without notice.  
 ICP® is a registered trademark of PCB Group, Inc.



**Phone: 716-684-0001**  
**Fax: 716-684-0987**  
**E-Mail: info@pcb.com**

081-XXXX-90

PCB Piezotronics Inc. claims proprietary rights in the information disclosed hereon. Neither it nor any reproduction thereof will be disclosed to others without the written consent of PCB Piezotronics Inc.

**STANDARD STUD MOUNT**

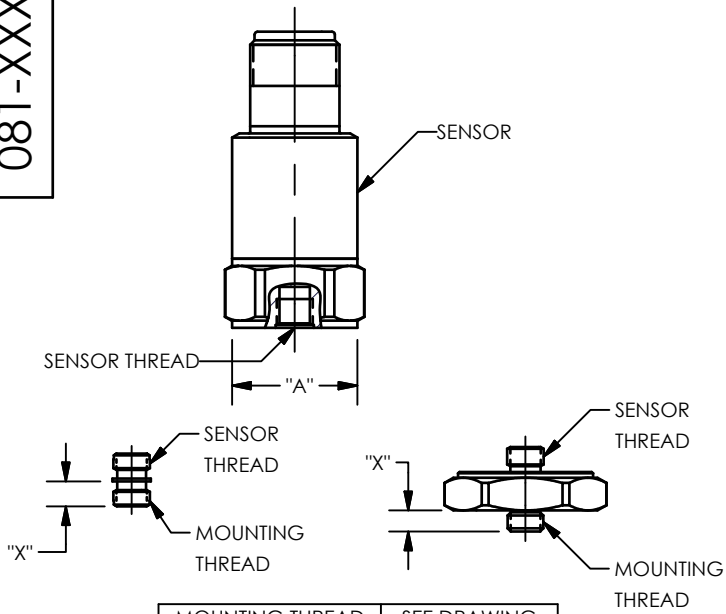

MOUNTING THREAD	SEE DRAWING
5-40	A
M3 X 0.50	B
10-32	C
M5 X 0.80	D
1/4-28	E
M6 X 1.00	F

**"A"**  
5-40  
**MOUNTING INSTRUCTIONS**  
(METRIC DIMENSIONS IN BRACKETS)

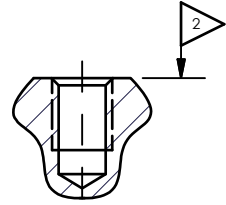

**MOUNTING HOLE PREPARATION:**  
 1.  $\phi .101 [\phi 2.57]$   
 X  $.20 [5.1] \nabla$  MIN.  
 5-40 UNC-2B  
 X  $.15 [3.8] \nabla$  MIN.

4.) RECOMMENDED MOUNTING TORQUE,  
 4-5 INCH POUNDS  
 [45-55 NEWTON CENTIMETERS].

**"B"**  
M3 X 0.50  
**MOUNTING INSTRUCTIONS**  
(ENGLISH DIMENSIONS IN BRACKETS)

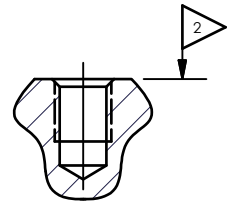

**MOUNTING HOLE PREPARATION:**  
 1.  $\phi 2.5 [\phi .099]$   
 X  $4.6 [1.18] \nabla$  MIN.  
 M3 X 0.50-6H  
 X  $3.3 [1.13] \nabla$  MIN.

4.) RECOMMENDED MOUNTING TORQUE,  
 45-55 NEWTON CENTIMETERS  
 [4-5 INCH POUNDS].

**"C"**  
10-32  
**MOUNTING INSTRUCTIONS**  
(METRIC DIMENSIONS IN BRACKETS)

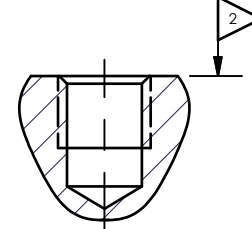

**MOUNTING HOLE PREPARATION:**  
 1.  $\phi .159 [\phi 4.04]$   
 X  $.23 [5.8] \nabla$  MIN.  
 10-32 UNF-2B  
 X  $.15 [3.8] \nabla$  MIN.

4.) RECOMMENDED MOUNTING TORQUE,  
 10-20 INCH POUNDS  
 [113-225 NEWTON CENTIMETERS].

**"D"**  
M5 X 0.80  
**MOUNTING INSTRUCTIONS**  
(ENGLISH DIMENSIONS IN BRACKETS)

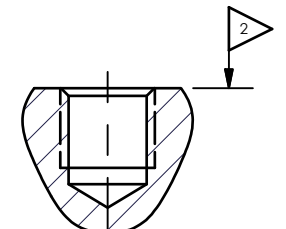

**MOUNTING HOLE PREPARATION:**  
 1.  $\phi 4.22 [\phi .166]$   
 X  $7.62 [300] \nabla$  MIN.  
 M5 X 0.8-6H  
 X  $5.08 [200] \nabla$  MIN.

4.) RECOMMENDED MOUNTING TORQUE,  
 113-225 NEWTON CENTIMETERS  
 [10-20 INCH POUNDS].

REVISIONS		
REV	DESCRIPTION	DIN
R	CHANGED "B" HOLE TOLERANCE	53828

**INTEGRAL STUD MOUNT**

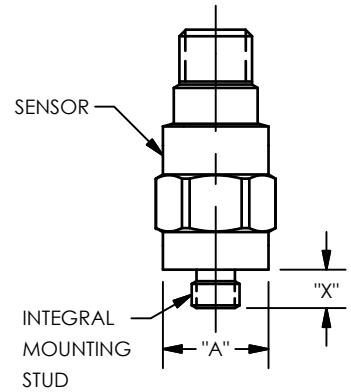

MOUNTING THREAD	SEE DRAWING
5-40	A
M3 X 0.50	B
10-32	C
M5 X 0.80	D
1/4-28	E
M6 X 1.00	F

**"THRU-BOLT" STUD MOUNT**

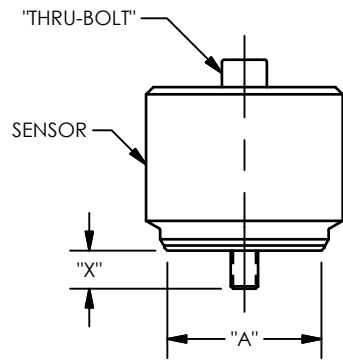

BOLT THREAD	SEE DRAWING
10-32	C
M5 X 0.80	D
1/4-28	E
M6 X 1.00	F
M8 X 1.25	F

**"E"**  
1/4-28  
**MOUNTING INSTRUCTIONS**  
(METRIC DIMENSIONS IN BRACKETS)

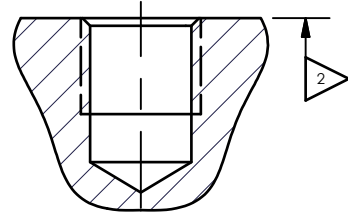

**MOUNTING HOLE PREPARATION:**  
 1.  $\phi .218 [\phi 5.54]$   
 X  $.300 [7.62] \nabla$  MIN.  
 1/4-28 UNF-2B  
 X  $.200 [5.08] \nabla$  MIN.

4.) RECOMMENDED MOUNTING TORQUE,  
 2-5 FOOT POUNDS  
 [3-7 NEWTON METERS].

**"F"**  
M6 X 0.75, M6 X 1.00, M8 X 1.25  
**MOUNTING INSTRUCTIONS**  
(ENGLISH DIMENSIONS IN BRACKETS)

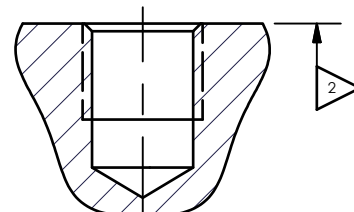

**M6 X 0.75 MOUNTING HOLE PREPARATION:**  
 1.  $\phi 5.31 [\phi .209]$   
 X  $7.62 [300] \nabla$  MIN.  
 M6 X 0.75-6H  
 X  $5.08 [200] \nabla$  MIN.

**M6 X 1.0 MOUNTING HOLE PREPARATION:**  
 1.  $\phi 5.05 [\phi .199]$   
 X  $8.10 [320] \nabla$  MIN.  
 M6 X 1.0-6H  
 X  $6.35 [250] \nabla$  MIN.

4.) RECOMMENDED MOUNTING TORQUE,  
 3-7 NEWTON METERS [2-5 FT POUNDS].

**M8 X 1.25 MOUNTING HOLE PREPARATION:**  
 1.  $\phi 6.75 [\phi .266]$   
 X  $8.64 [340] \nabla$  MIN.  
 M8 X 1.25-6H  
 X  $5.00 [197] \nabla$  MIN.

**"G"**  
**MOUNTING INSTRUCTIONS**  
FOR SPECIAL THREAD LENGTHS  
(METRIC DIMENSIONS IN BRACKETS)

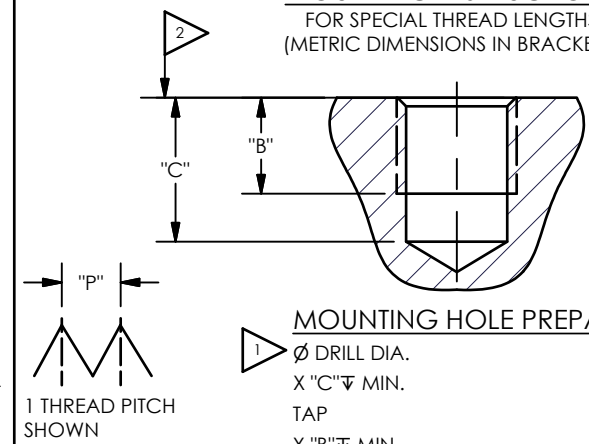

**MOUNTING HOLE PREPARATION:**  
 1.  $\phi$  DRILL DIA.  
 X "C"  $\nabla$  MIN.  
 TAP  
 X "B"  $\nabla$  MIN.

THREAD DEPTH : B = X + 1 THREAD PITCH  
 DRILL DEPTH : C = B + 3 THREAD PITCH  
 SEE A-F FOR APPROPRIATE DRILL AND TAP  
 THREAD PITCH = 1/TPI [P]

- 3.) FOR BEST RESULTS, PLACE A THIN LAYER OF SILICONE GREASE (OR EQUIVALENT) ON INTERFACE PRIOR TO MOUNTING.
- 2. MOUNTING SURFACE SHOULD BE FLAT TO WITHIN .001 (0.03) TIR OVER DIM 'A' WITH A  $63 [1.61] \nabla$  OR BETTER FINISH FOR BEST RESULTS.
- 1. DRILL PERPENDICULAR TO MOUNTING SURFACE TO WITHIN  $\pm 1^\circ$ .

UNLESS OTHERWISE SPECIFIED TOLERANCES ARE:

DIMENSIONS IN INCHES		DIMENSIONS IN MILLIMETERS [IN BRACKETS]	
DECIMALS	XX $\pm .01$ XXX $\pm .005$	DECIMALS	X $\pm 0.3$ XX $\pm 0.13$
ANGLES $\pm 2$ DEGREES		ANGLES $\pm 2$ DEGREES	
CABLE TOLERANCES IN ENGLISH		CABLE TOLERANCES IN METRIC	
1" $\leq$ LENGTH < 1'	= $+1' / -0$	2.54cm $\leq$ LENGTH < 30.5cm	= $+2.54cm / -0$
1' $\leq$ LENGTH < 5'	= $+2' / -0$	30.5cm $\leq$ LENGTH < 1.5m	= $+5.1cm / -0$
5' $\leq$ LENGTH < 100'	= $+6' / -0$	1.5m $\leq$ LENGTH < 30.5m	= $+15.2cm / -0$
100' $\leq$ LENGTH	= $+1' / -0$	30.5m $\leq$ LENGTH	= $+30.5cm / -0$
FILLETS AND RADII .003 - .005		FILLETS AND RADII 0.07 - 0.13	

DRAWN		CHECKED		ENGINEER	
NJF	05/03/23	JDM	05/03/23	MJN	05/03/23
TITLE					
INSTALLATION DRAWING FOR STANDARD 081 SERIES MOUNTING					

**PCB PIEZOTRONICS**  
 AN AMPHENOL COMPANY  
 3425 WALDEN AVE. DEPEW, NY 14043  
 (716) 684-0001 E-MAIL: sales@pcb.com

CODE IDENT. NO. 52681	DWG. NO. 081-XXXX-90
SCALE: NONE	SHEET 1 OF 1

8110

PCB Piezotronics Inc. claims proprietary rights in the information disclosed herein. Neither it nor any reproduction thereof will be disclosed to others without written consent of PCB Piezotronics Inc.

APPLICATION		
NEXT ASS'Y	USED ON	VAR

REVISIONS				
REV	DESCRIPTION	ECN	DATE	APP'D
A	ADDED CE MARK	8829	3/9/98	
B	UPDATED DRAWING	15985	9/6/02	<i>Dmg/02</i>

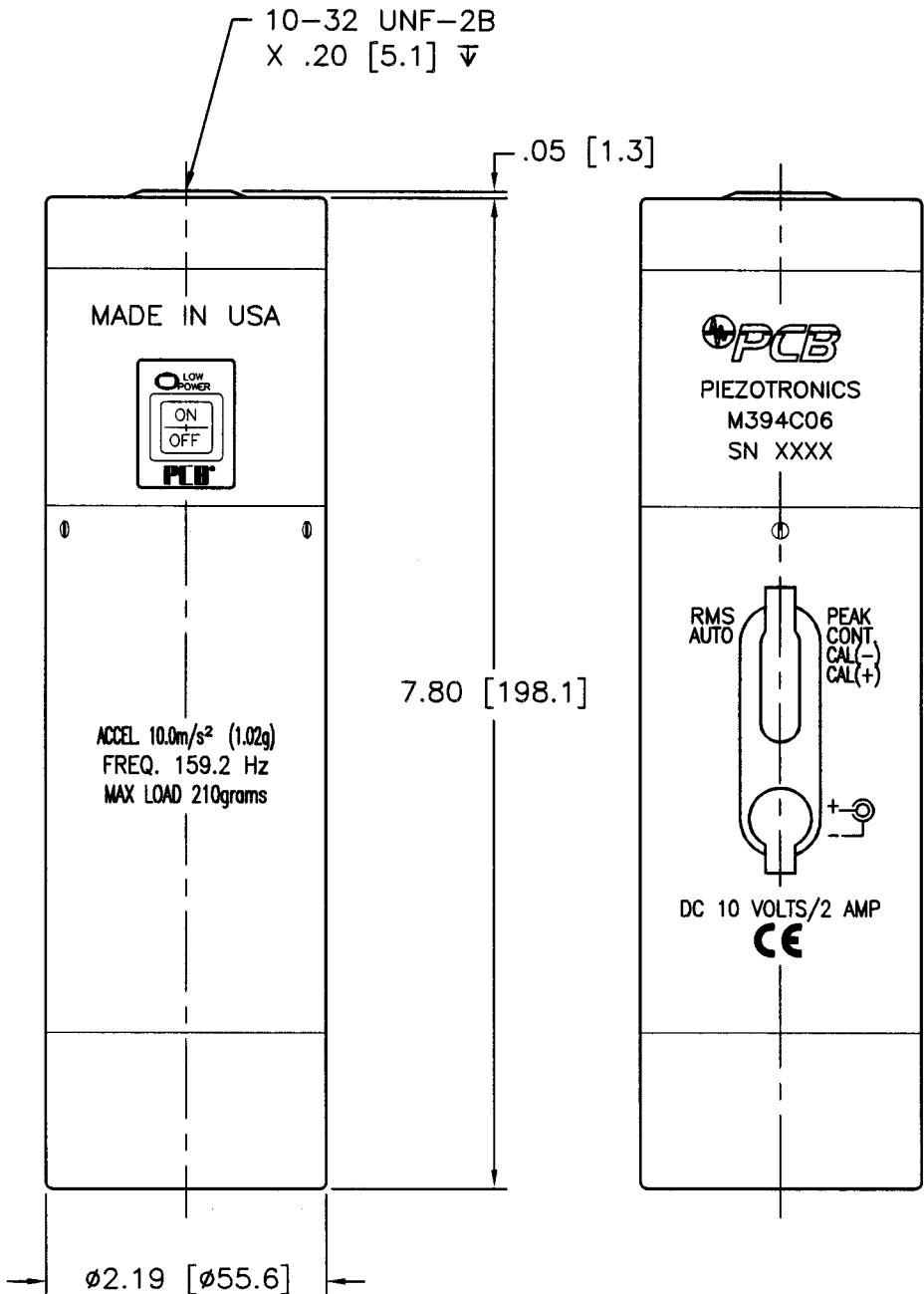

UNLESS SPECIFIED TOLERANCES	
DIMENSIONS IN INCHES	DIMENSIONS IN MILLIMETERS [IN BRACKETS]
DECIMALS XX ±.01 XXX ±.005	DECIMALS XX ±0.3 XXX ±0.13
ANGLES ±2 DEGREES	ANGLES ±2 DEGREES
FILLETS AND RADII .003 - .005	FILLETS AND RADII [0.07 - 0.13]
DD011 REV. B 03/13/98	

DRAWN <i>smj</i> 8/6/02	MFG <i>kg</i> 9/6/02
CHK'D <i>ram</i> 9/6/02	ENGR <i>ys</i> 9/6/02
APP'D <i>Plt</i> 9/6/02	SALES <i>nx</i> 9/6/02
TITLE OUTLINE DRAWING MODEL M394C06 HAND HELD CALIBRATOR	

**PCB PIEZOTRONICS™**  
3425 WALDEN AVE. DEPEW, NY 14043  
(716) 684-0001 EMAIL: SALES@PCB.COM

CODE IDENT. NO. 52681

DWG. NO. 8110

SCALE: 1=1.5 SHEET 1 OF 1