



**Model 137A21**

**ICP® Pressure Sensor**

**Installation and Operating Manual**

**For assistance with the operation of this product,  
contact PCB Piezotronics, Inc.**

**Toll-free: 800-828-8840  
24-hour SensorLine: 716-684-0001  
Fax: 716-684-0987  
E-mail: [info@pcb.com](mailto:info@pcb.com)  
Web: [www.pcb.com](http://www.pcb.com)**



**The information contained in this document supersedes all similar information that may be found elsewhere in this manual.**

**Total Customer Satisfaction** – PCB Piezotronics guarantees Total Customer Satisfaction. If, at any time, for any reason, you are not completely satisfied with any PCB product, PCB will repair, replace, or exchange it at no charge. You may also choose to have your purchase price refunded in lieu of the repair, replacement, or exchange of the product.

**Service** – Due to the sophisticated nature of the sensors and associated instrumentation provided by PCB Piezotronics, user servicing or repair is not recommended and, if attempted, may void the factory warranty. Routine maintenance, such as the cleaning of electrical connectors, housings, and mounting surfaces with solutions and techniques that will not harm the physical material of construction, is acceptable. Caution should be observed to insure that liquids are not permitted to migrate into devices that are not hermetically sealed. Such devices should only be wiped with a dampened cloth and never submerged or have liquids poured upon them.

**Repair** – In the event that equipment becomes damaged or ceases to operate, arrangements should be made to return the equipment to PCB Piezotronics for repair. User servicing or repair is not recommended and, if attempted, may void the factory warranty.

**Calibration** – Routine calibration of sensors and associated instrumentation is

recommended as this helps build confidence in measurement accuracy and acquired data. Equipment calibration cycles are typically established by the users own quality regimen. When in doubt about a calibration cycle, a good “rule of thumb” is to recalibrate on an annual basis. It is also good practice to recalibrate after exposure to any severe temperature extreme, shock, load, or other environmental influence, or prior to any critical test.

PCB Piezotronics maintains an ISO-9001 certified metrology laboratory and offers calibration services, which are accredited by A2LA to ISO/IEC 17025, with full traceability to N.I.S.T. In addition to the normally supplied calibration, special testing is also available, such as: sensitivity at elevated or cryogenic temperatures, phase response, extended high or low frequency response, extended range, leak testing, hydrostatic pressure testing, and others. For information on standard recalibration services or special testing, contact your local PCB Piezotronics distributor, sales representative, or factory customer service representative.

**Returning Equipment** – *Following these procedures will insure that your returned materials are handled in the most expedient manner.* Before returning any equipment to PCB Piezotronics, contact your local distributor, sales representative, or factory customer service representative to obtain a Return

Materials Authorization (RMA) Number. This RMA number should be clearly marked on the outside of all package(s) and on the packing list(s) accompanying the shipment. A detailed account of the nature of the problem(s) being experienced with the equipment should also be included inside the package(s) containing any returned materials.

A Purchase Order, included with the returned materials, will expedite the turn-around of serviced equipment. It is recommended to include authorization on the Purchase Order for PCB to proceed with any repairs, as long as they do not exceed 50% of the replacement cost of the returned item(s). PCB will provide a price quotation or replacement recommendation for any item whose repair costs would exceed 50% of replacement cost, or any item that is not economically feasible to repair. For routine calibration services, the Purchase Order should include authorization to proceed and return at current pricing, which can be obtained from a factory customer service representative.

**Warranty** – All equipment and repair services provided by PCB Piezotronics, Inc. are covered by a limited warranty against defective material and workmanship for a period of one year from date of original purchase. Contact

PCB for a complete statement of our warranty. Expendable items, such as batteries and mounting hardware, are not covered by warranty. Mechanical damage to equipment due to improper use is not covered by warranty. Electronic circuitry failure caused by the introduction of unregulated or improper excitation power or electrostatic discharge is not covered by warranty.

**Contact Information** – International customers should direct all inquiries to their local distributor or sales office. A complete list of distributors and offices can be found at [www.pcb.com](http://www.pcb.com). Customers within the United States may contact their local sales representative or a factory customer service representative. A complete list of sales representatives can be found at [www.pcb.com](http://www.pcb.com). Toll-free telephone numbers for a factory customer service representative, in the division responsible for this product, can be found on the title page at the front of this manual. Our ship to address and general contact numbers are:

PCB Piezotronics, Inc.  
3425 Walden Ave.  
Depew, NY 14043 USA  
Toll-free: (800) 828-8840  
24-hour SensorLine<sup>SM</sup>: (716) 684-0001  
Website: [www.pcb.com](http://www.pcb.com)  
E-mail: [info@pcb.com](mailto:info@pcb.com)

# OPERATION MANUAL FOR FREE FIELD BLAST PRESSURE PROBE Models 137A21, A22, A23

## 1.0 INTRODUCTION

The Series 137A20 Free Field Blast ICP<sup>®</sup> Pressure Probe is designed for measuring field blast and shock tunnel pressure time profiles.

Designed with an ICP<sup>®</sup> built-in source follower amplifier, the 137A20 Series offers sensitivities of 1, 10 and 100 mV/psi with full-scale ranges from 0 to 50, 500 or 5000 psi. The 137A20 Series is constructed with a stable quartz piezoelectric element in an Invar housing

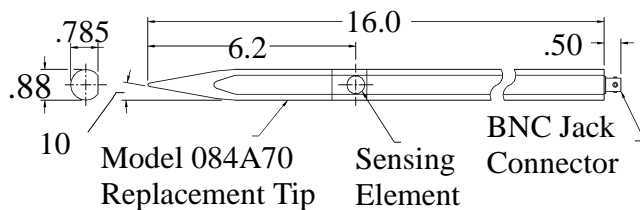

### Series 137A20: Free Field Blast Pencil Probe

## 2.0 INSTALLATION

In field blast measurements, mount the Series 137A20 incident pressure probe in an axial direction to the blast source with the sensing surface of the probe in a vertical plane.

In some cases, where flash temperatures such as those generated by blasts and shock fronts are present, it may be necessary to thermally insulate the diaphragm to minimize signals generated by these effects.

Common black vinyl electrical tape has been found to be an effective insulating material in many cases. One or more layers may be used across the end of diaphragm and adaptor.

A silicone rubber coating approximately .010" thick has also been proven effective in many applications. General Electric RTV type 106 is recommended. Apply the rubber coating to the surface of the diaphragm and allow it to cure in accordance with the manufacturer's instructions. (If you have ordered the ablative coated models, further protection will not be necessary.)

## 3.0 OPERATION

Using suitable cable, connect the sensor to one of PCB's Series 480, 481, 482, 483, or 484 signal conditioners or equivalent power supply. If using a PCB line power unit, the equipment will supply the 137A20 with a 2 to 20 mA constant current at +20 to +30 VDC through a current-regulating circuit. If using a battery-operated unit, the constant current is 2 mA. See Guide G-0001B for powering and signal utilization information pertinent to all ICP<sup>®</sup> instrumentation.

Switch power on and observe reading of bias monitoring voltmeter on front panel of signal conditioner.

If indicator is in green section of indicator panel, the IC amplifier is producing proper bias (8 to 14 VDC), the cable connections are normal, and the system is ready to operate.

If the pointer moves into the red area of the fault monitor meter, output is zero and a short is indicated. The short could be located in amplifier cable connectors or power unit.

If the pointer moves into the yellow area of the fault monitor meter, an open circuit is indicated with full power supply voltage.

An open circuit could be the result of a faulty amplifier, an open cable or open connectors. Check to be sure connectors are properly mated. Some PCB power units feature fault LEDs in place of a fault meter. Instead of a pointer, the fault LED will light when an open or short circuit condition is present. Allow the sensor to thermally stabilize for about one minute. A signal drift may occur when the cable is connected to the readout instrument. This drift occurs during charging of the coupling capacitor in the power unit. The signal will stabilize in several minutes. Proceed with measurements.

Most line-powered signal conditioners manufactured by PCB have an adjustable current feature allowing a choice of input currents from 2 to 20 mA. In general, for the lowest noise (best resolution), choose the lower current ranges.

**OPERATION MANUAL FOR  
FREE FIELD BLAST PRESSURE PROBE  
Models 137A21, A22, A23**

For driving long cables (to several thousand feet), use the higher current, up to 20 mA maximum. Use of low-capacitance cable (i.e. RG 62/U) and impedance-matching variable resistors are suggested to improve long cable performance characteristics at high frequencies.

### **3.1 POLARITY**

The 137A20 Series produces a positive-going output voltage for increasing pressure output.

### **4.0 LOW-FREQUENCY RESPONSE**

Consult Section 7.0 in General Guide G-0001B for detailed explanation of low-frequency characteristics of ICP<sup>®</sup> instrumentation.

### **5.0 CALIBRATION**

Do not try to calibrate the Series 137A20 statically. The Series 137A20 is calibrated dynamically by PCB using a hydraulic pulse technique.

For best accuracy, use the calibration certificate supplied. Factory recalibration is available for a nominal charge.

### **6.0 MAINTENANCE**

Although ICP<sup>®</sup> sensors have low-output impedance and are not usually affected by moisture, in extremely damp environments it may be well to protect cable connections with shrink tubing.

It is well to observe the following precautions in using the sensor:

1. Do not exceed specified maximum range.
2. Do not subject sensor to temperatures exceeding temperature shown on specification sheet.
3. Do not apply voltage to sensor without current-limiting diodes or other current protection.
4. Do not apply more than 20 mA of current to the sensor.

Field repair of the piezoelectric element or amplifier of the Series 137A20 is not practicable. Thus, should a sensor in this series require servicing, refer to the warranty sheet.

**CAUTIONARY NOTE:** If sensors are left outside overnight, they should be coated with silicone oil and covered. The protective silicone oil or grease coating should also be applied when the sensors are operated in a humid or rainy environment.

®ICP is a registered trademark of PCB Piezotronics

Model Number  
**137A21**

# ICP® PRESSURE SENSOR

Revision: J  
ECN #: 34582

**Performance**

Measurement Range(for ±1V output)  
Sensitivity(± 15 %)  
Maximum Pressure  
Resolution  
Resonant Frequency  
Rise Time(Incident)  
Non-Linearity

**ENGLISH**

1 kpsi  
1.0 mV/psi  
5 kpsi  
100 mpsi  
≥ 500 kHz  
≤ 6.5 μ sec  
≤ 1.0 % FS

**SI**

6895 kPa  
0.145 mV/kPa  
34,475 kPa  
0.69 kPa  
≥ 500 kHz  
≤ 6.5 μ sec  
≤ 1.0 % FS

[1]

[2]

Temperature Range(Operating)  
Temperature Coefficient of Sensitivity

-100 to +275 °F  
≤ 0.03 %/°F

-73 to +135 °C  
≤ 0.054 %/°C

**Electrical**

Output Polarity(Positive Pressure)  
Discharge Time Constant(at room temp)  
Excitation Voltage  
Constant Current Excitation  
Output Impedance  
Output Bias Voltage

Positive  
≥ 0.2 sec  
20 to 30 VDC  
2 to 20 mA  
≤ 100 ohm  
8 to 14 VDC

**Physical**

Sensing Geometry  
Sensing Element  
Housing Material  
Diaphragm  
Sealing  
Electrical Connector  
Weight

Compression  
Quartz  
Aluminum  
Invar  
Epoxy  
BNC Jack  
12.7 oz

Compression  
Quartz  
Aluminum  
Invar  
Epoxy  
BNC Jack  
360 gm



[3]

All specifications are at room temperature unless otherwise specified.  
In the interest of constant product improvement, we reserve the right to change specifications without notice.

ICP® is a registered trademark of PCB Group, Inc.

**OPTIONAL VERSIONS**

Optional versions have identical specifications and accessories as listed for the standard model except where noted below. More than one option may be used.

**NOTES:**

- [1] Typical
- [2] Zero-based, least-squares, straight line method.
- [3] See PCB Declaration of Conformance PS023 for details.

Entered: <i>omw</i>	Engineer: <i>QPB</i>	Sales: <i>JMM</i>	Approved: <i>EB</i>	Spec Number:
Date: <i>12/8/10</i>	Date: <i>12/8/10</i>	Date: <i>12/8/10</i>	Date: <i>12/8/10</i>	137-1210-80



3425 Malden Avenue, Depew, NY 14043

Phone: 716-684-0001  
Fax: 716-686-9129  
E-Mail: [pressure@pcb.com](mailto:pressure@pcb.com)

137-1010-95

APPLICATION		
NEXT ASS'Y	USED ON	VAR

REVISIONS				
REV	DESCRIPTION	ECN	DATE	APP'D
B	REVISED AND REDRAWN	3926	9/28/92	DM 10/6/92

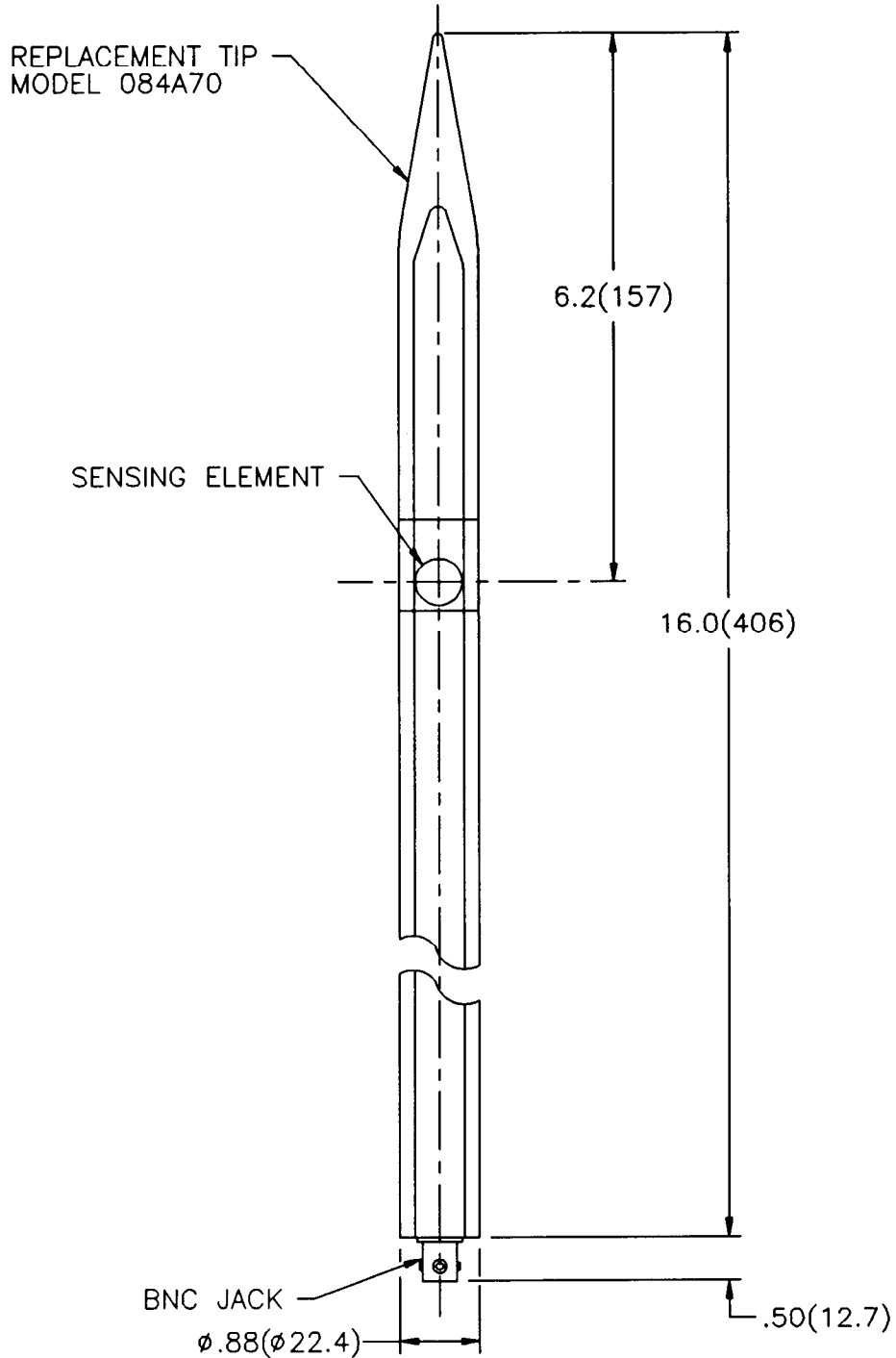

UNLESS SPECIFIED TOLERANCES		DRAWN	CP	10/1/92	MFG	RJA	10/9/92	<b>PCB</b> PIEZOTRONICS, INC. 3425 WALDEN AVE. DEPEW, NEW YORK 14043 PHONE: (716) 884-0001
DIMENSIONS IN INCHES	DIMENSIONS IN MILLIMETERS (IN PARENTHESIS)	CHK'D	DM	10/7/92	ENGR	BC	10/6/92	
DECIMALS XX ±.01	DECIMALS X ±0.3	APP'D	DM	10/7/92	Sales	DM	10/6/92	
XXX ±.005	XX ±0.13	TITLE		OUTLINE DRAWING		CODE	DWG. NO.	
ANGLES ±2 DEGREES	ANGLES ±2 DEGREES			MODEL 137A SERIES		IDENT. NO.	137-1010-95	
FILLETS AND RADII .003 - .005 (0.07 - 0.13)				FREE FIELD BLAST PROBE		SCALE: .5X	SHEET 1 OF 1	