



**Model M119B11**  
**Charge Output Pressure Sensor**  
**Installation and Operating Manual**

**For assistance with the operation of this product,  
contact PCB Piezotronics, Inc.**

**Toll-free: 800-828-8840**  
**24-hour SensorLine: 716-684-0001**  
**Fax: 716-684-0987**  
**E-mail: [info@pcb.com](mailto:info@pcb.com)**  
**Web: [www.pcb.com](http://www.pcb.com)**



## Repair and Maintenance

PCB guarantees Total Customer Satisfaction through its “Lifetime Warranty Plus” on all Platinum Stock Products sold by PCB and through its limited warranties on all other PCB Stock, Standard and Special products. Due to the sophisticated nature of our sensors and associated instrumentation, **field servicing and repair is not recommended and, if attempted, will void the factory warranty.**

Beyond routine calibration and battery replacements where applicable, our products require no user maintenance. Clean electrical connectors, housings, and mounting surfaces with solutions and techniques that will not harm the material of construction. Observe caution when using liquids near devices that are not hermetically sealed. Such devices should only be wiped with a dampened cloth—never saturated or submerged.

In the event that equipment becomes damaged or ceases to operate, our Application Engineers are here to support your troubleshooting efforts 24 hours a day, 7 days a week. Call or email with model and serial number as well as a brief description of the problem.

## Calibration

Routine calibration of sensors and associated instrumentation is necessary to maintain measurement accuracy. We recommend calibrating on an annual basis, after exposure to any extreme environmental influence, or prior to any critical test.

PCB Piezotronics is an ISO-9001 certified company whose calibration services are accredited by A2LA to ISO/IEC 17025, with full traceability to SI through N.I.S.T. In addition to our standard calibration services, we also offer specialized tests, including: sensitivity at elevated or cryogenic temperatures, phase response, extended high or low frequency response, extended range, leak testing, hydrostatic pressure testing, and others. For more information, contact your local PCB Piezotronics distributor, sales representative, or factory customer service representative.

## Returning Equipment

If factory repair is required, our representatives will provide you with a Return Material Authorization (RMA) number, which we use to reference any information you have already provided and expedite the repair process. This number should be clearly marked on the outside of all returned package(s) and on any packing list(s) accompanying the shipment.

## Contact Information

PCB Piezotronics, Inc.  
3425 Walden Ave.  
Depew, NY14043 USA  
Toll-free: (800) 828-8840  
24-hour SensorLine: (716) 684-0001  
General inquiries: [info@pcb.com](mailto:info@pcb.com)  
Repair inquiries: [rma@pcb.com](mailto:rma@pcb.com)

For a complete list of distributors, global offices and sales representatives, visit our website, [www.pcb.com](http://www.pcb.com).

## Safety Considerations

This product is intended for use by qualified personnel who recognize shock hazards and are familiar with the precautions required to avoid injury. While our equipment is designed with user safety in mind, the protection provided by the equipment may be impaired if equipment is used in a manner not specified by this manual.

Discontinue use and contact our 24-Hour Sensorline if:

- Assistance is needed to safely operate equipment
- Damage is visible or suspected
- Equipment fails or malfunctions

For complete equipment ratings, refer to the enclosed specification sheet for your product.

## Definition of Terms and Symbols

The following symbols may be used in this manual:



### DANGER

Indicates an immediate hazardous situation, which, if not avoided, may result in death or serious injury.

**CAUTION**

Refers to hazards that could damage the instrument.

**NOTE**

Indicates tips, recommendations and important information. The notes simplify processes and contain additional information on particular operating steps.

**The following symbols may be found on the equipment described in this manual:**



This symbol on the unit indicates that high voltage may be present. Use standard safety precautions to avoid personal contact with this voltage.



This symbol on the unit indicates that the user should refer to the operating instructions located in the manual.



This symbol indicates safety, earth ground.



PCB工业监视和测量设备 - 中国RoHS2公布表

PCB Industrial Monitoring and Measuring Equipment - China RoHS 2 Disclosure Table

部件名称	有害物质					
	铅 (Pb)	汞 (Hg)	镉 (Cd)	六价铬 (Cr(VI))	多溴联苯 (PBB)	多溴二苯醚 (PBDE)
住房	0	0	0	0	0	0
PCB板	X	0	0	0	0	0
电气连接器	0	0	0	0	0	0
压电晶体	X	0	0	0	0	0
环氧	0	0	0	0	0	0
铁氟龙	0	0	0	0	0	0
电子	0	0	0	0	0	0
厚膜基板	0	0	X	0	0	0
电线	0	0	0	0	0	0
电缆	X	0	0	0	0	0
塑料	0	0	0	0	0	0
焊接	X	0	0	0	0	0
铜合金/黄铜	X	0	0	0	0	0
本表格依据 SJ/T 11364 的规定编制。						
0：表示该有害物质在该部件所有均质材料中的含量均在 GB/T 26572 规定的限量要求以下。						
X：表示该有害物质至少在该部件的某一均质材料中的含量超出 GB/T 26572 规定的限量要求。						
铅是欧洲RoHS指令2011/65/ EU附件三和附件四目前由于允许的豁免。						

CHINA RoHS COMPLIANCE

Component Name	Hazardous Substances					
	Lead (Pb)	Mercury (Hg)	Cadmium (Cd)	Chromium VI Compounds (Cr(VI))	Polybrominated Biphenyls (PBB)	Polybrominated Diphenyl Ethers (PBDE)
Housing	O	O	O	O	O	O
PCB Board	X	O	O	O	O	O
Electrical Connectors	O	O	O	O	O	O
Piezoelectric Crystals	X	O	O	O	O	O
Epoxy	O	O	O	O	O	O
Teflon	O	O	O	O	O	O
Electronics	O	O	O	O	O	O
Thick Film Substrate	O	O	X	O	O	O
Wires	O	O	O	O	O	O
Cables	X	O	O	O	O	O
Plastic	O	O	O	O	O	O
Solder	X	O	O	O	O	O
Copper Alloy/Brass	X	O	O	O	O	O

This table is prepared in accordance with the provisions of SJ/T 11364.

O: Indicates that said hazardous substance contained in all of the homogeneous materials for this part is below the limit requirement of GB/T 26572.

X: Indicates that said hazardous substance contained in at least one of the homogeneous materials for this part is above the limit requirement of GB/T 26572.

Lead is present due to allowed exemption in Annex III or Annex IV of the European RoHS Directive 2011/65/EU.

# OPERATION MANUAL FOR QUARTZ PRESSURE SENSOR Series 118 & 119

## 1.0 INTRODUCTION

The 118 & 119 Series are acceleration-compensated, high pressure sensors primarily developed to measure ballistics chamber pressures for R & D and production testing of ammunition. They may also be used for explosive air blast and other high pressure measurements in extreme shock environments where ultra-fast, micro-second response is required. These types of tests are usually accompanied by large acceleration pulses, which can add considerable error to output signals of un-compensated sensors.

The shoulder seal design features a one-piece diaphragm machined integral with the housing for ruggedness. A ceramic coating is applied to the diaphragm to minimize flash temperature effects.

For applications where strain sensitivity from stress within the mounting port is a concern, the 118B1X and 119B1X utilize a floating clamp-nut design to reduce the effects, where "X" denotes pressure range.

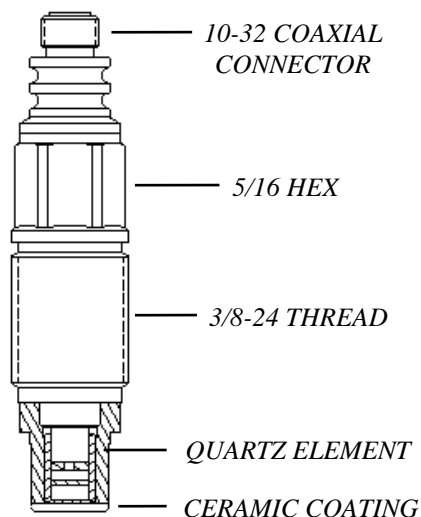

## 2.0 DESCRIPTION

The 118 & 119 Series contain an acceleration-compensated piezo element. The quartz element contains an integral seismic mass that counteracts the acceleration effects of the end piece and diaphragm. This compensation acts to extend the frequency characteristics and enhance the transient response of the sensor.

The machined diaphragm is made from maraging steel, selected because of its high strength and durability. The combination of the short, rigid element and stiff diaphragm give these sensors a high natural frequency and linearity.

## 3.0 INSTALLATION

With a 3/8-24 (M10x1.0 for metric mount) mounting thread and flush diaphragm design, the 118 & 119 Series transducers mount directly in existing ports machined for PCB Series 108 & 109.

Unlike conventional diaphragm type sensors, the 118 & 119 Series are pressure sensitive over the entire frontal area. Extra care should be exercised to avoid bottoming in the mounting hole when recess mounted or when mounting into existing ports.

Install the sensor, using only one of the seals provided, with the aid of a torque wrench to monitor the mounting torque value. The recommended torque range can be found on the installation drawing. Seals should be replaced each time the sensor is re-installed.

### 3.1 MOUNTING IN EXISTING RECESSED PORTS

Before installing the sensor in previously used mounting ports, clean out the residue from previous tests. The port can be cleaned by hand reaming the 1/4 inch diameter hole using a PCB Model 040A end cutting reamer (040A07 for metric mount) guided by PCB Model 041A pilot bushing (M041A for metric mount).

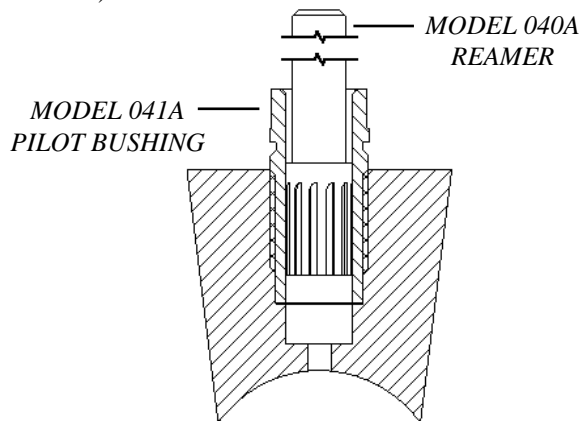

**Existing Recessed Ports**

Pay particular attention to the sealing surface, keeping it free from tool chatter marks, nicks and other imperfections that could adversely affect the seal. If the sealing surface requires re-machining after prolonged use, refer to the installation drawing to ensure that the 1/4 inch hole is deepened to avoid bottoming of the sensor when re-installed.

If waveform distortion occurs during prolonged testing, remove the sensor and clean the residue as illustrated above.

# OPERATION MANUAL FOR QUARTZ PRESSURE SENSOR Series 118 & 119

## 3.2 PREPARING NEW MOUNTING PORTS

Refer to the installation drawing provided in this manual for instructions on mounting hole preparation. For best results, do not deviate from the steps outlined in this drawing.

To assist new mounting port preparation, PCB offers the 040B20 Tooling Kit (040B21 for metric mount). These installation kits provide all of the necessary tooling required to drill, ream, and tap the mounting ports for proper installation of the 108, 109, 118 and 119 Series transducers.

Use good machining practice in preparation of the mounting port, paying particular attention to the seal surface. It is important that this surface be perfectly smooth and free from tool chatter marks, nicks and other imperfections which might cause leaks at high pressures.

## 3.3 RECESSED MOUNT

The recessed installation is shown in the Recessed Mount figure. This type of mounting protects the sensor diaphragm from the effects of high-flash temperatures and particle impingement due to blast effects, thereby prolonging sensor life.

The recommended range of passage diameters is 0.090 to 0.125 inch (2.29 to 3.18 mm) diameter.

The limitation in this type of installation lies in the frequency-limiting effects of the passage due to its length.

The passage behaves like an underdamped second order system; the resonant frequency being determined by the passage length. The length may have a limiting effect on pressure pulse rise time and cause passage ringing in cases where the passage is too long.

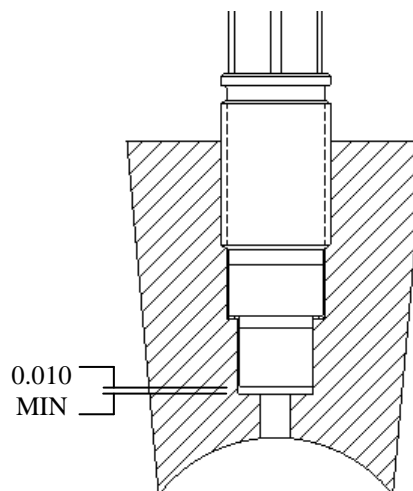

**Recessed Mount**

The following relationship approximates this resonant frequency ( $f_r$ ):

$$f_r = \frac{V}{4L} \quad (\text{Hz}) \quad (\text{EQ. 1})$$

Where:  $f_r$  = Resonant frequency of passage (Hz)

$V$  = Velocity of sound in air (ft/sec)

$L$  = Length of column (ft)

For air at room temperature, (EQ. 1) becomes:

$$f_r = \frac{3300}{L} \quad (\text{EQ. 2})$$

Where:  $L$  = Passage length (in)

## OPERATION MANUAL FOR QUARTZ PRESSURE SENSOR Series 118 & 119

The natural frequency and approximate fastest pressure step rise time for various length passages is shown in the following chart. (Medium, air at 25°C).

PASSAGE LENGTH (in)	PASSAGE RESONANCE (kHz)	APPROX. FASTEST PULSE RISE TIME (uSec)
.050	66	5
.100	33	10
.200	16.5	20
.50	6.6	50
1.0	3.3	100

### Passage Resonance vs. Passage Length

Actual resonant frequencies measured in practice may differ slightly from the chart values. These differences are due to variations in the velocity of propagation of sound in air caused by changes in temperature and pressure of the air in the passage.

For best matching of passage to diaphragm, maintain the 0.010 inch (0.254 mm) clearance ahead of the diaphragm, as shown in the Recessed Mount figure on the previous page.

### 3.4 FLUSH MOUNT

In the flush mount installation, there is no reduced area passage from the sensor diaphragm to the test chamber; rather the sensor diaphragm is mounted flush with (or slightly recessed from) the inside surface of the test chamber.

Use this type of installation only if space or rise time considerations preclude the use of recessed installation.

In severe pyrotechnic environments, sensor life may be severely limited with flush installation.

### 3.5 FLASH TEMPERATURE EFFECTS

The ceramic coating on the diaphragm of these sensors should render the flash thermal effect insignificant in most cases, especially when recessed mounted.

However, if more protection from flash thermal effects is required with the recessed mount, the passage can be filled with silicone grease (DC-4 or equivalent). Several layers of black vinyl electrical tape directly on the diaphragm have proven effective in many cases as well.

Flash temperature effects are usually longer term and will show up as a baseline shift long after the event to be measured has passed.

For flush mount installations, a silicone rubber coating approximately 0.010 inch thick can be effective; GE RTV type 106 is recommended, and is available from PCB as Model 065A67. Follow manufacturer's instructions to apply. It is best to recess the diaphragm 0.010 inch for this type of protection.

### 3.6 INSTALLING CABLES

Use only low-noise treated coaxial cable, such as PCB 003 Series, to connect the sensor to the charge amplifier, in-line voltage amplifier, or other high input impedance readout instrument. To protect the high impedance connection against moisture and contamination, shrink tubing or other equivalent connection protection is recommended. See the following page for typical circuit connections.

Excessive cable motion can generate noise and shorten cable life. For this reason, it is important to support sensor cables by tying them to rigid structures with adequate strain relief loops.

### 4.0 CALIBRATION

PCB 118 & 119 Series sensors are supplied with a calibration certification from the factory. Recalibration services are provided at the factory for a nominal fee.

Several charge amplifiers are specially designed for use with ceramic accelerometers measuring higher frequencies. In general, this type of charge amplifier is not suitable for calibration of quartz pressure sensors by quasi-static means.

Do not attempt to use a charge amplifier which has less than a 5000 second time constant in the "long time constant" mode.

Following thermal stabilization of the sensor, use a high pressure pump with dial reference sensor or a dead weight tester to apply pressure in desired increments to full scale. Release pressure after taking the reading and before proceeding to the next higher pressure level.

A calibration graph can be plotted using output voltage vs. input pressure to determine sensitivity and linearity.



# OPERATION MANUAL FOR QUARTZ PRESSURE SENSOR Series 118 & 119

## 5.0 OPERATION

Most test set-ups will include 118 & 119 Series sensors coupled with charge amplifiers, as shown in the Typical Connection figure below. For applications where the location of the measurement is a long distance from where the data must be read, an in-line amplifier can be used to drive the signal. This configuration reduces the amount of noise in the data and can be seen in the Long Distance Connection figure to the right.

It is important to keep the charge amplifier input cable as short as practical. Input cable capacitance is directly related to cable length and is a major factor in the amount of electrical noise at the output of any charge amplifier.

Depress the ground button of the charge amplifier and adjust electrical zero if necessary. Range the amplifier as required to give the necessary full-scale voltage.

For normal, drift-free operation, switch the charge amplifier time constant selector to “medium” or “short” during use.

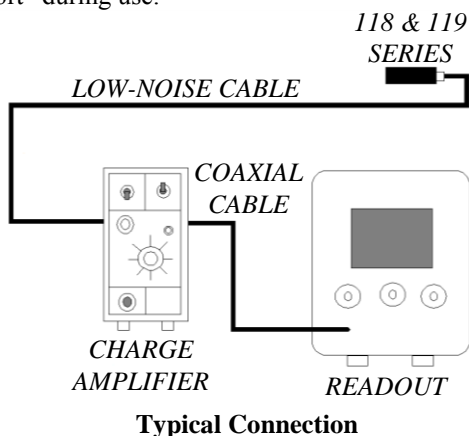

## 6.0 POLARITY

Since most charge amplifiers are inverting the input signal, 118 & 119 Series are designed to produce a negative output voltage for increasing pressure at the diaphragm.

Special positive output versions are available for use with our non-inverting ICP<sup>®</sup> source follower amplifiers.

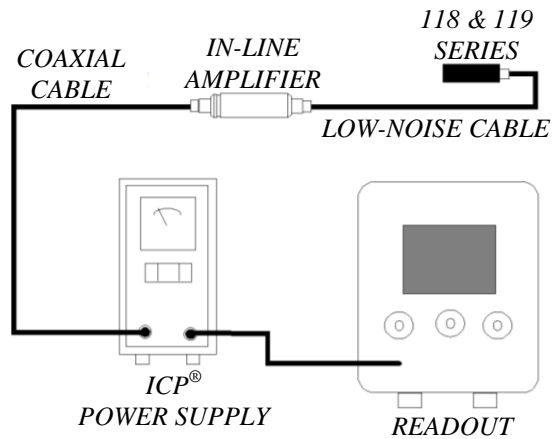

## 7.0 MAINTENANCE

Regular inspection of the diaphragm, threads, and connector of the 118 & 119 Series sensors is good practice.

During use in damp environments or after a period of storage, the insulation resistance of these sensors may degrade ( $10^{12}$  ohms is normal). The only maintenance required on the 118 & 119 Series is cleaning of the connector to restore insulation resistance.

To restore insulation resistance, wipe the connector end with a clean cloth or paper towel dipped in Lenium<sup>®</sup> or an equivalent solvent, then rinse in isopropyl alcohol. The sensor should then be placed in a 250°F (120°C) oven for several hours. A vacuum oven, if available, will speed the process.

Contact the factory for further assistance if the insulation resistance cannot be restored.

Model Number

119B11

## CHARGE OUTPUT PRESSURE SENSOR

Revision: D

ECN #: 27048

**Performance**

	<b>ENGLISH</b>	<b>SI</b>
Sensitivity(± 15 %)	0.25 pC/psi	0.036 pC/kPa
Measurement Range	0 to 80,000 psi	0 to 552,000 kPa
Maximum Pressure	100 kpsi	690,000 kPa
Resolution	≤ 1 psi	≤ 7 kPa
Resonant Frequency	≥ 400 kHz	≥ 400 kHz
Rise Time(Reflected)	≤ 2 μ sec	≤ 2 μ sec
Non-Linearity	≤ 2 % FS	≤ 2 % FS

**Environmental**

Acceleration Sensitivity	≤ 0.02 psi/g	≤ 0.015 kPa/(m/s <sup>2</sup> )
Temperature Range(Operating)	-300 to 400 °F	-184 to 204 °C
Temperature Coefficient of Sensitivity	≤ 0.07 %/°F	≤ 0.126 %/°C
Maximum Flash Temperature	4000 °F	2204 °C
Maximum Vibration	2000 g pk	19,614 m/s <sup>2</sup> pk
Maximum Shock	50,000 g pk	490,330 m/s <sup>2</sup> pk

**Electrical**

Output Polarity(Positive Pressure)	Negative	Negative
Capacitance	20 pF	20 pF
Insulation Resistance(at room temp)	≥ 1E12 ohm	≥ 1E12 ohm

**Physical**

Sensing Element	Quartz	Quartz
Housing Material	C-300	C-300
Diaphragm	C-300	C-300
Sealing	Epoxy	Epoxy
Electrical Connector	10-32 Coaxial Jack	10-32 Coaxial Jack
Weight	.5 oz	14 gm

All specifications are at room temperature unless otherwise specified.

In the interest of constant product improvement, we reserve the right to change specifications without notice.

ICP® is a registered trademark of PCB Group, Inc.

**OPTIONAL VERSIONS**

Optional versions have identical specifications and accessories as listed for the standard model except where noted below. More than one option may be used.

<b>H</b> - Hermetic Seal		
Housing Material	17-4 Stainless Steel	17-4 Stainless Steel
Maximum Shock	20,000 g pk	196,200
Sealing	Welded Hermetic	Welded Hermetic

**M** - Metric Mount**P** - Positive Output Polarity**W** - Water Resistant Cable**NOTES:**

- [1] Nominal.  
 [2] Zero-based, least-squares, straight line method.  
 [3] Ceramic coated.

**SUPPLIED ACCESSORIES:**

Model 065A06 Seal ring 0.318" OD x 0.250" ID x 0.010" thk 316L SS material (3)

Entered: BLS	Engineer: RF	Sales: DPC	Approved: RF	Spec Number:
Date: 8-11-07	Date: 8-7-07	Date: 8-7-07	Date: 8-7-07	20687

**PCB PIEZOTRONICS™**  
 PRESSURE DIVISION  
 3425 Walden Avenue, Depew, NY 14043

Phone: 716-684-0001  
 Fax: 716-686-9129  
 E-Mail: pressure@pcb.com

PCB Piezotronics Inc. claims proprietary rights in the information disclosed hereon. Neither it nor any reproduction thereof will be disclosed to others without the written consent of PCB Piezotronics Inc.

23503

REVISIONS		
REV	DESCRIPTION	DIN
C	UPDATED NOTE 2	37802

ELECTRICAL CONNECTOR  
COAXIAL 10-32 UNF-2A

RETAINING RING

MODEL 060A23  
CAPTIVATED FLOATING  
CLAMP NUT  
8.00 [.315] HEX  
MATERIAL: ST STL

M10 X 1-6g

MODEL 082A10 SEAL  
X .46 [.018] THICK  
MATERIAL: ST STL

MODEL 065A06 SEAL  
X .25 [.010] THICK  
MATERIAL: ST STL

Ø6.30 - 6.32  
[.248 - .249]

6.30 - 6.35  
[.248 - .250]

Ø 6.22 - 6.25  
[.245 - .246]

Ø8.10 - 8.13  
[.319 - .320]

43.3  
[1.71]

24.2  
[.95]

13.3  
[.52]

.89 - 1.02  
[.035 - .040]

### FLUSH INSTALLATION

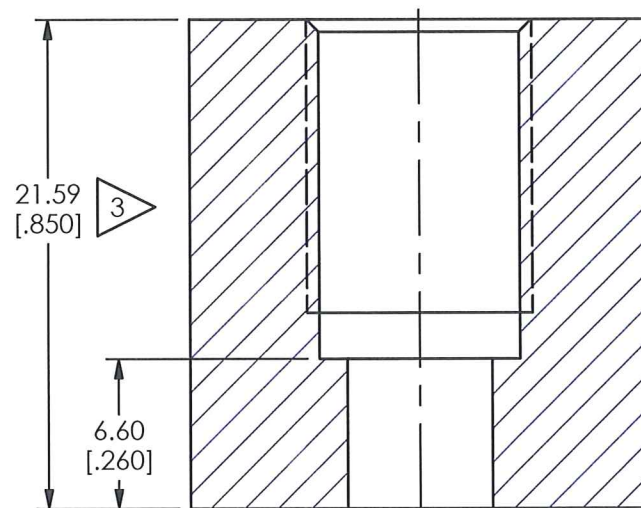

#### MOUNTING HOLE DIMENSIONS

- 3 5 Ø6.40 ± .03 [.252 ± .001] THRU
- 4 5 □ Ø9.10 [.358] (▽ 14.99 [.590])
- 8 M10 X 1.0-6H ▽2.95 [.510]

### RECESSED INSTALLATION

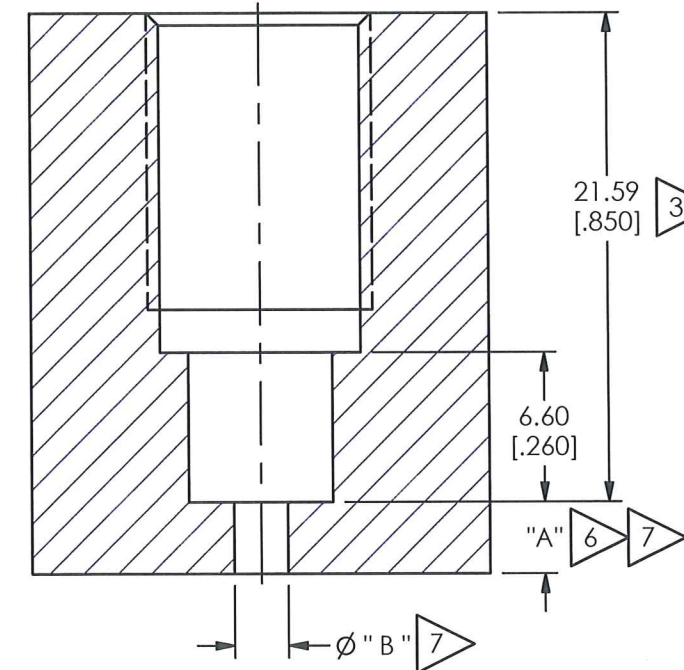

#### MOUNTING HOLE DIMENSIONS

- 3 5 □ Ø6.40 ± .03 [.252 ± .001] ▽ 21.59 [.850]
- 4 5 □ Ø9.10 [.358] (▽ 14.99 [.590])
- 8 M10 X 1.0-6H ▽2.95 [.510]

- 8 CAUTION: DO NOT TOUCH SEAL SURFACE WITH TAP WHEN TAPPING HOLE.
- 7 DIMENSIONS "A" AND "B" TO SUIT USER REQUIREMENTS.
- 6 KEEP DIMENSION "A" AS SHORT AS POSSIBLE, SEE OPERATING GUIDE FOR OPTIMUM PASSAGE LENGTH.
- 5 THESE DIAMETERS TO BE CONCENTRIC TO WITHIN 0.03 [.001] TIR.
- 4 SEAL SURFACE SHOULD BE FLAT AND FREE OF TOOL MARKS WITH A MINIMUM 1.6 [63] FINISH FOR BEST RESULTS.
- 3 DIMENSIONS SHOWN ARE FOR 21.59 [.850] THICK WALL. COUNTERBORE FOR THICKER WALLS.
- 2 RECOMMENDED MOUNTING TORQUE ON 8.00 [.315] HEX: 36-43 N-M [27-32 FT-LB].
- 1 MATERIAL: C-300 MARAGING STEEL.

UNLESS OTHERWISE SPECIFIED TOLERANCES ARE:		DRAWN	CHECKED	ENGINEER	
DIMENSIONS IN INCHES	DIMENSIONS IN MILLIMETERS [IN BRACKETS]	JDM	12/6/11	NJL	12/6/11
DECIMALS XX ±.01 XXX ±.005	DECIMALS X ±0.3 XX ±0.13	TITLE			
ANGLES ± 2 DEGREES	ANGLES ± 2 DEGREES	INSTALLATION DRAWING MODEL M119B11 & M119B12 PRESSURE SENSOR			
FILLETS AND RADII .003 - .005	FILLETS AND RADII 0.07 - 0.13	CODE IDENT. NO. 52681		DWG. NO. 23503	
		SCALE: 3X		SHEET 1 OF 1	

**PCB PIEZOTRONICS**  
3425 WALDEN AVE. DEPEW, NY 14043  
(716) 684-0001 E-MAIL: sales@pcb.com