



Model 102A02

High resolution ICP® pressure sensor, 100 psi, 50 mV/psi, 3/8-24 mtg thd with Jamb Nut, accel. comp., ground isolated

Installation and Operating Manual

**For assistance with the operation of this product,
contact the PCB Piezotronics, Inc.**

**Toll-free: 716-684-0001
24-hour SensorLine: 716-684-0001
Fax: 716-684-0987
E-mail: info@pcb.com
Web: www.pcb.com**



Repair and Maintenance

PCB guarantees Total Customer Satisfaction through its “Lifetime Warranty Plus” on all Platinum Stock Products sold by PCB and through its limited warranties on all other PCB Stock, Standard and Special products. Due to the sophisticated nature of our sensors and associated instrumentation, **field servicing and repair is not recommended and, if attempted, will void the factory warranty.**

Beyond routine calibration and battery replacements where applicable, our products require no user maintenance. Clean electrical connectors, housings, and mounting surfaces with solutions and techniques that will not harm the material of construction. Observe caution when using liquids near devices that are not hermetically sealed. Such devices should only be wiped with a dampened cloth—never saturated or submerged.

In the event that equipment becomes damaged or ceases to operate, our Application Engineers are here to support your troubleshooting efforts 24 hours a day, 7 days a week. Call or email with model and serial number as well as a brief description of the problem.

Calibration

Routine calibration of sensors and associated instrumentation is necessary to maintain measurement accuracy. We recommend calibrating on an annual basis, after exposure to any extreme environmental influence, or prior to any critical test.

PCB Piezotronics is an ISO-9001 certified company whose calibration services are accredited by A2LA to ISO/IEC 17025, with full traceability to SI through N.I.S.T. In addition to our standard calibration services, we also offer specialized tests, including: sensitivity at elevated or cryogenic temperatures, phase response, extended high or low frequency response, extended range, leak testing, hydrostatic pressure testing, and others. For more information, contact your local PCB Piezotronics distributor, sales representative, or factory customer service representative.

Returning Equipment

If factory repair is required, our representatives will provide you with a Return Material Authorization (RMA) number, which we use to reference any information you have already provided and expedite the repair process. This number should be clearly marked on the outside of all returned package(s) and on any packing list(s) accompanying the shipment.

Contact Information

PCB Piezotronics, Inc.
3425 Walden Ave.
Depew, NY14043 USA
Toll-free: (800) 828-8840
24-hour SensorLine: (716) 684-0001
General inquiries: info@pcb.com
Repair inquiries: rma@pcb.com

For a complete list of distributors, global offices and sales representatives, visit our website, www.pcb.com.

Safety Considerations

This product is intended for use by qualified personnel who recognize shock hazards and are familiar with the precautions required to avoid injury. While our equipment is designed with user safety in mind, the protection provided by the equipment may be impaired if equipment is used in a manner not specified by this manual.

Discontinue use and contact our 24-Hour Sensorline if:

- Assistance is needed to safely operate equipment
- Damage is visible or suspected
- Equipment fails or malfunctions

For complete equipment ratings, refer to the enclosed specification sheet for your product.

Definition of Terms and Symbols

The following symbols may be used in this manual:



DANGER

Indicates an immediate hazardous situation, which, if not avoided, may result in death or serious injury.

**CAUTION**

Refers to hazards that could damage the instrument.

**NOTE**

Indicates tips, recommendations and important information. The notes simplify processes and contain additional information on particular operating steps.

The following symbols may be found on the equipment described in this manual:



This symbol on the unit indicates that high voltage may be present. Use standard safety precautions to avoid personal contact with this voltage.



This symbol on the unit indicates that the user should refer to the operating instructions located in the manual.



This symbol indicates safety, earth ground.



PCB工业监视和测量设备 - 中国RoHS2公布表

PCB Industrial Monitoring and Measuring Equipment - China RoHS 2 Disclosure Table

部件名称	有害物质					
	铅 (Pb)	汞 (Hg)	镉 (Cd)	六价铬 (Cr(VI))	多溴联苯 (PBB)	多溴二苯醚 (PBDE)
住房	0	0	0	0	0	0
PCB板	X	0	0	0	0	0
电气连接器	0	0	0	0	0	0
压电晶体	X	0	0	0	0	0
环氧	0	0	0	0	0	0
铁氟龙	0	0	0	0	0	0
电子	0	0	0	0	0	0
厚膜基板	0	0	X	0	0	0
电线	0	0	0	0	0	0
电缆	X	0	0	0	0	0
塑料	0	0	0	0	0	0
焊接	X	0	0	0	0	0
铜合金/黄铜	X	0	0	0	0	0
本表格依据 SJ/T 11364 的规定编制。						
0：表示该有害物质在该部件所有均质材料中的含量均在 GB/T 26572 规定的限量要求以下。						
X：表示该有害物质至少在该部件的某一均质材料中的含量超出 GB/T 26572 规定的限量要求。						
铅是欧洲RoHS指令2011/65/ EU附件三和附件四目前由于允许的豁免。						

CHINA RoHS COMPLIANCE

Component Name	Hazardous Substances					
	Lead (Pb)	Mercury (Hg)	Cadmium (Cd)	Chromium VI Compounds (Cr(VI))	Polybrominated Biphenyls (PBB)	Polybrominated Diphenyl Ethers (PBDE)
Housing	O	O	O	O	O	O
PCB Board	X	O	O	O	O	O
Electrical Connectors	O	O	O	O	O	O
Piezoelectric Crystals	X	O	O	O	O	O
Epoxy	O	O	O	O	O	O
Teflon	O	O	O	O	O	O
Electronics	O	O	O	O	O	O
Thick Film Substrate	O	O	X	O	O	O
Wires	O	O	O	O	O	O
Cables	X	O	O	O	O	O
Plastic	O	O	O	O	O	O
Solder	X	O	O	O	O	O
Copper Alloy/Brass	X	O	O	O	O	O

This table is prepared in accordance with the provisions of SJ/T 11364.

O: Indicates that said hazardous substance contained in all of the homogeneous materials for this part is below the limit requirement of GB/T 26572.

X: Indicates that said hazardous substance contained in at least one of the homogeneous materials for this part is above the limit requirement of GB/T 26572.

Lead is present due to allowed exemption in Annex III or Annex IV of the European RoHS Directive 2011/65/EU.

**OPERATION MANUAL FOR
ICP® PRESSURE SENSORS
Models 102A02, A05, A07, A09
Models 112A21, A22, A23**

1.0 INTRODUCTION

The series of miniature pressure sensors described by this operating guide is designed for low pressure, high resolution applications and features acceleration compensation.

Uses include monitoring of low pressure hydraulic and pneumatic phenomena in the presence of shock and vibration such as on jet engines, compressors, turbines and other operating machinery, high intensity sound and turbulence measurements, and many other industrial R & D applications.

2.0 DESCRIPTION

This series is comprised of six sensor models having high sensitivities, but differing in mechanical configuration.

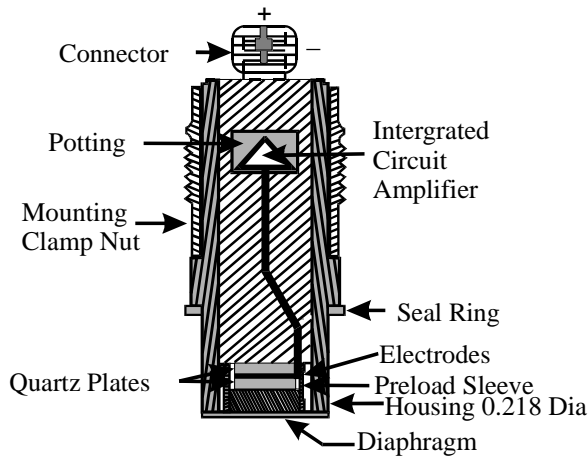

Each model utilizes the basic ICP® pressure probe as shown in above figure. The pressure probe consists of the Model 112A high sensitivity acceleration-compensated quartz element and an IC source follower amplifier joined together as an inseparable assembly.

Refer to "General Guide to ICP® Instrumentation" G-0001B for a complete treatment of the ICP® concept.

Models 112A21, 112A22 and 112A23 are in the basic probe configuration as shown in Figure 1, and are installed with a hollow clamp nut with 5/16-24 external threads. The housings of these models are at electrical ground potential.

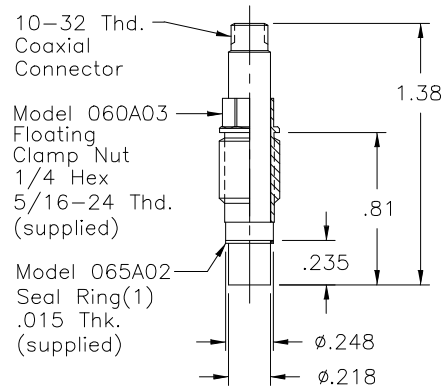

Series 111: Probe Style Sensor

The Model 102A05 utilizes the same basic pressure probe, mounted in a 3/8-24 threaded mounting adaptor with shoulder seal. The probe is assembled into the adaptor at the factory in an "off ground" configuration, i.e., the probe body is electrically insulated from the external mounting adaptor body. Do not attempt to disassemble probe and adaptor.

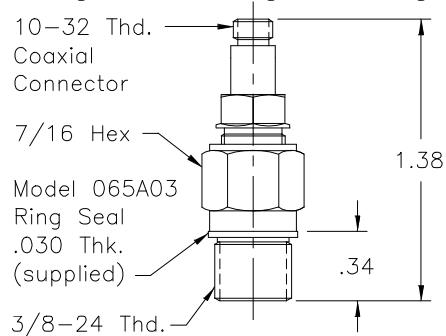

Model 102A05 Thread Mount Design, Ground-Isolated Sensor

**OPERATION MANUAL FOR
ICP® PRESSURE SENSORS
Models 102A02, A05, A07, A09
Models 112A21, A22, A23**

Models 102A02, 102A07, and 102A09 utilize the same inner probe design but in a 3/8-24 threaded adaptor with floating clamp nut to allow adjustment of diaphragm depth where it is necessary to adapt to various wall thicknesses. These models are supplied only in low pressure (100 and 50 psi) versions and are also "off ground".

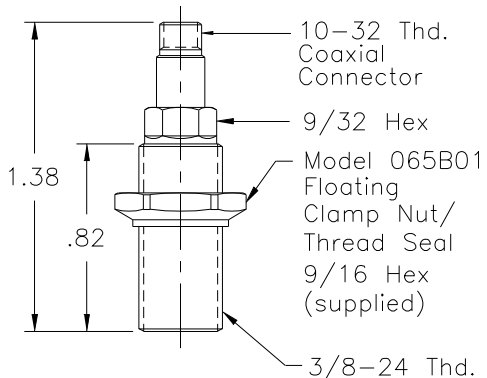

102A's: Thread Mount with Floating Clamp Nut, Ground-Isolated Sensor

3.0 INSTALLATION

This manual contains outline and installation information for your specific model in this series. Prepare mounting ports in accordance with the installation drawing for the specific model, paying particular attention to sealing surfaces. These surfaces must be smooth and free from chatter marks, nicks and other irregularities which could preclude a pressure-tight seal.

Seals are provided with each sensor and should always be used. Extra seals for all standard models are in stock at the factory. Replace seals when they become unserviceable.

In some cases, e.g., where flash temperatures such as those generated by combustion processes are present, it may be necessary to thermally insulate the diaphragm to minimize spurious signals generated by these effects.

Common black vinyl electrical tape has been found to be an effective insulating material in many cases. One or more layers may be used across the end of the diaphragm without affecting response or sensitivity.

A silicone rubber coating approximately .010" thick has also been proven effective in many applications. General Electric RTV type 106 silicone rubber is recommended. Apply the rubber coating and allow to cure in accordance with the manufacturer's instructions.

Although ICP® sensors have low output impedance and in general are not affected by moisture, in extreme environments it is good practice to protect cable connections with shrink tubing.

It is not necessary to use low-noise coaxial cable with this sensor series. In fact, a Model 070A09 solder connector adaptor that allows the use of ordinary two-wire cable is desired.

4.0 OPERATION

It is only necessary to supply the sensor with a 2 to 20 mA constant current at +20 to +30 VDC through a current-regulating diode or equivalent circuit. (See Guide G-0001B for powering and signal utilization information pertaining to all ICP® instrumentation).

Most of the signal conditioners manufactured by PCB have an adjustable current feature allowing a choice of input currents from 2 to 20 mA. In general, for lowest noise (best resolution) choose the low current ranges and for driving long cables (to several thousand feet) use the higher current, up to 20 mA maximum.

To operate system using a PCB signal conditioner:

1. Switch power on.
2. Wait several minutes for the IC amplifier to turn on and stabilize.
3. Proceed with measurements.

4.1 OPERATING CONSIDERATION FOR MODEL 112A23

The Model 112A23 features a low-noise amplifier which, based on a peak-to-peak broadband noise factor of 50 μ V, results in a resolution of .001 psi.

**OPERATION MANUAL FOR
ICP® PRESSURE SENSORS
Models 102A02, A05, A07, A09
Models 112A21, A22, A23**

Defined for practical purposes as the minimum readout signal, the resolution is based on the sensitivity of 50 mV/psi and a low noise amplifier of 50 μ V peak noise.

Thus, $50 \mu\text{V}/50\text{mV} = .001$ psi resolution

The output bias voltage of the Model 112A23 is 5.0 volts, half the bias voltage of most PCB pressure sensors. This will cause the bias monitor meter on PCB power supplies to read at the low end of the green band.

5.0 POLARITY

This sensor series produces a positive-going output voltage for increasing pressure input.

6.0 LOW FREQUENCY RESPONSE

The low frequency response of an ICP® system is determined by:

1. The discharge time constant of the sensor, and,
2. If AC-coupled at power unit, the coupling time constant.

Consult Section 7.0 in Guide G-0001B for detailed explanation of low frequency characteristics of ICP® instruments.

7.0 CALIBRATION

Piezoelectric sensors are dynamic devices, but static calibration methods may be employed if discharge time constants are sufficiently long. Generally, static methods are not employed below several hundred seconds discharge time constant.

To employ static methods, directly couple the sensor to the DVM readout using a T-connector from the XD4R jack or use the Model 484B in the "calibrate" mode. Apply pressure with dead weight tester and take readings quickly. Release pressure after each calibration point.

For the shorter discharge time constant series, a rapid pressure step must be generated by a pneumatic pressure pulse calibrator or dead weight tester and readout is by recorder or storage oscilloscope.

PCB offers a complete recalibration service. Consult factory for details.

**OPERATION MANUAL FOR
ICP® PRESSURE SENSORS
Models 102A02, A05, A07, A09
Models 112A21, A22, A23**

8.0 MAINTENANCE

The miniature size sealed construction precludes field maintenance. Should service be required, return unit to factory with note describing problem.

®ICP is a registered trademark of PCB Piezotronics

	ENGLISH	SI
Performance		
Measurement Range(for ±5V output)	100 psi	690 kPa
Useful Overrange(for ± 10V output)	200 psi	1,379 kPa
Sensitivity(± 20 %)	50 mV/psi	7.3 mV/kPa
Maximum Pressure(step)	1 kpsi	6,900 kPa
Maximum Pressure(Total)	15,000 psi	103,421 kPa
Resolution	0.4 mpsi	0.0028 kPa
Resonant Frequency	≥ 250 kHz	≥ 250 kHz
Rise Time(Reflected)	≤ 2.0 μ sec	≤ 2.0 μ sec
Low Frequency Response(- 5 %)	0.5 Hz	0.5 Hz
Non-Linearity	≤ 1.0 % FS	≤ 1.0 % FS
Environmental		
Acceleration Sensitivity	0.002 psi/g	0.0014 kPa/(m/s ²)
Temperature Range(Operating)	-100 to +275 °F	-73 to +135 °C
Temperature Coefficient of Sensitivity	≤ 0.03 %/°F	≤ 0.054 %/°C
Maximum Flash Temperature	3,000 °F	1,650 °C
Maximum Vibration	2,000 g pk	19,600 m/s ² pk
Maximum Shock	20,000 g pk	196,000 m/s ² pk
Electrical		
Output Polarity(Positive Pressure)	Positive	Positive
Discharge Time Constant(at room temp)	≥ 1.0 sec	≥ 1.0 sec
Excitation Voltage	20 to 30 VDC	20 to 30 VDC
Constant Current Excitation	2 to 20 mA	2 to 20 mA
Output Impedance	< 100 Ohm	< 100 Ohm
Output Bias Voltage	8 to 14 VDC	8 to 14 VDC
Electrical Isolation	≥ 10 ⁸ Ohm	≥ 10 ⁸ Ohm
Physical		
Sensing Geometry	Compression	Compression
Sensing Element	Quartz	Quartz
Housing Material	17-4 / 304L Stainless Steel	17-4 / 304L Stainless Steel
Thread Adaptor Material	17-4 Stainless Steel	17-4 Stainless Steel
Diaphragm	Invar	Invar
Sealing	Welded Hermetic	Welded Hermetic
Electrical Connector	10-32 Coaxial Jack	10-32 Coaxial Jack
Weight	0.39 oz	11.0 gm

OPTIONAL VERSIONS

Optional versions have identical specifications and accessories as listed for the standard model except where noted below. More than one option may be used.

CA - Ablative Coating

M - Metric Mount
Supplied Accessory: Model 065A42 Floating clamp nut and thread seal, M10 x 1.0 thd. (1) replaces Model 065B01

N - Negative Output Polarity

S - Stainless Steel Diaphragm

W - Water Resistant Cable

NOTES:

[1] For +10 volt output, minimum 24 VDC supply voltage required. Negative 10 volt output may be limited by output bias.

[2] Typical.

[3] Zero-based, least-squares, straight line method.

[4] See PCB Declaration of Conformance PS023 for details.

SUPPLIED ACCESSORIES:

Model 065B01 Floating clamp nut and thread seal 3/8-24 thd (1)
Model PCS-1AZ Sensitivity calibration at 100% and 10% of sensor range

Entered: ND	Engineer: AJA	Sales: RWM	Approved: RPF	Spec Number:
Date: 07/11/2024	Date: 07/11/2024	Date: 07/11/2024	Date: 07/11/2024	6371

PCB PIEZOTRONICS
AN AMPHENOL COMPANY

Phone: 716-684-0001
Fax: 716-684-0987
E-Mail: info@pcb.com

3425 Walden Avenue, Depew, NY 14043



All specifications are at room temperature unless otherwise specified.
In the interest of constant product improvement, we reserve the right to change specifications without notice.
ICP® is a registered trademark of PCB Piezotronics, Inc.

2

1

PCB Piezotronics Inc. claims proprietary rights in the information disclosed hereon. Neither it nor any reproduction thereof will be disclosed to others without the written consent of PCB Piezotronics Inc.

REVISIONS

REV	DESCRIPTION	DIN
B	UPDATED OVERALL LENGTH TOLERANCE	53183

8495

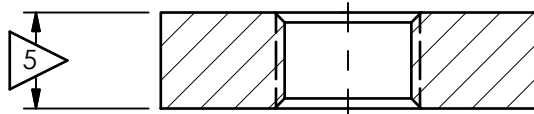
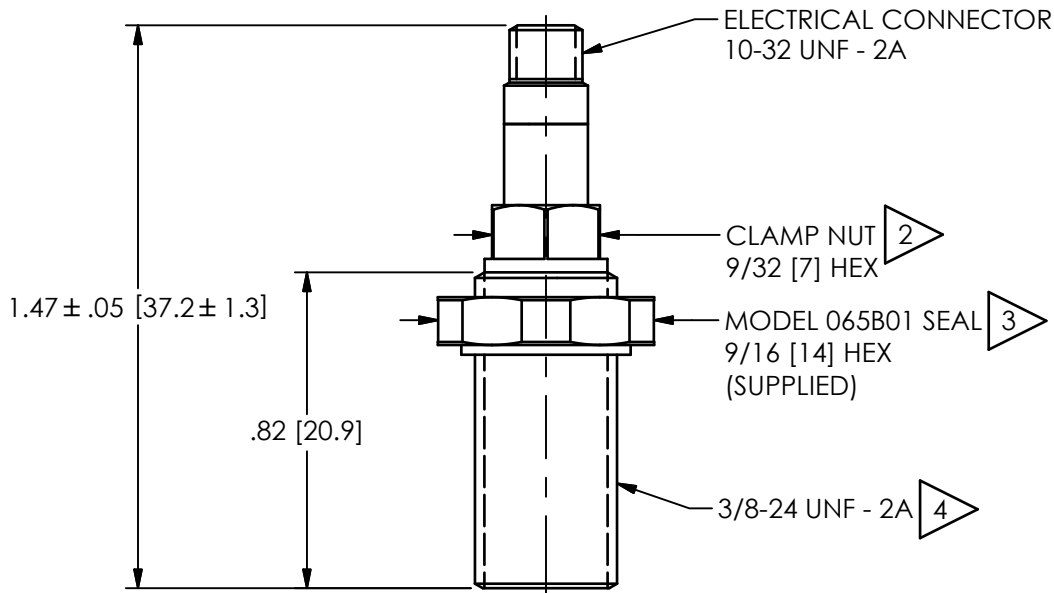

MOUNTING HOLE PREPARATION:

3/8-24 UNF - 2B THRU

5 LENGTH TO SUIT USER REQUIREMENTS

4 COAT THREADS OF SENSOR WITH PTFE THREAD SEALANT IF REQUIRED (FOR VACUUM TIGHT SEAL ONLY)

3 ADJUST MODEL 065B01 SEAL TO APPROXIMATE POSITION REQUIRED

2 USE 9/32 [7] NUT DRIVER TO TURN SENSOR INTO TAPPED HOLE. NORMAL LOCATION OF DIAPHRAGM FACE IS FLUSH WITH INSIDE SURFACE. RECESS .010 [.25] FOR ABLATIVE COATING IF DESIRED. WHILE HOLDING SENSOR WITH NUT DRIVER, TIGHTEN SEAL TO OBTAIN PRESSURE-TIGHT SEAL AND LOCK SENSOR IN PLACE. RECOMMENDED MOUNTING TORQUE 20-25 IN-LBS [226-282 N-cm]

1.) THIS SENSOR IS A SEALED ASSEMBLY AND MUST BE RETURNED TO THE FACTORY SHOULD SERVICE BECOME NECESSARY

UNLESS OTHERWISE SPECIFIED TOLERANCES ARE:

DRAWN		CHECKED		ENGINEER	
NJF	10/04/22	JDM	10/04/22	AJA	10/04/22

PCB PIEZOTRONICS
AN AMPHENOL COMPANY

3425 WALDEN AVE. DEPEW, NY 14043
(716) 684-0001 E-MAIL: sales@pcb.com

DIMENSIONS IN INCHES	
DECIMALS XX ± .01	XXX ± .005
ANGLES ± 2 DEGREES	

DIMENSIONS IN MILLIMETERS [IN BRACKETS]	
DECIMALS X ± 0.3	XX ± 0.13
ANGLES ± 2 DEGREES	

CABLE TOLERANCES IN ENGLISH	
1" ≤ LENGTH < 1'	= +1" / - 0
1' ≤ LENGTH < 5'	= +2" / - 0
5' ≤ LENGTH < 100'	= +6" / - 0
100' ≤ LENGTH	= +1' / - 0

CABLE TOLERANCES IN METRIC	
2.54cm ≤ LENGTH < 30.5cm	= +2.54cm / - 0
30.5cm ≤ LENGTH < 1.5m	= +5.1cm / - 0
1.5m ≤ LENGTH < 30.5m	= +15.2cm / - 0
30.5m ≤ LENGTH	= +30.5cm / - 0

TITLE
INSTALLATION DRAWING
MODEL 101A & 102A02, A07, A09, A12
PRESSURE SENSORS

CODE IDENT. NO. 52681	DWG. NO. 8495
-----------------------	---------------

SCALE: 2X	SHEET 1 OF 1
-----------	--------------

2

1