



Model 686B1X/-0012

Smart Vibration Switch

Installation and Operating Manual

**For assistance with the operation of this product,
contact the PCB Piezotronics, Inc.**

Toll-free: 800-959-4464

24-hour SensorLine: 716-684-0001

Fax: 716-684-3823

E-mail: imi@pcb.com

Web: www.imi-sensors.com





Service, Repair, and Return Policies and Instructions
--

The information contained in this document supersedes all similar information that may be found elsewhere in this manual.

Service – Due to the sophisticated nature of the sensors and associated instrumentation provided by PCB Piezotronics, user servicing or repair is not recommended and, if attempted, may void the factory warranty. Routine maintenance, such as the cleaning of electrical connectors, housings, and mounting surfaces with solutions and techniques that will not harm the physical material of construction, is acceptable. Caution should be observed to ensure that liquids are not permitted to migrate into devices that are not hermetically sealed. Such devices should only be wiped with a dampened cloth and never submerged or have liquids poured upon them.

Repair – In the event that equipment becomes damaged or ceases to operate, arrangements should be made to return the equipment to PCB Piezotronics for repair. User servicing or repair is not recommended and, if attempted, may void the factory warranty.

Calibration – Routine calibration of sensors and associated instrumentation is recommended as this helps build confidence in measurement accuracy and acquired data. Equipment calibration cycles are typically established by the users own quality regimen. When in doubt about a calibration cycle, a good “rule of thumb” is to recalibrate on an annual basis. It is

also good practice to recalibrate after exposure to any severe temperature extreme, shock, load, or other environmental influence, or prior to any critical test.

PCB Piezotronics maintains an ISO-9001 certified metrology laboratory and offers calibration services, which are accredited by A2LA to ISO/IEC 17025, with full traceability to SI through N.I.S.T. In addition to the normally supplied calibration, special testing is also available, such as: sensitivity at elevated or cryogenic temperatures, phase response, extended high or low frequency response, extended range, leak testing, hydrostatic pressure testing, and others. For information on standard recalibration services or special testing, contact your local PCB Piezotronics distributor, sales representative, or factory customer service representative.

Returning Equipment – *Following these procedures will ensure that your returned materials are handled in the most expedient manner.* Before returning any equipment to PCB Piezotronics, contact your local distributor, sales representative, or factory customer service representative to obtain a Return **Warranty, Service, Repair, and Return Policies and Instructions** Materials Authorization (RMA) Number. This RMA number should be clearly marked on the outside of all package(s) and on the packing

list(s) accompanying the shipment. A detailed account of the nature of the problem(s) being experienced with the equipment should also be included inside the package(s) containing any returned materials.

A Purchase Order, included with the returned materials, will expedite the turn-around of serviced equipment. It is recommended to include authorization on the Purchase Order for PCB to proceed with any repairs, as long as they do not exceed 50% of the replacement cost of the returned item(s). PCB will provide a price quotation or replacement recommendation for any item whose repair costs would exceed 50% of replacement cost, or any item that is not economically feasible to repair. For routine calibration services, the Purchase Order should include authorization to proceed and return at current pricing, which can be obtained from a factory customer service representative.

Contact Information – International customers should direct all inquiries to their local distributor or sales office. A

complete list of distributors and offices can be found at www.pcb.com. Customers within the United States may contact their local sales representative or a factory customer service representative. A complete list of sales representatives can be found at www.pcb.com. Toll-free telephone numbers for a factory customer service representative, in the division responsible for this product, can be found on the title page at the front of this manual. Our ship to address and general contact numbers are:

PCB Piezotronics, Inc.
3425 Walden Ave.
Depew, NY14043 USA
Toll-free: (800) 828-8840
24-hour SensorLineSM: (716) 684-0001
Website: www.pcb.com
E-mail: info@pcb.com



PCB工业监视和测量设备 - 中国RoHS2公布表
 PCB Industrial Monitoring and Measuring Equipment - China RoHS 2 Disclosure Table

部件名称	有害物质					
	铅 (Pb)	汞 (Hg)	镉 (Cd)	六价铬 (Cr(VI))	多溴联苯 (PBB)	多溴二苯醚 (PBDE)
住房	○	○	○	○	○	○
PCB板	X	○	○	○	○	○
电气连接器	○	○	○	○	○	○
压电晶体	X	○	○	○	○	○
环氧	○	○	○	○	○	○
铁氟龙	○	○	○	○	○	○
电子	○	○	○	○	○	○
厚膜基板	○	○	X	○	○	○
电线	○	○	○	○	○	○
电缆	X	○	○	○	○	○
塑料	○	○	○	○	○	○
焊接	X	○	○	○	○	○
铜合金/黄铜	X	○	○	○	○	○
本表格依据 SJ/T 11364 的规定编制。						
○：表示该有害物质在该部件所有均质材料中的含量均在 GB/T 26572 规定的限量要求以下。						
X：表示该有害物质至少在该部件的某一均质材料中的含量超出 GB/T 26572 规定的限量要求。						
铅是欧洲RoHS指令2011/65/ EU附件三和附件四目前由于允许的豁免。						

CHINA RoHS COMPLIANCE

Component Name	Hazardous Substances					
	Lead (Pb)	Mercury (Hg)	Cadmium (Cd)	Chromium VI Compounds (Cr(VI))	Polybrominated Biphenyls (PBB)	Polybrominated Diphenyl Ethers (PBDE)
Housing	O	O	O	O	O	O
PCB Board	X	O	O	O	O	O
Electrical Connectors	O	O	O	O	O	O
Piezoelectric Crystals	X	O	O	O	O	O
Epoxy	O	O	O	O	O	O
Teflon	O	O	O	O	O	O
Electronics	O	O	O	O	O	O
Thick Film Substrate	O	O	X	O	O	O
Wires	O	O	O	O	O	O
Cables	X	O	O	O	O	O
Plastic	O	O	O	O	O	O
Solder	X	O	O	O	O	O
Copper Alloy/Brass	X	O	O	O	O	O

This table is prepared in accordance with the provisions of SJ/T 11364.

O: Indicates that said hazardous substance contained in all of the homogeneous materials for this part is below the limit requirement of GB/T 26572.

X: Indicates that said hazardous substance contained in at least one of the homogeneous materials for this part is above the limit requirement of GB/T 26572.

Lead is present due to allowed exemption in Annex III or Annex IV of the European RoHS Directive 2011/65/EU.

DOCUMENT NUMBER: 21354

DOCUMENT REVISION: **D**

ECN: 46162



Operating Guide with Enclosed Warranty Information

3425 Walden Avenue, Depew, New York 14043-2495

Phone (716) 684-0003

Fax (716) 684-3823

Toll Free Line 1-800-959-4IMI

MANUAL NUMBER: 40112

MANUAL REVISION: **G**

ECO: **49766**

Table of Contents

Introduction	Page 3
General Features	
Operating Principles	Page 4
Benefits of Solid State Relays	
Installation.....	Page 5
Direct Adhesive Mount	
Standard Stud Mount	
Adhesive Stud Mount	
Magnetic Mount	
Wiring.....	Page 9
Legend	
Indicating a High Level of Vibration in a Motor	
Indicating High Levels of Vibration Simultaneously in Series (Such as Fan & Motor)	
Constant Siren Alarming in the Event of High Vibration Levels	
Two Switches in Parallel to Monitor Two Axes Simultaneously on Same Motor	
Three Switches in Parallel to Monitor Three Motors Simultaneously	
Automatic Machinery Shutdown Using an External Electromechanical Relay	
Automatic Machinery Shutdown Using External Electromechanical Relay While Monitoring 2 Axes	
Switch and External Latching for Automatic Machinery Shutdown	
Both Alarm Siren and Automatic Machinery Shutdown Using Two Switches	
Automatic Machinery Shutdown Based on Normally Open Solid State Relay	
Automatic Machinery Shutdown of a Three Phase Electrical Motor Based on a N.O. Solid-State Relay	
Programming Software	Page 21
Program Installation	
Running the Software	
Programming Sections	
Reading and Writing Parameters	
Parameter Options	
Execution of Delays	
Magnetically Adjustable Vibration Threshold (MAVT™)	Page 29
MAVT™ Procedure	
Factory-Programmed Ordering Guide	Page 30
Battery-Powered Signal Conditioner	Page 31
Calibration Cable	Page 31
Magnet Clip.....	Page 31
Cable Ordering Information	Page 32
ESD Sensitivity	Page 33
Warranty, Service & Return Procedure	Page 34
Customer Service	Page 34

Introduction

The 686-Series Smart Vibration Switch is a low-cost electronic vibration switch designed to monitor vibration levels on rotating machinery (ie. fans and cooling towers) and trip an alarm or shut down machinery when a specified vibration limit is exceeded. An onboard accelerometer with precision, microprocessor-controlled electronics ensures reliable operation and accuracy. The switch contains a two-pin MIL connector for easy drop-in replacement of mechanical vibration switches and a reliable solid state relay. Multiple units can be installed in a loop configuration for economical installation and expanded protection of critical machinery. This versatile switch can be used to replace more expensive electronic vibration switches where separate vibration output is not required and to replace troublesome mechanical vibration switches.

Every Smart Switch is factory-programmed. See Page 28 for more information.

General Features

- Fully USB-programmable from any PC (with optional USB Programmer Kit).
- Hermetically-sealed, stainless steel housing for use in corrosive environments.
- Imbedded piezoelectric accelerometer for improved accuracy and frequency response.
- Small footprint and single ¼-28 stud mounting.
- Solid state (AC/DC) relay.
- Universal AC or DC power.
- Magnetically Adjustable Vibration Threshold (MAVT™).
- Connects with industry standard MIL-C-5015 connector or integral cable.
- Programmable features
 - Alarm threshold level
 - Normally Open (NO) or Normally Closed (NC) relay
 - Latching or non-latching relay
 - Delays
 - Power on
 - Startup
 - Operational
 - Residual vibration level
- Intrinsically-safe versions available (EX prefix)
 - CSA

Operating Principles

The Smart Switch operates over just two wires. It installs in series with any load (ie. annunciator, PLC or relay coil). To energize itself, the vibration switch scavenges power from the load's power source. When the alarm threshold is exceeded, the switch is activated and the load's power circuit is completed to facilitate the desired alarm or shutdown.

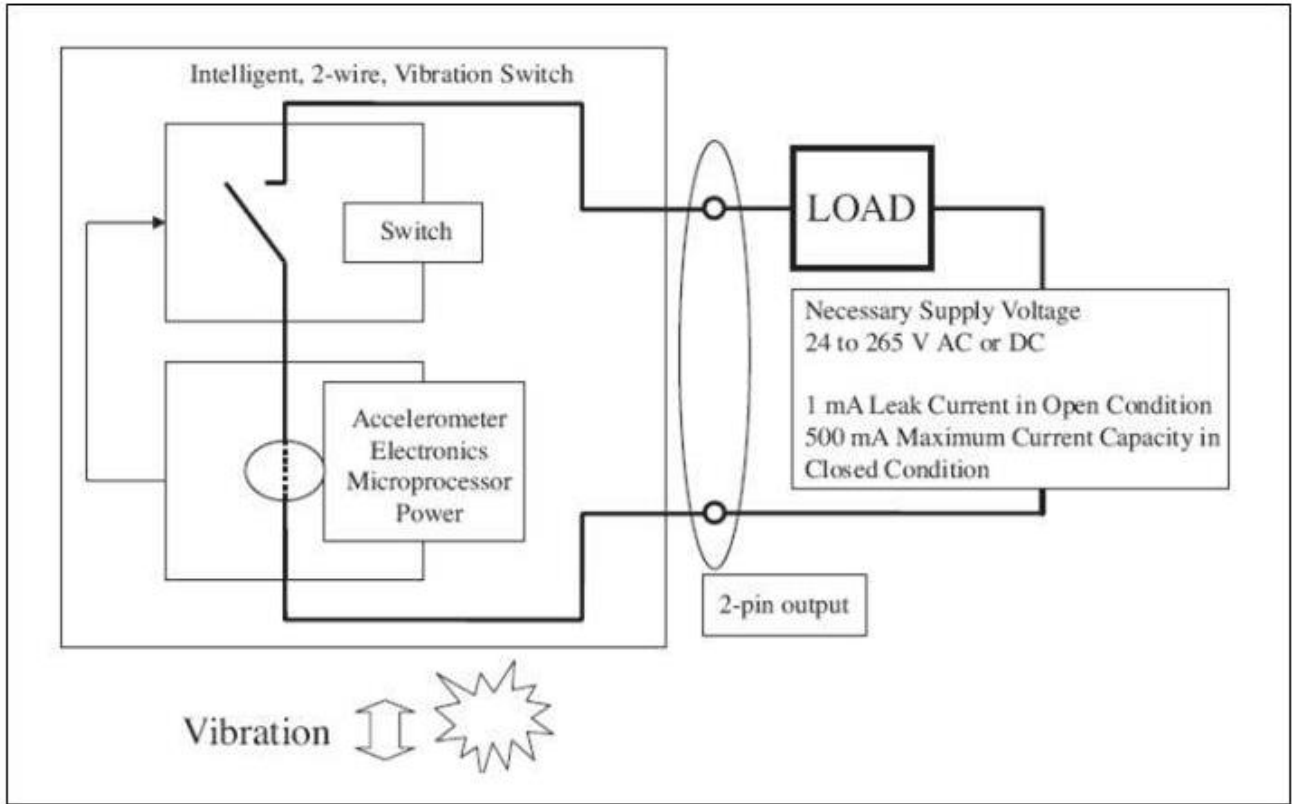

Figure 1 – Block Diagram

Benefits of Solid State Relays

A solid state relay is an electronic component that functions in the same way as an electromechanical relay, but without any moving parts. A solid state relay offers the most reliable switch action, especially for vibration applications where moving relay components run a greater risk of malfunction. They are purely electronic devices composed of a low current control side and a high current load side for switching action.

Installation

When choosing a mounting method, consider closely the advantages and disadvantages of each technique. Typical mounting types are stud, direct adhesive, adhesive mounting base and magnetic mounting base.

Note: For a complete list of product specifications, see the “Specification Sheet” and “Outline Drawing” at the end of this Manual.

Direct Adhesive Mount Procedure

For restrictions of space or for convenience, most sensors (with the exception of integral stud models) can be adhesive-mounted directly to the machine surface.

- Step 1: Prepare a smooth, flat mounting surface. A minimum surface finish of 63 μin (0.0016 mm) generally works best.
- Step 2: Place a small portion of adhesive on the underside of the sensor. Firmly press down on the top of the assembly to displace any adhesive. Be aware that excessive amounts of adhesive can make sensor removal difficult.

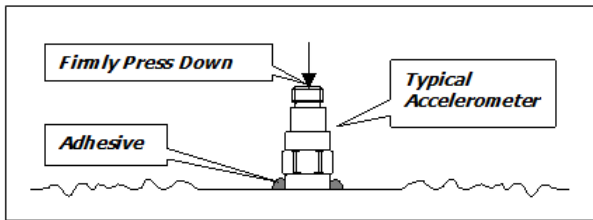

Figure 2 – Direct Adhesive Mounting

Standard Stud Mount Procedure

This mounting technique requires smooth, flat contact surfaces for proper operation and is recommended for permanent and/or secure installations. Stud mounting is also recommended when testing at high frequencies.

Note: Do not attempt mounting on curved, rough or uneven surfaces, as the potential for misalignment and limited contact surface may significantly reduce the sensor's upper operating frequency range.

	¼-28 Stud	¼-28 Captive Screw
A (in)	0.250	0.250
B (in)	0.350	0.350
Torque (ft-lb)	2 to 5	2 to 5

- Step 1: First, prepare a smooth, flat mounting surface and then drill and tap a mounting hole in the center of this area. A precision-machined mounting surface with a minimum finish of 63 µin (0.0016 mm) is recommended. (If it is not possible to properly prepare the machine surface, consider using an adhesive mounting pad as a possible alternative.) Inspect the area, checking that there are no burrs or other foreign particles interfering with the contact surface.
- Step 2: Wipe clean the mounting surface and spread on a light film of grease, oil or similar coupling fluid prior to installation. Adding a coupling fluid improves vibration transmissibility by filling small voids in the mounting surface and increasing the mounting stiffness. For semi-permanent mounting, substitute epoxy or another type of adhesive.
- Step 3: Hand-tighten the sensor/mounting stud to the machine, and then secure the sensor with a torque wrench to the mounting surface by applying the recommended mounting torque (see enclosed specification data sheet for proper mounting torque). It is important to use a torque wrench during this step. Under-torquing the sensor may not adequately couple the device; over-torquing may result in stud failure and possibly permanent damage.

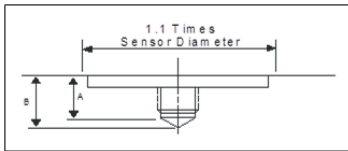

Figure 3 – Mounting Surface Preparation

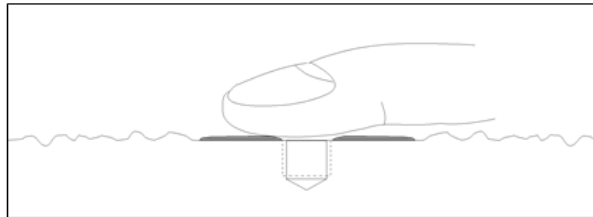

Figure 4 – Mounting Surface Lubrication

Adhesive Stud Mount Procedure

Adhesive mounting is often used for temporary installation or when the machine surface cannot be adequately prepared for stud mounting. Adhesives like hot glue or wax work well for temporary mounts; two-part epoxies and quick-bonding gels provide a more permanent mount.

Note: Adhesively mounted sensors often exhibit a reduction in high-frequency range. Generally, smooth surfaces and stiff adhesives provide the best frequency response. Contact the factory for recommended epoxies.

This method involves attaching a base to the machine surface, then securing the sensor to the base. This allows for easy removal of the accelerometer.

- Step 1: Prepare a smooth, flat mounting surface. A minimum surface finish of 63 μin (0.0016 mm) generally works best.
- Step 2: Stud-mount the sensor to the appropriate adhesive mounting base according to the guidelines set forth in Steps 2 and 3 of the Standard Stud Mount Procedure.
- Step 3: Place a small portion of adhesive on the underside of the mounting base. Firmly press down on the assembly to displace any extra adhesive remaining under the base.

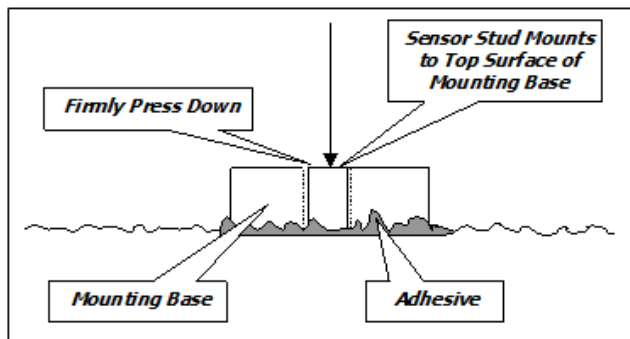

Figure 5 – Adhesive Installation of Mounting Base

Magnetic Mount Procedure

Magnetic mounting provides a convenient means for making portable measurements and is commonly used for machinery monitoring and other portable or trending applications.

Note: The correct magnet choice and an adequately prepared mounting surface are critical for obtaining reliable measurements, especially at high frequencies. Poor installations can cause as much as a 50% drop in the sensor frequency range.

Not every magnet is suitable for all applications. For example, rare earth magnets are commonly used because of their high strength. Flat magnets work well on smooth, flat surfaces, while dual-rail magnets are required for curved surfaces. In the case of non-magnetic or rough surfaces, it is recommended that the user first weld, epoxy or otherwise adhere a steel mounting pad to the test surface. This provides a smooth and repeatable location for mounting.

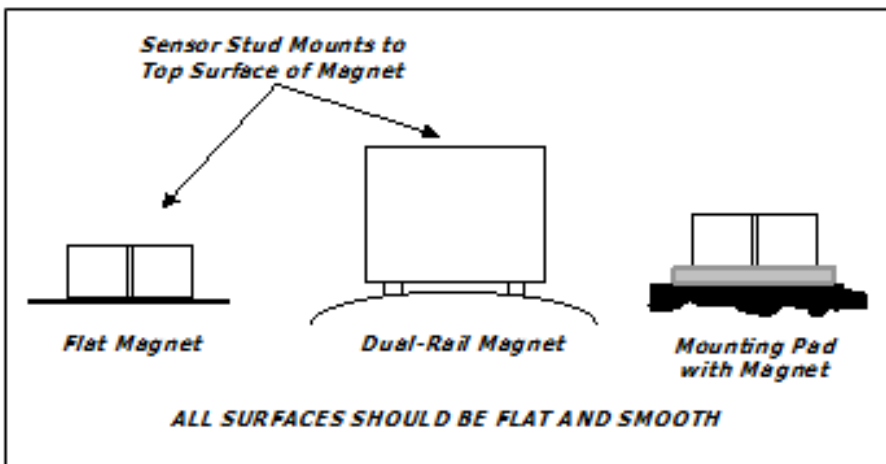

Figure 6 – Magnet Types

- Step 1: After choosing the correct magnet, inspect the unit to verify that the mounting surfaces are flat and smooth.
- Step 2: Stud-mount the accelerometer to the appropriate magnet according to the guidelines set forth in Steps 2 and 3 of the Standard Stud Mount Procedure.
- Step 3: Prepare a smooth, flat mounting surface. A minimum surface finish of 63 μin [0.0016 mm] generally works best. After cleaning the surface and checking for burrs, wipe on a light film of silicone grease, machine oil or similar-type coupling fluid.
- Step 4: Mount the magnet/sensor assembly to the prepared test surface by gently “rocking” or “sliding” it into place.

Note: Magnetically mounting accelerometers carelessly has the potential to generate very high (and very damaging) g levels. To prevent damage, install the assembly gently. If unsure, please contact the factory for assistance.

Wiring

On the following pages are eleven different wiring scenarios for the Smart Switch. The wiring legend below is applicable to all wiring diagrams.

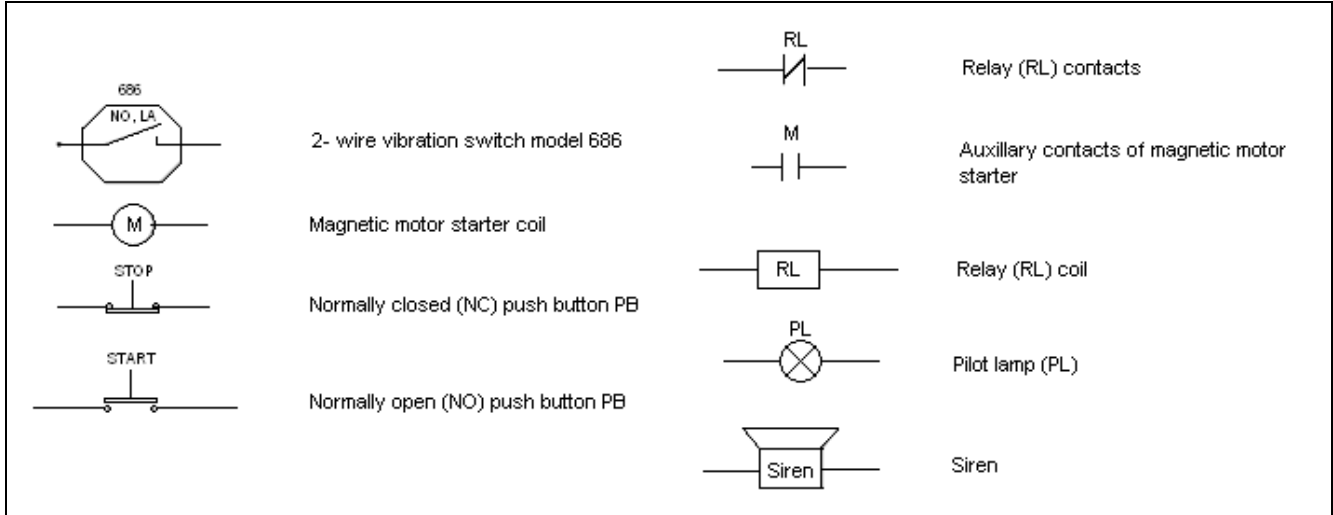
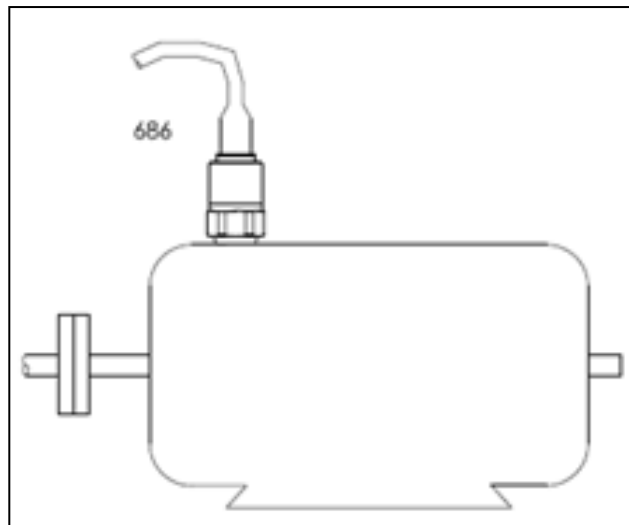
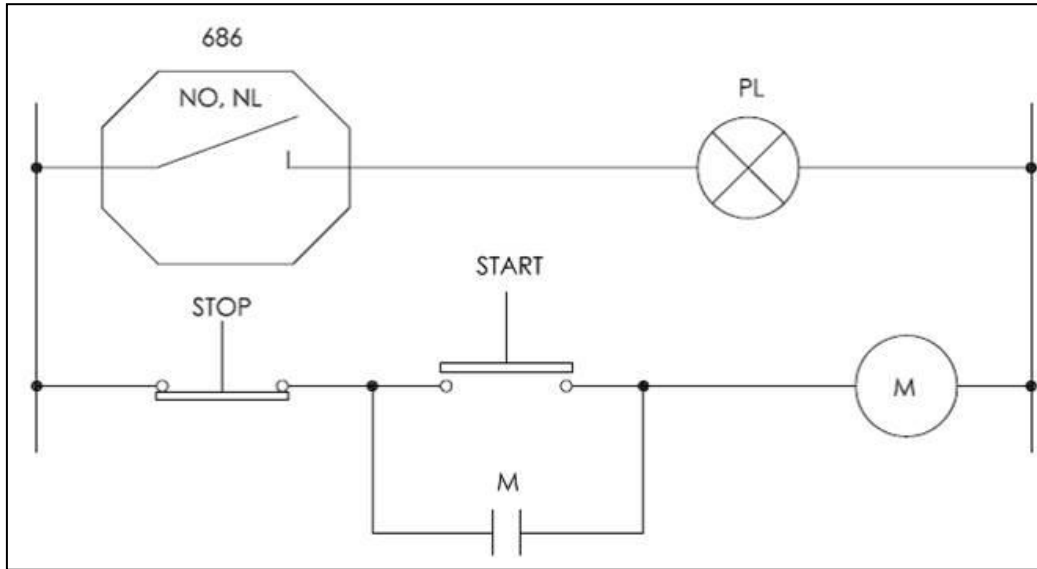

Figure 7 – Wiring Diagrams Legend

For those wiring scenarios that suggest the use of an external electromechanical relay, IMI suggests Omron general purpose relays as listed below. Visit www.omron.com for more information.

Attribute	Omron Model Number				
	MJN2C-AC120	MJN2C-AC240	MJN2C-DC12	MJN2C-DC24	MJN2C-DC110
Contact Form	2 Form C (DPDT)				
Relay Rated Resistive Load	10 A @ 240 VAC/28 VDC				
Service Life- Electrical (Min @Rated Loads)	100,000 operations "average"				
Relay Max Resistive Switching Capacity	2400 VA, 280 W	240 VAC	12 VDC	24 VDC	110 VDC
Coil Nominal Voltage	120 VAC		1.2 W		
Coil Power Consumption	1.7 VA				
Coil Type	Non-Latching				
Seal Type	Unsealed				
Termination Style	Socket Mount				
Operating Temperature Range	-45 to +60 C with no icing or condensation		-45 to +70 C with no icing or condensation		
Dielectric Strength (AC for 1 min)	2500 VAC				
Approved Standards	UL, CSA				

Indicating a High Level of Vibration in a Motor



Figures 8 and 9 – Indicating a High Level of Vibration in a Motor

Pushing the Start pushbutton closes the M contacts and starts the motor. If the start-up delay option for the switch is enabled, the Smart Switch will not trip regardless of the vibration level during the specified delay time. After this delay, the vibration switch will be activated. If the vibration level exceeds the alarm threshold for a time period greater than the specified operational delay time, the relay will trip. This action will close the contact to the pilot lamp.

Since the NL (non-latching) option is specified, the pilot lamp will illuminate only while alarm threshold is exceeded. Should the vibration level drop below the alarm threshold value (based also on the specified hysteresis), the pilot lamp will turn off.

Indicating High Levels of Vibration Simultaneously in Series (Such as Fan & Motor)

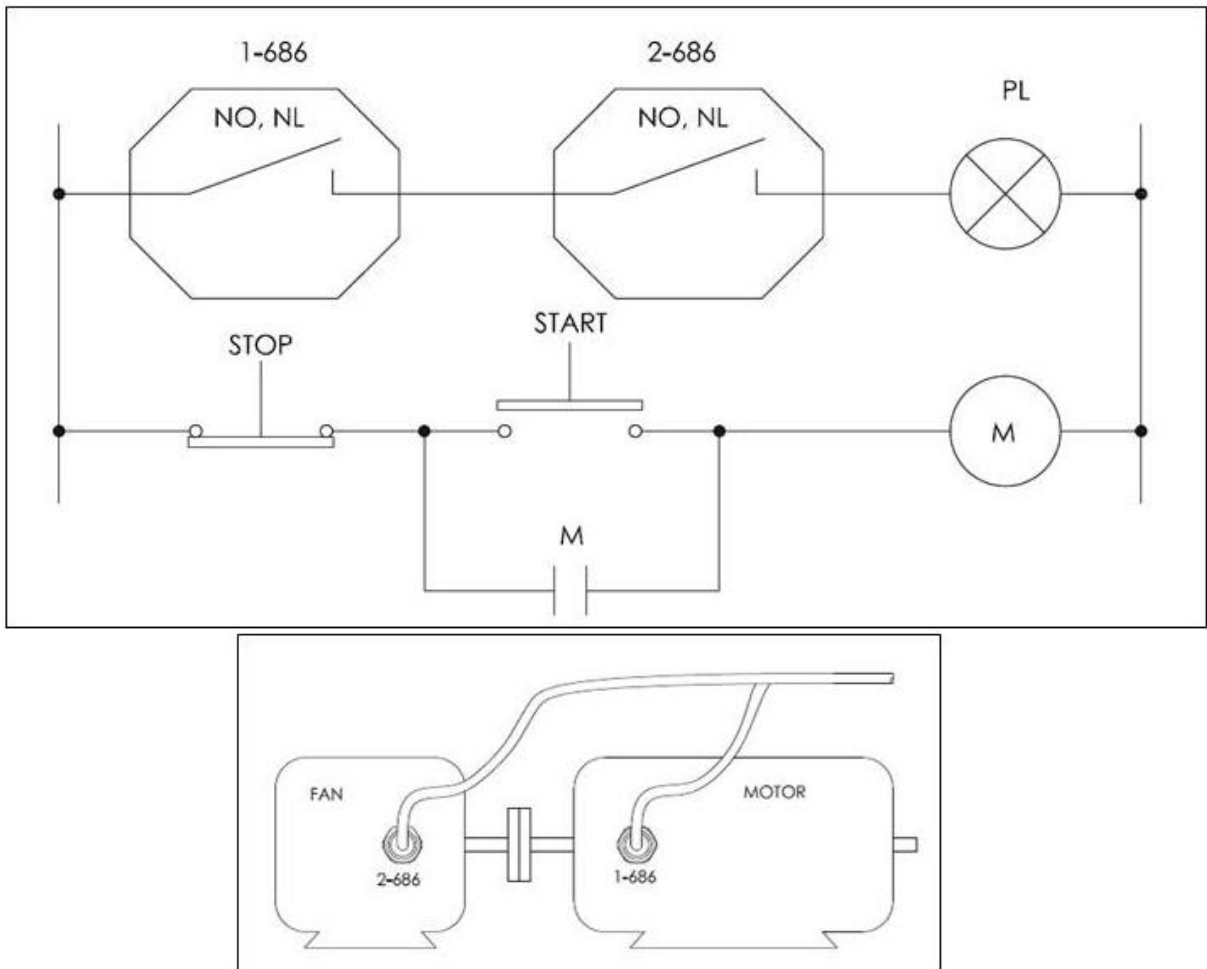

Figures 10 and 11 – Indicating High Levels of Vibration Simultaneously in Series (Such as Fan & Motor)

The Smart Switches are hooked up in series and installed on the two most loaded bearings across the coupling in the horizontal direction. Pushing the Start pushbutton closes the M contacts and starts the motor and fan. If the start-up delay option for the switches is enabled, the Smart Switches will not trip during the specified startup delay time, regardless of the vibration level. After this delay, the switch relays will be activated if the vibration level on both machines exceeds the alarm threshold for a period greater than the specified operation delay time. This action will close the contact to the pilot lamp.

Since the NL (non-latching) option is specified, the pilot lamp will illuminate only while set threshold on both machines is exceeded. Should the vibration level for one or both of the machines drop below the threshold value (based also on the specified hysteresis), the pilot lamp will turn off.

Constant Siren Alarming in the Event of High Vibration Levels

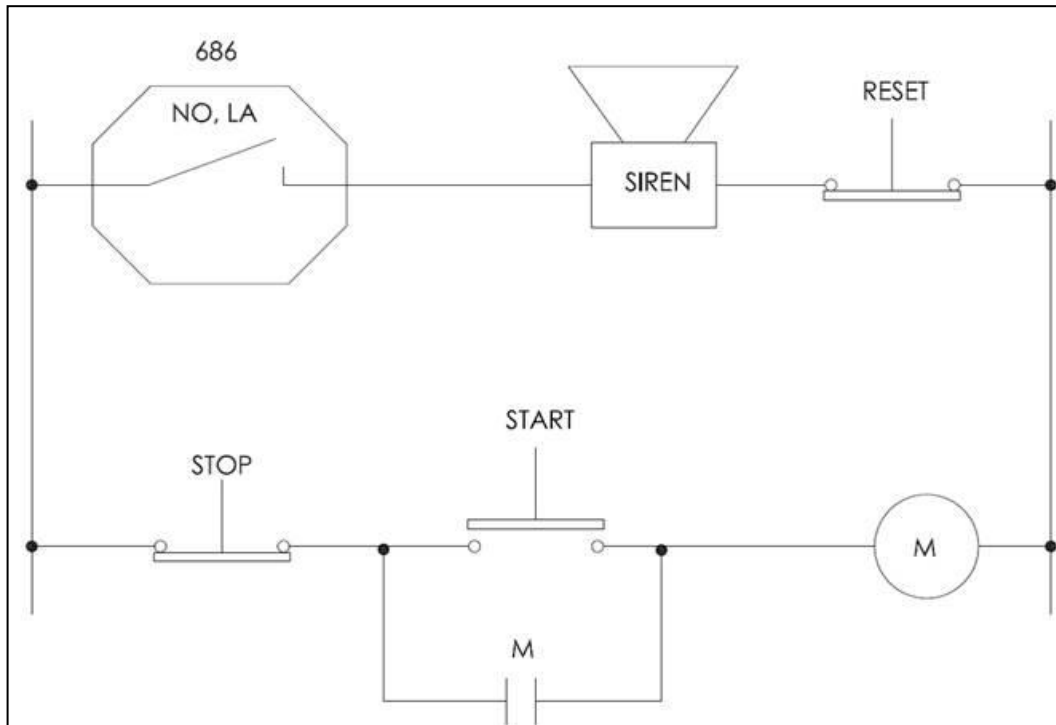
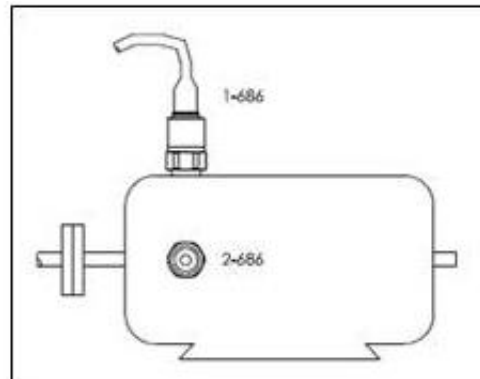
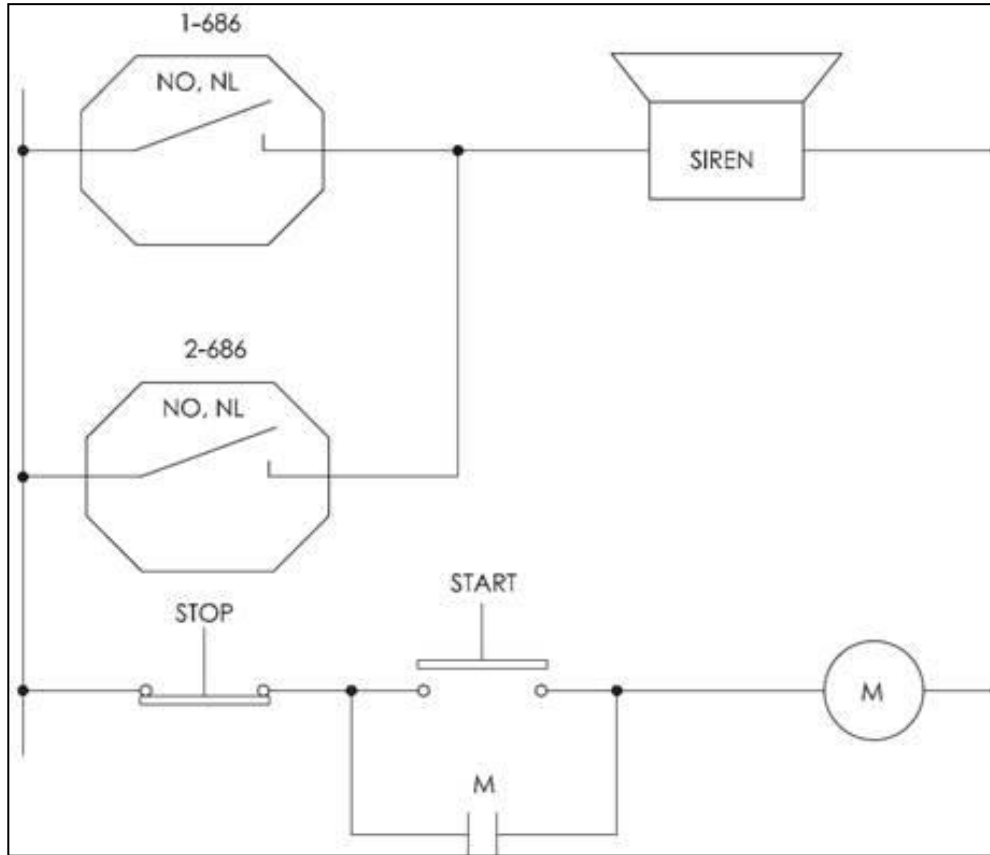

Figure 12 – Constant Siren Alarming in the Event of High Vibration Levels

The Smart Switch is hooked up for automatic constant siren alarming when the alarm threshold level is exceeded. Pushing the Start pushbutton closes the M contact and starts the motor. If the start-up delay option for the switches is enabled, the Smart Switches will not trip during the specified startup delay time, regardless of the vibration level. After this delay, the switch relay will be activated if the vibration level exceeds the alarm threshold for a period greater than the specified operational delay time. This action will close the contact to the alarm siren and activate it.

Since the LA (latching) option is specified, the alarm siren will be constantly energized after this high vibration event, even if the vibration level should drop below the alarm threshold. The Reset pushbutton should be engaged to de-energize the alarm siren and return the system to its original monitoring condition.

Using Two Switches in Parallel to Monitor Two Axes Simultaneously on Same Motor



Figures 13 and 14 – Using Two Switches in Parallel to Monitor Two Axes Simultaneously on Same Motor

The Smart Switches are hooked up in parallel and installed on the motor in horizontal and vertical directions. Pushing the Start pushbutton closes the M contact and starts the motor. If the start-up delay option for the switches is enabled, then during the specified startup delay time, the switches will not trip regardless of the vibration level. After this delay, the alarm siren will be activated if either of the switches experiences a vibration level over the alarm threshold lasting greater than the specified operation delay time.



Since the NL (non-latching) option is specified, the alarm siren will sound while alarm threshold on one or both switches is exceeded. Should the vibration level for both switches drop below the alarm threshold value (based also on the specified hysteresis), the alarm siren will turn off.

Using Three Switches in Parallel to Monitor Three Motors Simultaneously

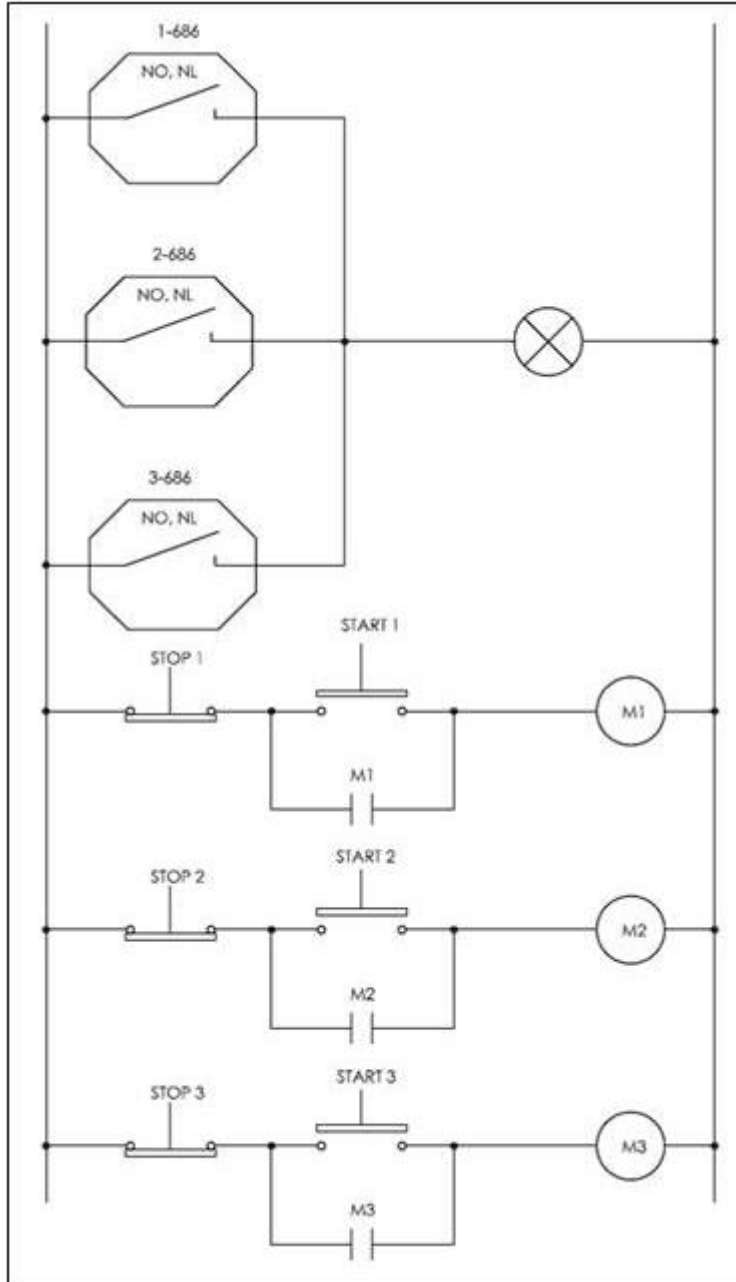

The three Smart Switches are hooked up in parallel and installed on each motor in the horizontal direction. This provides an economical solution for monitoring a group of machinery while only having to run one cable. Pushing any Start pushbutton will close the corresponding M contact and start the motor. If the start-up delay option for the switches is enabled, then during the specified startup delay time, the switches will not trip; regardless of the vibration level. After this delay, the pilot lamp will be illuminated if any of the switches experience a vibration level over the alarm threshold value lasting greater than the specified operational delay time.

Since the NL (non-latching) option is specified, the pilot lamp will illuminate while alarm threshold on any of the switches is exceeded. When the vibration level for all switches drops below their alarm threshold value (based also on the specified hysteresis), the pilot lamp will turn off.

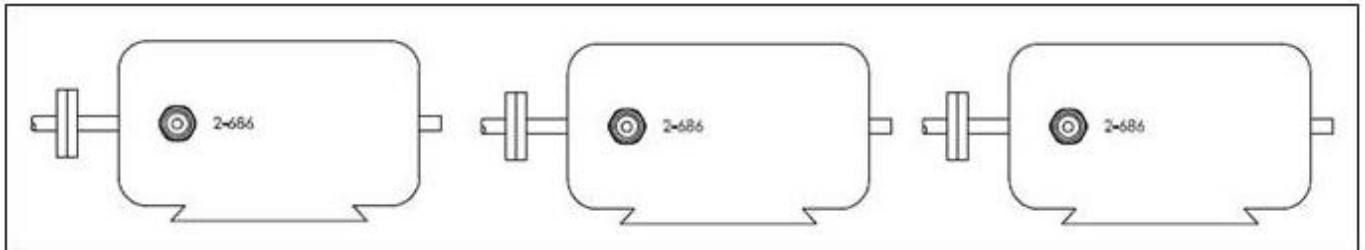

Figures 15 and 16 – Using Three Switches in Parallel to Monitor Three Motors Simultaneously

Automatic Machinery Shutdown Using an External Electromechanical Relay

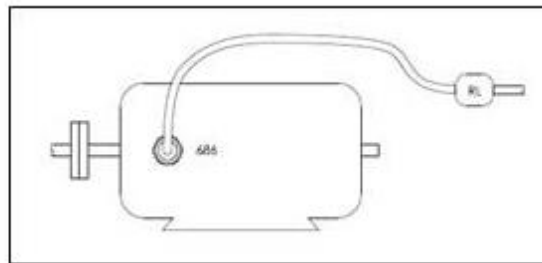
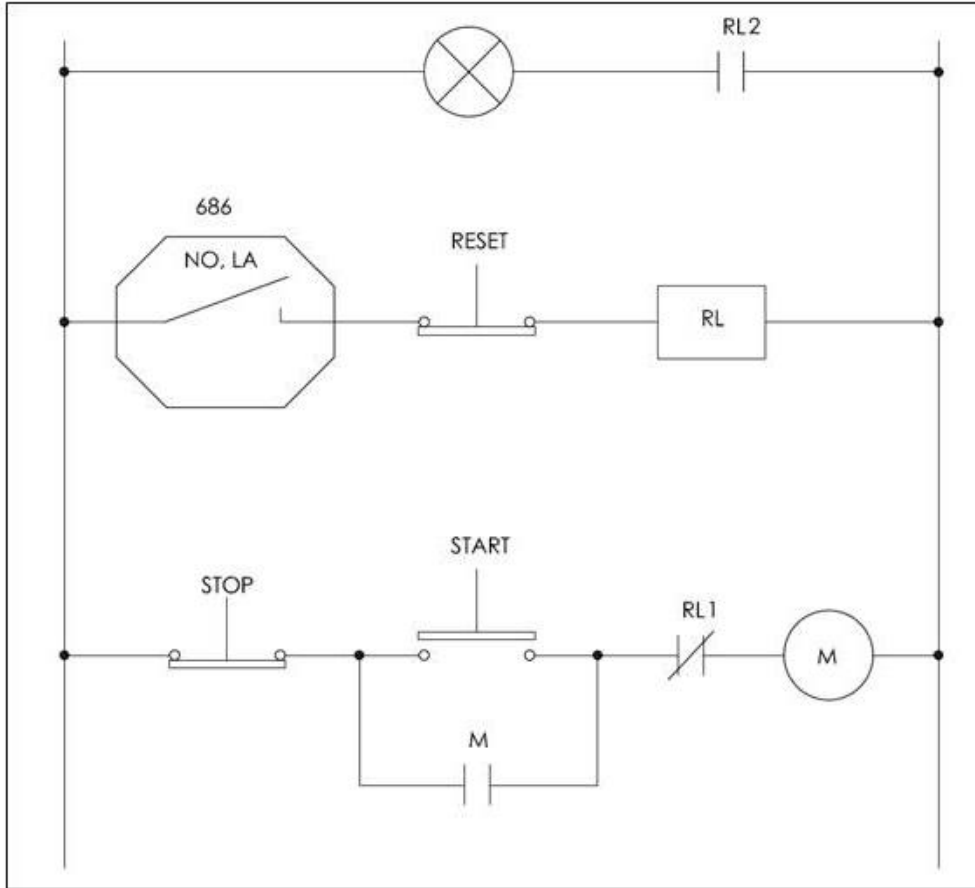

Figures 17 and 18 – Automatic Machinery Shutdown Using an External Electromechanical Relay

The Smart Switch is hooked up for automatic motor shutdown when the alarm threshold level is exceeded. The switch should be mounted in the horizontal direction on the bearing carrying the most load. Pushing the Start pushbutton closes the M contact and starts the motor. If the start-up delay option for the switches is enabled, the Smart Switches will not trip during the specified startup delay time, regardless of the vibration level. After this delay, the switch relay will be activated if the vibration level exceeds the alarm threshold for a period greater than the specified operational delay time. This action will close the contact and send a voltage to the RL relay coil. This will open the RL1 and close the RL2 contacts, shut down the motor, and light the pilot lamp.

Since the LA (latching) option is enabled, the RL coil will be constantly energized after this event; even if the vibration level drops below the alarm threshold value after shutdown. The Reset pushbutton should be pushed to reset the switch and close the RL1 and RL2 contacts before restarting the motor.

Automatic Machinery Shutdown Using an External Electromechanical Relay While Monitoring 2 Axes

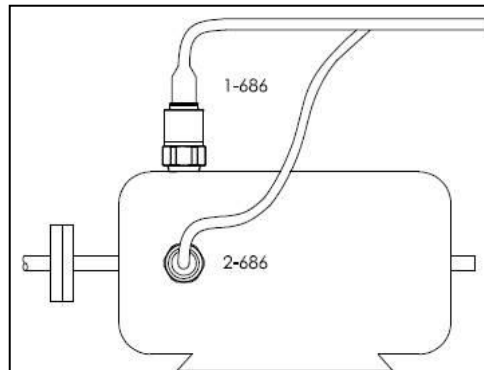
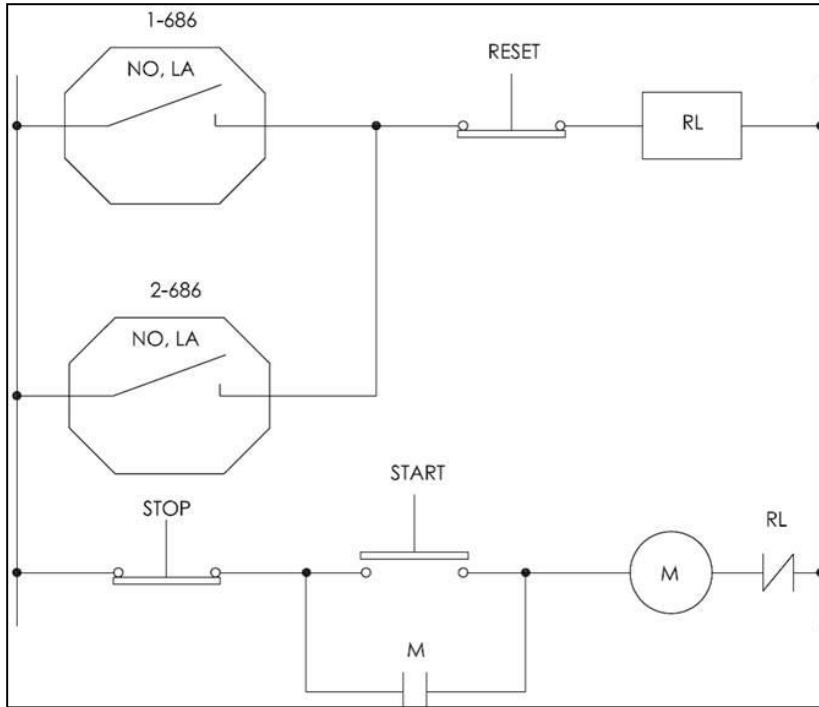

Figures 19 and 20 – Automatic Machinery Shutdown Using an External Electromechanical Relay While Monitoring 2 Axes

The Smart Switches are hooked up in parallel for automatic motor shutdown when the alarm threshold level is exceeded on either switch. The switches should be mounted in the horizontal and vertical direction at the bearing carrying the most load. Pushing the Start pushbutton closes the M contact and starts the motor. If the start-up delay option for the switches is enabled, the Smart Switches will not trip during the specified startup delay time, regardless of the vibration level. After this delay, the switch relay will be activated if the vibration level of either switch exceeds the alarm threshold for a period greater than the specified operational delay time. This action will close the contact and send a voltage to the RL relay coil. This will open the RL contacts and shut down the motor.

Since the LA (latching) option is specified, the RL coil will be constantly energized after this event; even if the vibration level drops below the alarm threshold value after shutdown. The Reset pushbutton should be pushed to reset the switch and close the RL contacts before restarting the motor.

Using the Switch and External Latching for Automatic Machinery Shutdown

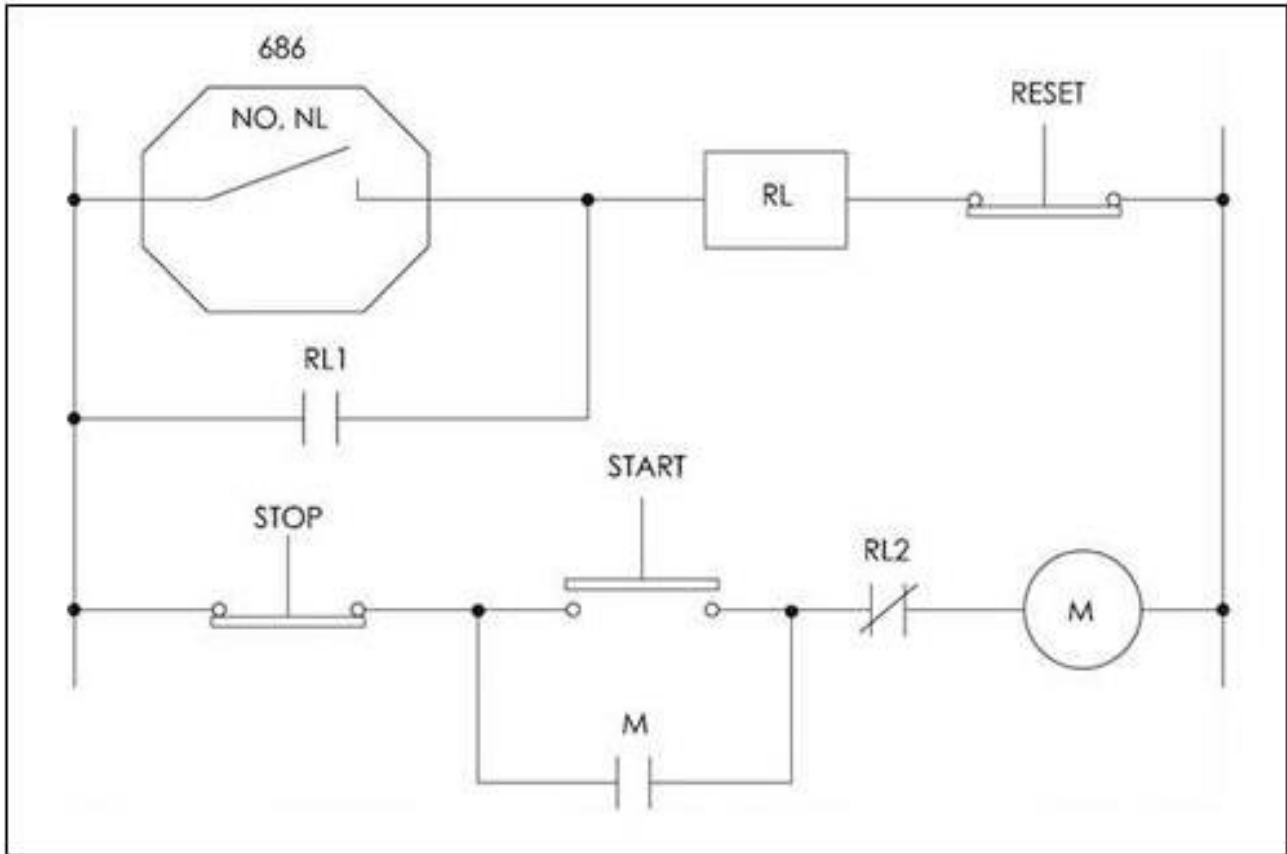

Figure 21 – Using the Switch and External Latching for Automatic Machinery Shutdown

The Smart Switches are hooked up for automatic motor shutdown in case of high vibration levels on critical machinery. Since RL2 contacts are normally closed, pushing the Start pushbutton closes the M contact and starts the motor. If the start-up delay option for the switches is enabled, the Smart Switches will not trip during the specified startup delay time, regardless of the vibration level. After this delay, the switch relay will be activated if the vibration level of either switch exceeds the alarm threshold for a period greater than the specified operational delay time. This action will close the contacts and send a voltage to the RL relay coil. This will open the RL2 contacts and shut down the motor.

Since the LA (latching) option is specified, the RL1 contacts are used for external latching. Closing of RL1 provides constant coil energizing after the shutdown event. Therefore, when the vibration level drops below the alarm threshold level after shutdown, the closed RL1 contacts still energize the RL coil and keep RL2 in the open position. The Reset pushbutton should be pushed to reset the 2-wire switch, close the RL2 contacts and open the RL1 contacts before restarting the motor.

Both Alarm Siren and Automatic Machinery Shutdown Using Two Switches

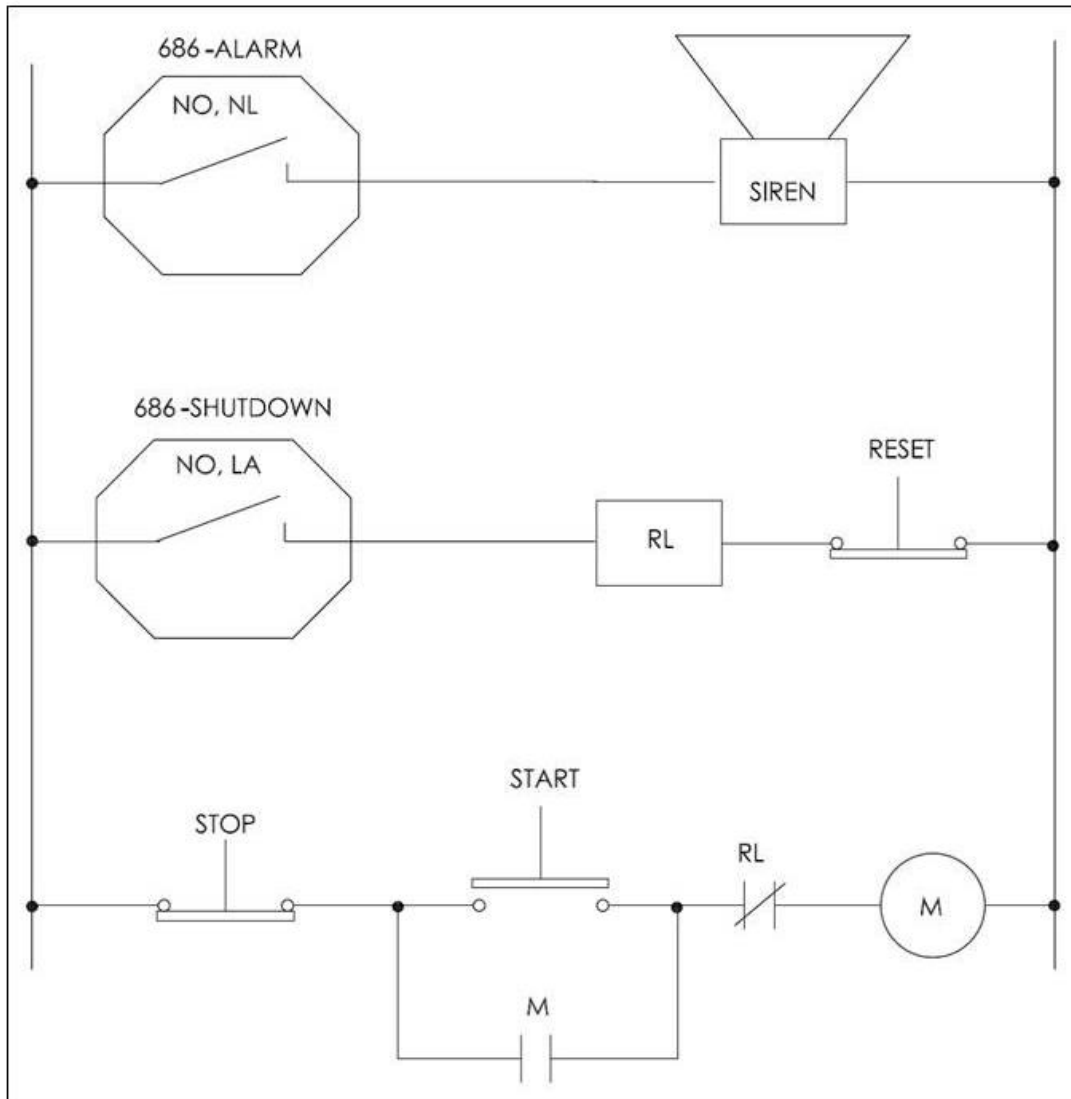

Figure 22 – Both Alarm Siren and Automatic Machinery Shutdown Using Two Switches

The Smart Switches are hooked up for providing alarm siren and automatic motor shutdown when the alarm threshold levels are exceeded. To accomplish this, the two switches have two different threshold values; one for alarm and one for shutdown. Pushing the Start pushbutton closes the M contact, and since RL2 contacts are normally closed, starts the motor. If the start-up delay option for the switch is enabled, the switch will not trip regardless of the vibration level during the specified delay time. After this delay, if the vibration level exceeds the alarm threshold for the alarm switch, it will be activated and apply a voltage to the alarm siren. Since the NL (non-latching) option is specified for this switch, the alarm siren will be energized until the vibration level falls below the alarm threshold value (based also on the specified hysteresis). If the vibration level exceeds the shutdown alarm threshold, the second vibration switch will be activated and apply a voltage to the RL relay coil. This will open the RL contacts and shut down the motor. Since the LA (latching) option is specified, the RL coil will be constantly energized after this event; even though the vibration level will drop below the alarm threshold value after shutdown. The Reset pushbutton should be pushed to reset the switch and close the RL contacts before restarting the motor.

Automatic Machinery Shutdown Based on Normally Open Solid-State Relay

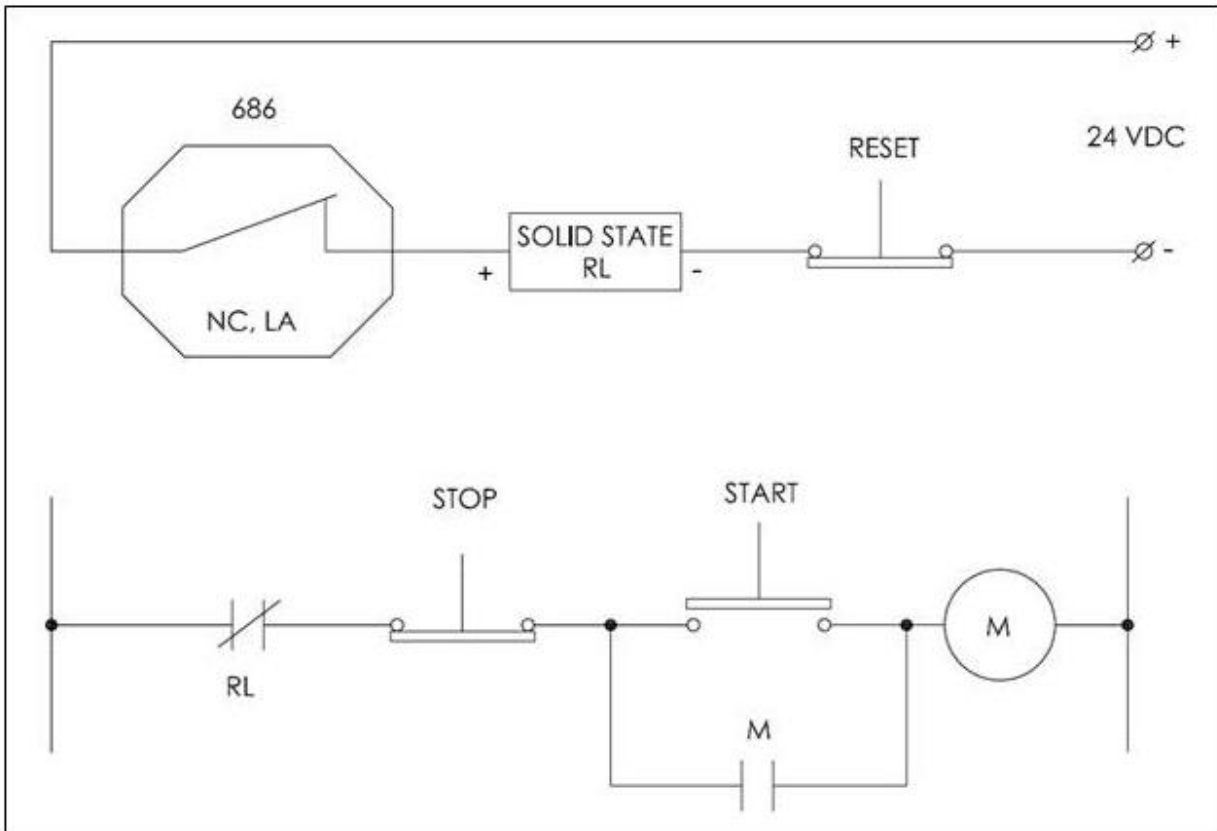

Figure 23 – Automatic Machinery Shutdown Based on Normally Open Solid-State Relay

The Smart Switch is hooked up to provide automatic motor shutdown when the alarm threshold level is exceeded. Pushing the Start pushbutton closes the M contact, and since the switch is Normally Closed, the solid state relay will be energized and the RL contacts will be closed. This will start the motor. If the start-up delay option is enabled, the switch will not trip regardless of the vibration level during the specified delay time. After this delay, if the vibration level exceeds the alarm threshold, it will be activated, thereby opening its contacts and de-energizing the solid state relay input. This will open the RL contacts and shut down the motor. Since the LA (latching) option is specified, the solid state relay input will be constantly de-energized after this event even if the vibration level drops below the alarm threshold value after shutdown. The Reset pushbutton should be pushed to reset the switch and close the RL contacts before restarting the motor.

Automatic Machinery Shutdown of Three-Phase Electrical Motor Based on a N.O. Solid State Relay

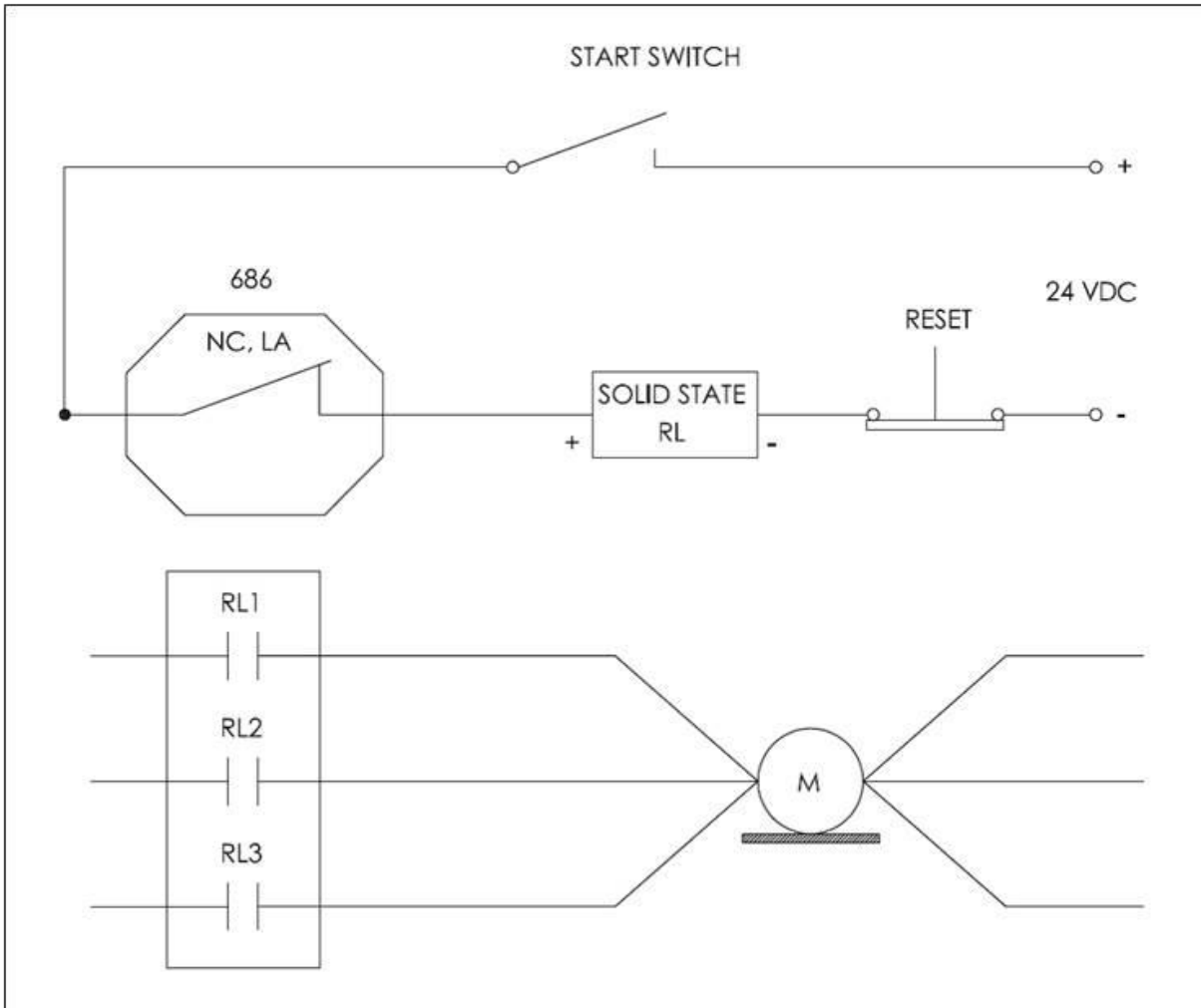

Figure 24 – Automatic Machinery Shutdown of 3-Phase Electrical Motor Based on a N.O. Solid State Relay

The Smart Switch is hooked up to provide automatic motor shutdown when the alarm threshold level is exceeded using a normally open three channel solid state relay. Since the Smart Switch is normally closed, closing the Start Switch will energize the solid state relay. This will cause the RL1, RL2, and RL3 contacts to close and start the motor. If the start-up delay option for the switch is enabled, the switch will not trip regardless of the vibration level during the specified delay time. After this delay, if the vibration level exceeds the alarm threshold, it will be activated, thereby opening its contacts and de-energizing the solid state relay input. This will open the RL1, RL2, & RL3 contacts and shut down the motor. Since the LA (latching) option is specified, the solid state relay input will be constantly de-energized after this event; even if the vibration level drops below the alarm threshold value after shutdown. The Reset pushbutton should be pushed to reset the switch and close the RL1, RL2, & RL3 contacts before restarting the motor. This will start the motor immediately without using the Start pushbutton.

Programming Software

The Smart Switch can be user-programmed with the optional Model 600A29 Programming Kit. The kit includes USB programmer cable/dongle (Model 070A100), software (Model EE225), terminal block/integral cable adapter (Model 042M17) and magnet clip (Model 080A214). The software can also be downloaded from IMI's website, www.pcb.com. This software must be installed prior to connecting the Smart Switch to the computer using the USB programmer cable. The software includes both the drivers and user interface needed for programming the Smart Switch. During initial installation, you may need administrative rights for the computer in order to install the drivers. Once installed, administrative rights are not required for use.



Figure 25 – Model 600A29 USB Programmer Kit

Program Installation

Installing the Software and USB Driver: Insert the software CD provided into the CD drive. The software will start the installation automatically if your PC is set to auto-install applications. If not, browse the CD and click on Setup.exe to start the installation process. The default installation directory is C:\PCB\EE225. It is recommended to use the default setting.

The installer will first install the software and then the WinUSB device driver. This device driver is required for the programmer software to communicate with the 070A100 USB programmer cable included in the programmer kit.

The following screens will be displayed when the installer starts. Click the Next button to proceed from step to step.

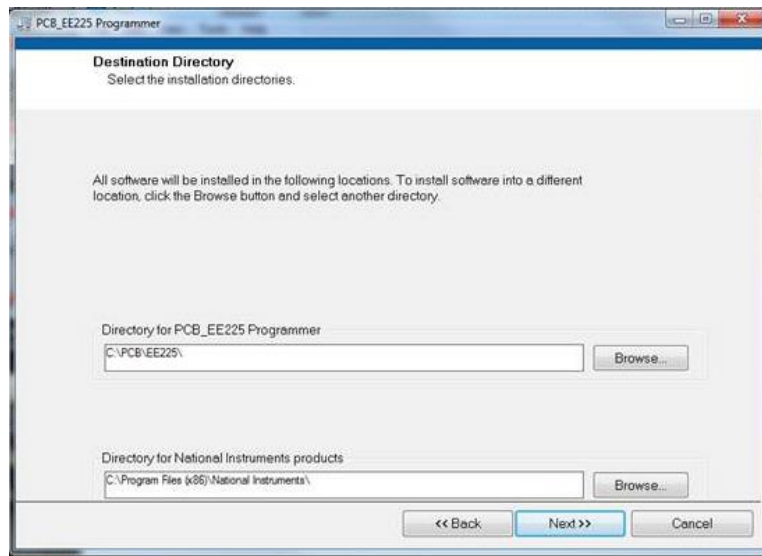

Figure 26 – Install Location Screen

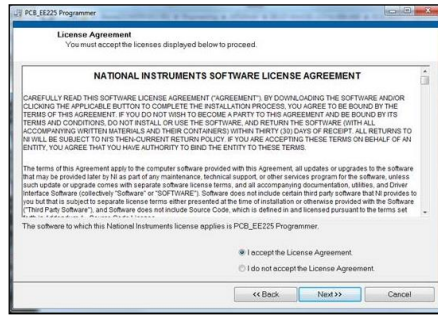

Figure 27 – National Instruments Software License Agreement

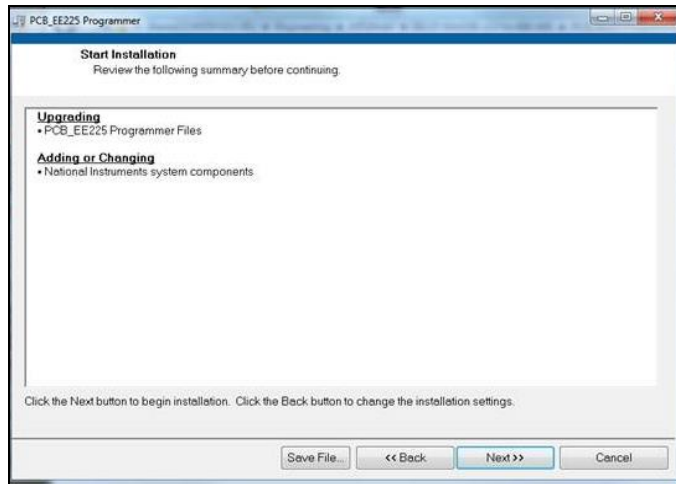

Figure 28 – Installation Verification Screen

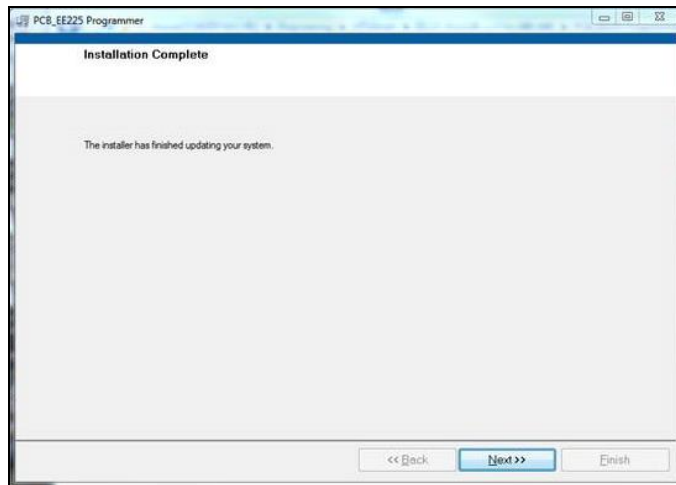

Figure 29 – Installation Complete Screen

After the software completes, the USB driver installer will start automatically. The initial USB installer will look similar to the one below.



Figure 30 – WinUSB Driver Installation Screen

The drivers will now be properly installed and you should get the following screen. Click “Finish”. The software is now ready to use.



Figure 31 – WinUSB Driver Installation Complete Screen

Running the Software

Connect the USB programmer cable to the Smart Switch. Hold a magnet to the indicated MAVT™ point on the Smart Switch. Wait about 2 seconds. While keeping the magnet against the Smart Switch, connect the USB programmer cable to a USB port on the PC. Run the software from the Start | All Programs | PCB EE225 Software menu item.

Initially the screen will appear as in **Error! Reference source not found.** with a yellow bar and status indicating ‘Initializing...’ followed by the message: “Connecting to USB Dongle...”.

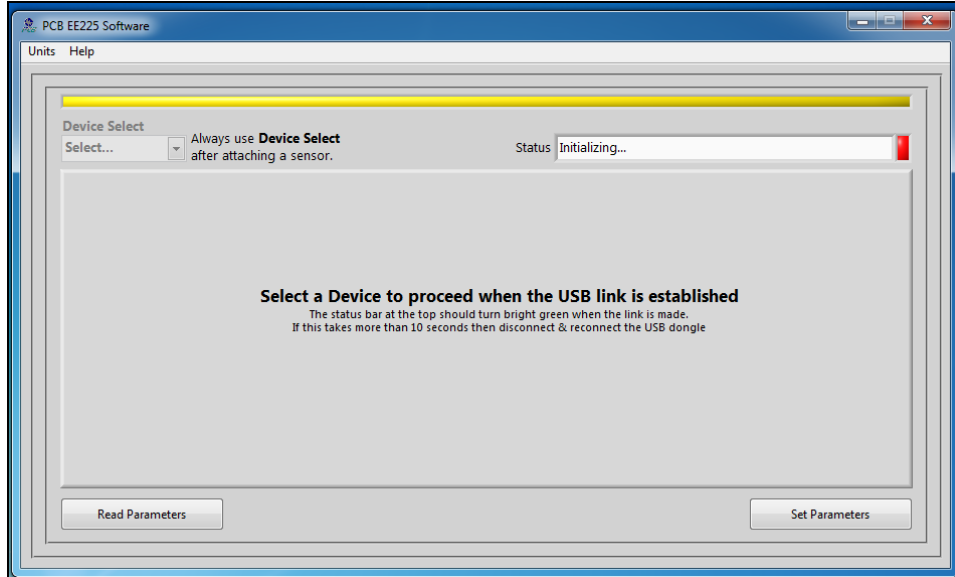

Figure 32 – Software While Connecting to USB Programmer Cable

Once the connection is made the bar at the top of the screen will turn green and the status will indicate “USB Connection Success - Select a device”. If the software and USB programmer cable fail to connect, remove and reinsert the USB programmer cable.

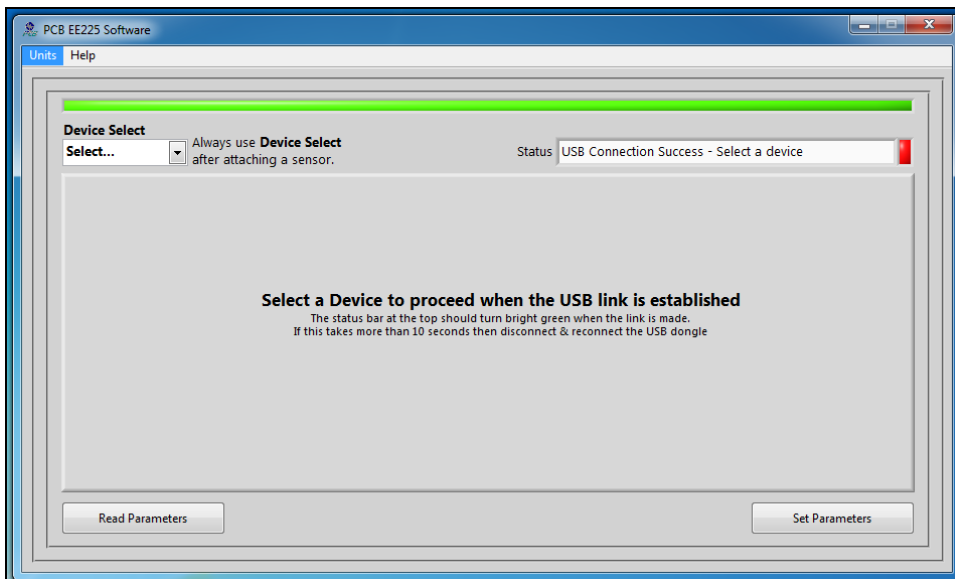

Figure 33 – Software After Connecting to USB Programmer Cable

To select a device, click on the Device Select pull down menu and select the device you'd like to program. In this case, select 686.

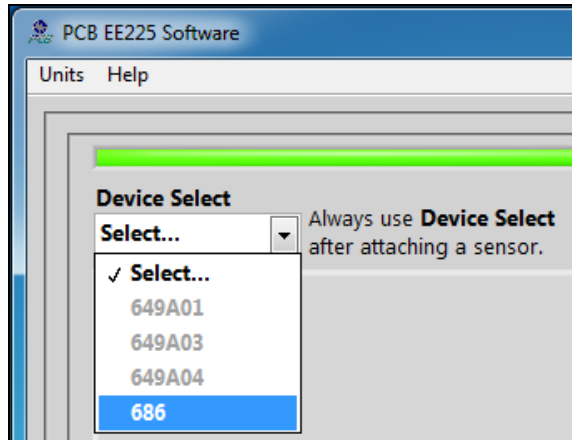

Figure 34 – Device Selection

Once a product is selected, the software will prompt you to confirm connection of the sensor to the PC using the USB programmer cable. Click OK to proceed.

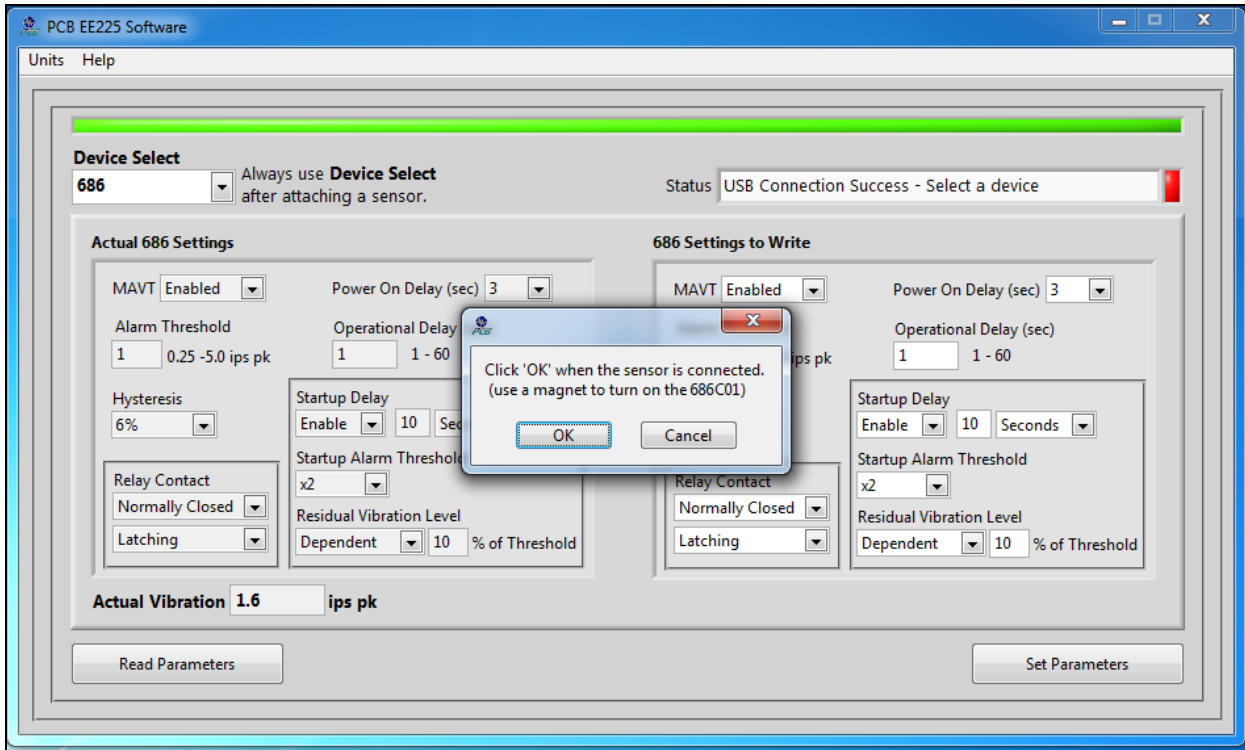

Figure 35 – Sensor Connection Screen

While the software is establishing communication with the sensor, the status will display 'Checking Status...' and the colored indicator box next to the status will alternate between red and yellow. This will take approximately 15 seconds. Once communication is established, the indicator box will turn green and the software will read the sensor's current settings and data. The fields presented in the main body of the screen will be specific to the selected sensor.

Programming Sections

The screen has two sections:

- Actual 686 Settings – This section shows the settings currently programmed in the sensor.
- 686 Settings to Write – This section shows the options for programming the sensor.

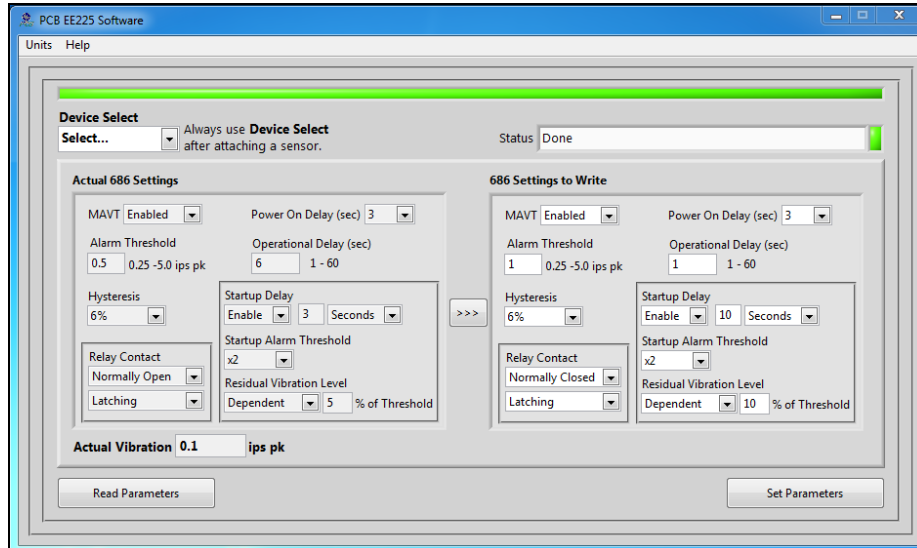

Figure 36 – Typical Smart Switch Screen After Successful Parameter Read

Reading and Writing Parameters

- Reading Parameters - To read the current sensor settings, click the Read Parameters button. This operation takes approximately 45 seconds to complete.
- Transferring Actual Settings to Settings to Write Field - Use the '>>>' button to transfer all Actual Settings to the Settings to Write fields.
- Writing Parameters- Select the appropriate mode and enter any pertinent parameter information. Click the Set Parameters button. This causes the settings to be sent to the sensor and then read back and displayed in the Actual 686 Settings.

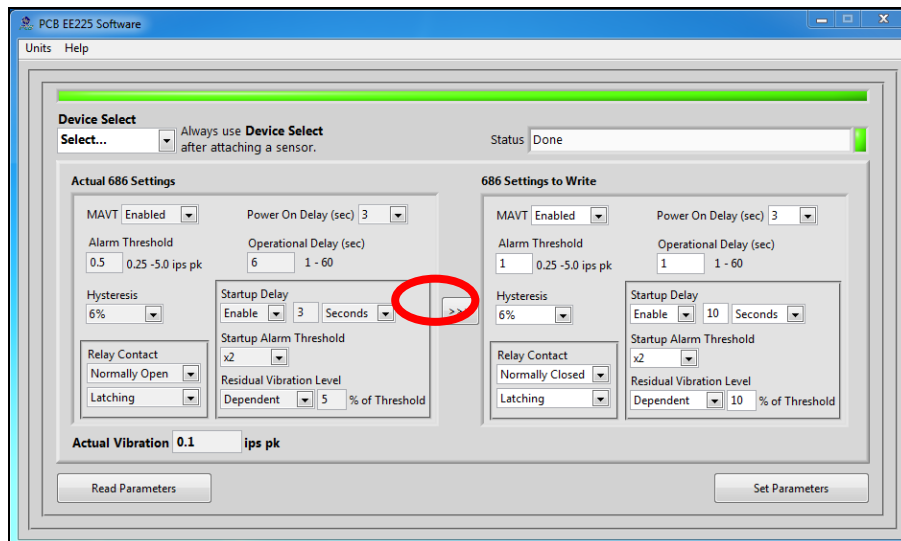

Figure 37 – Transferring Actual Settings to Settings to Write Field

Parameter Options

The software presents one read-only parameter (Actual Vibration) and several parameters that can be programmed to optimize performance of the Smart Switch. At any point during the programming process, the values can be changed between imperial and metric measurements by clicking the Units dropdown in the top navigation menu and then selecting the appropriate measurement type.

Parameter	Description	Acceptable Value(s)
Actual Vibration	Actual vibration (ips pk) being sensed by the switch at time when Read Parameters button is clicked.	N/A
MAVT™	Capability to determine and set the alarm threshold value automatically by the Smart Switch based on the actual vibration level measured by it. For more information about the MAVT™ feature, see page 16.	Enabled Disabled
Alarm Threshold	Vibration level at which the relay will change state.	0.25- 5.0 ips pk 6.35-127 mm/s pk
Hysteresis	Percentage that actual vibration must fall below the alarm threshold in order for a non-latching relay to automatically reset itself. Hysteresis prevents a relay from continually changing states when the vibration level is hovering around the alarm threshold level.	3% 6% 10%
Relay Contacts- Normal State	State in which the relay stays when not tripped.	Normally Open Normally Closed
Relay Contacts- Reset State	How the relay operates once actual vibration falls below the alarm threshold. <ul style="list-style-type: none"> Latching: Relay to latch or stay in the alarm state until manually reset regardless of the vibration level. Non-Latching Relay automatically resets once the vibration level falls below the alarm threshold (hysteresis) level. 	Latching Non-Latching
Power On Delay	Specified time period immediately after power is applied to the switch during which the relay will not trip regardless of the vibration level. Prevents a relay trip during high transient vibration levels that may occur during a normal machine startup.	3 sec 20 sec
Operation Delay	Specified time period for which actual vibration must constantly exceed the Alarm Threshold before the relay changes state. Prevents a relay trip as a result of a short transient spike in vibration level that may not even be caused by a machine fault.	1-60 sec
Startup Delay- Status	Specified time period immediately after power is applied to the equipment being monitored during which the relay will not trip regardless of vibration level.	Enabled Disabled
Startup Delay- Time Period	Time period during which vibration is ignored.	1-60 sec 1-30 min
Startup Delay- Startup Alarm Threshold	Maximum vibration ignored during the time period. Calculated as a multiple of the Alarm Threshold.	2x 4x 8x Blocked (All vibration)
Startup Delay- Residual Vibration Level	Minimum vibration level that, once surpassed at equipment startup, triggers the countdown of the Startup Delay Time Period.	Dependent (Threshold %) Independent (Value) Max 40% of Threshold

Unless otherwise specified, the Smart Switch comes from the factory with a set of default parameters. The specific set of parameters depends on the last alphanumeric character in the model number.

		Last Alphanumeric Character					
		1	2	3	4	X	
Parameter	MAVT™	Enabled					Custom, Customer-Specific Configuration
	Alarm Threshold	0.60 ips					
	Hysteresis	6%					
	Relay Contacts-Normal State	Normally Open	Normally Closed	Normally Open	Normally Closed		
	Relay Contacts-Reset State	Latching	Latching	Non-Latching	Non-Latching		
	Power On Delay	3 sec					
	Operation Delay	6 sec					
	Startup Delay-Status	Enabled					
	Startup Delay-Time Period	3 sec					
	Startup Delay-Startup Alarm Threshold	2x					
	Startup Delay-Residual Vibration Level	Dependent 5% of Threshold					

Execution of Delays

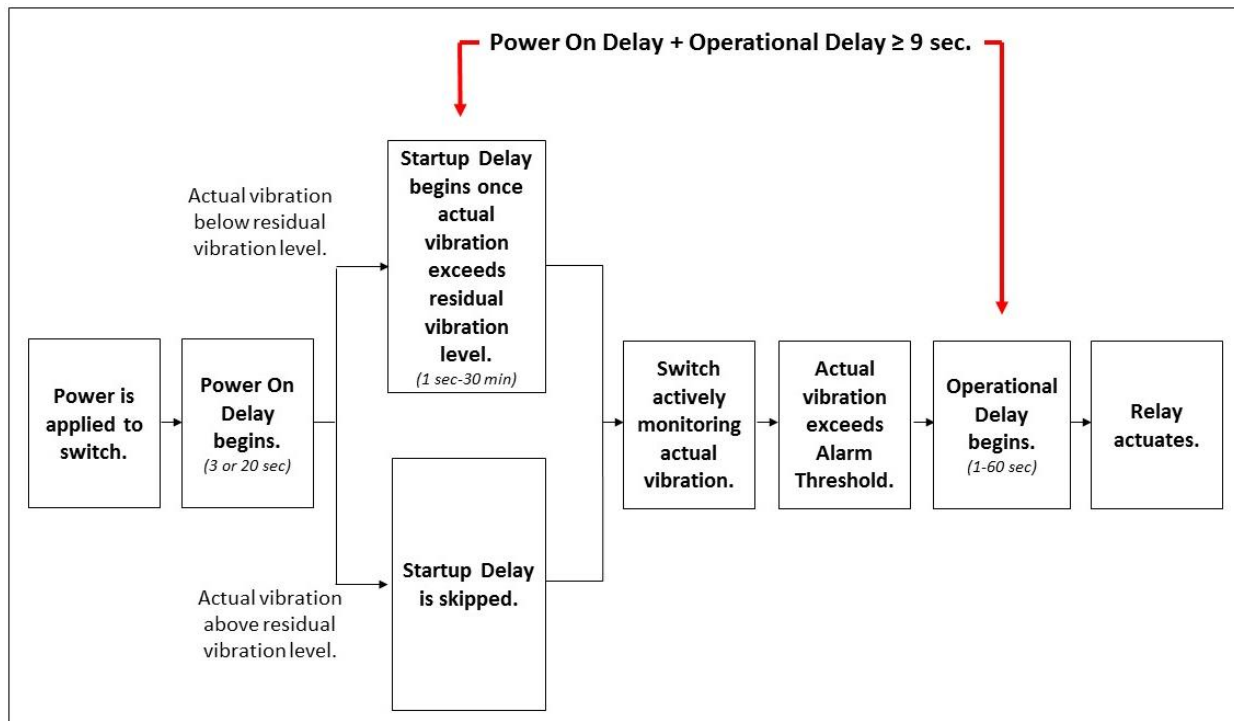

Magnetically Adjustable Vibration Threshold (MAVT™)

Magnetically Adjustable Vibration Threshold (MAVT™) is a Smart Switch selectable feature via USB programming. This unique capability allows the alarm threshold value to be determined and set automatically by the Smart Switch based on the actual vibration level being measured by it. This convenient feature permits any machine to be protected by a vibration switch within seconds without knowing anything about its vibration levels.

The Smart Switch has no accessible mechanical adjustments (ie. screw pots or DIP switches) that are found on other style electronic vibration switches. However, when the MAVT™ option is selected, the hermetically-sealed switch becomes adjustable through magnetic actuation. By touching a specified location on the housing with a strong permanent magnet for 2 seconds, an internal microprocessor is actuated that initiates the test sequence.

Note: The magnet clip (Model 080A214) is a supplied accessory when the Smart Switch is ordered from the factory with the optional 600A29 USB Switch Programmer Kit.



Figure 38 – Magnet Clip

MAVT™ Procedure

Be absolutely sure you do not have the switch connected to the machine's trip circuit during this procedure as the trip relay is activated several times during the procedure and will cause the machine to shut down and turn on several times. This could cause damage to your machinery.

1. Mount the Smart Switch on the machine that the switch will monitor. Be sure that the machine is operating in a steady state condition. If it is not operating, turn the machine on and allow enough time for the vibration level to normalize before going to the next step.
2. Connect the switch to the power supply using an appropriate cable. Since the Smart Switch operates off universal power, any power supply that outputs 24-240 VDC or 24-240 VAC, 50/60 Hz will work. A simple 24V power supply/signal conditioner (Model 480C02) will also work well and has the added advantage of visually indicating when the calibration process has been completed via its built-in meter. Allow 30 seconds for the switch to power up.
3. Touch the permanent magnet to the target on the side of the switch for approximately 2 seconds to initiate the process.
4. The alarm threshold calibration process takes approximately 30 seconds. (The amount of time needed varies based on the difference between the previous and new alarm threshold values.) During this process, the unit will measure the average vibration amplitude, set the alarm threshold value to two times this average value and store this value in a non-volatile memory. The relay contacts open and close repeatedly during this process.
5. Disconnect the Smart Switch from the power supply.
6. The switch can now be permanently installed on the machine for protection.

Factory Programmed Ordering Guide

Switch Model Number Template

6 8 6 /

Use for Integral Cable Models Only

-

Prefix Option

- Blank** No Prefix Option
- EX** CSA Approval
- M** Metric Stud (Not w/ Terminal Block)
- EXM** Metric Stud, CSA Approval (Not w/ Terminal Block)

Version

- B** B Version (All models except those listed for C version)
- C** C Version (Models 686C01 & 686C0X only)

Electrical Connection

- 0** 2-Pin Mil-C-5015 Connector
- 1** Integral Cable
- 6** Integral Armored Cable
- 7** Terminal Block

Program Configuration

- 1 1 0 060 1 06 0 0 1 0 03 0 0 005
- 2 " " " " " 1 " " " " " " " "
- 3 " " " " " 2 " " " " " " " "
- 4 " " " " " 3 " " " " " " " "
- X Custom Program Configuration (Fill out form below)

Cable Length Units

- Blank** English (ft)
- M** Metric (m)

Cable Length

- 001 to 200** Cable Length in ft
- 001 to 060** Cable Length in m

Cable Termination

- AB** BNC Jack
- AC** BNC Plug
- AD** Pigtail
- BZ** Blunt Cut

Armor Length

- Blank** Same as Cable Length
- 001 to 050** Armor Length in ft
- 001 to 015** Armor Length in m

Suffix Option

- Blank** No Suffix Option
- D** ATEX/IECEx Ex d Approval (EX prefix must also be selected)

Custom Program Configuration

MAVT™

A

0	Disabled
1	Enabled

Alarm Threshold

B

0	English
1	Metric

C

Value = 0.25 to 5.00 ips pk
04.5 to 90.0 mm/sec pk

e.g.: 0.25 ips =

0	2	5
---	---	---

25.4 mm/sec =

2	5	4
---	---	---

Hysteresis

D

0	3%
1	6%
2	10%

Operational Delay

E

Value = 01 to 60 sec

Relay Contact

F

0	Latching, Normally Open
1	Latching, Normally Closed
2	Non-Latching, Normally Open
3	Non-Latching, Normally Closed

Power On Delay

G

0	3 sec
1	20 sec

Startup Delay

H

0	Disabled
1	Enabled

I

0	Seconds
1	Minutes

J

Value = 01 to 60 sec. or 01 to 30 min.

Alarm Threshold During Startup

(Multiplier of the Alarm Threshold)

K

0	x2
1	x4
2	x8
3	Blocked

Residual Vibration Level

L

0	Dependent
1	Independent

M

Value = For **Dependent** 001 to 040% of Alarm Threshold.
For **Independent** 0.01 to 5.00 ips
00.1 to 90.0 mm/sec

Figure 39 – Ordering Guide

Battery-Powered Signal Conditioner

Power supply/signal conditioner (Model 480C02) is for use with the Smart Switch when determining the alarm threshold level using the MAVT™ feature. The built-in meter indicates when the process is complete. See www.pcb.com for product details.



Figure 40 – Battery Powered Signal Conditioner

Calibration Cable

The calibration cable (Model 052BR010AC) is a 10 foot, twisted-pair, shielded cable with a 2-Pin MIL type connector terminating to a BNC plug for use with 480C02 power supply and Smart Switch.



Figure 41 – Calibration Cable

Magnet Clip

The magnet clip (Model 080A214) is supplied as part of the optional 600A29 USB Programmer Kit or can be ordered separately for use with the MAVT™.



Cable Ordering Information

Go to www.pcb.com for complete information on cables.

IMI Part Number: **052** **BR** **010** **BZ**

Cable Model Series

- 052 Polyurethane, Shielded, Twisted Pair
- 048 Armored Polyurethane, Shielded, Twisted Pair

Switch Connector Type

- AE 2 socket MIL type with environmental boot
- BP 2 socket MIL type high temp with strain relief
- BR 2 socket MIL type molded composite
- BQ 2 socket MIL type molded composite, right angle

Cable Length

- 010 10 feet
- 020 20 feet
- 030 30 feet
- 040 40 feet
- 050 50 feet
- XXX Any length

Cable termination

- BZ Blunt Cut
- (Consult factory for additional options)



Warning 1 – ESD sensitivity

The power supply/signal conditioner should not be opened by anyone other than qualified service personnel. This product is intended for use by qualified personnel who recognize shock hazards and are familiar with the safety precautions required to avoid injury.

Warning 2 – ESD sensitivity

This equipment is designed with user safety in mind; however, the protection provided by the equipment may be impaired if the equipment is used in a manner not specified by PCB Piezotronics, Inc.

Caution 1 – ESD sensitivity

Cables can kill your equipment. High voltage electrostatic discharge (ESD) can damage electrical devices. Similar to a capacitor, a cable can hold a charge caused by triboelectric transfer, such as that which occurs in the following:

- *Laying on and moving across a rug,*
- *Any movement through air,*
- *The action of rolling out a cable, and/or*
- *Contact with a non-grounded person.*

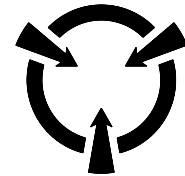

CAUTION
ELECTROSTATIC
DISCHARGE SENSITIVE

The PCB solution for product safety:

- *Connect the cables only with the AC power off.*
- *Temporarily “short” the end of the cable before attaching it to any signal input or output.*

Caution 2 – ESD sensitivity

ESD considerations should be made prior to performing any internal adjustments on the equipment. Any piece of electronic equipment is vulnerable to ESD when opened for adjustments. Internal adjustments should therefore be done ONLY at an ESD-safe work area. Many products have ESD protection, but the level of protection may be exceeded by extremely high voltage.

Warranty

IMI instrumentation is warranted against defective material and workmanship for 1 year unless otherwise expressly specified. Damage to instruments caused by incorrect power or misapplication, is not covered by warranty. *If there are any questions regarding power, intended application, or general usage, please consult with your local sales contact or distributor.* Batteries and other expendable hardware items are not covered by warranty.

Service

Because of the sophisticated nature of IMI instrumentation, field repair is typically **NOT** recommended and may void any warranty. If factory service is required, return the instrumentation according to the "Return Procedure" stated below. *A repair and/or replacement quotation will be provided prior to servicing at no charge.* Before returning the unit, please consult a factory IMI applications engineer concerning the situation as certain problems can often be corrected with simple on-site procedures.

Return Procedure

To expedite returned instrumentation, contact a factory IMI applications engineer for a RETURN MATERIAL AUTHORIZATION (RMA) NUMBER. Please have information available such as model and serial number. Also, to insure efficient service, *provide a written description of the symptoms and problems with the equipment to a local sales representative or distributor, or contact IMI if none are located in your area.*

Customers outside the U.S. should consult their local IMI distributor for information on returning equipment. For exceptions, please contact the International Sales department at IMI to request shipping instructions and an RMA. For assistance, please call (716) 684-0003, or fax us at (716) 684-3823. You may also receive assistance via e-mail at imi@pcb.com or visit our web site at www.pcb.com.

Customer Service

IMI, a division of PCB Piezotronics, guarantees **Total Customer Satisfaction**. If, at any time, for any reason, you are not completely satisfied with any IMI product, IMI will repair, replace, or exchange it at no charge. You may also choose to have your purchase price refunded.

IMI offers to all customers, at no charge, 24-hour phone support. This service makes product or application support available to our customers, day or night, seven days a week. When unforeseen problems or emergency situations arise, call the **IMI Hot Line at (716) 684-0003**, and an application specialist will assist you.

	ENGLISH	SI	
Performance			
Alarm Threshold	0.25 to 5 in/sec pk	4.5 to 90 mm/s rms	[1]
Frequency Range(± 3 dB)	420 to 60 kcpm	7 to 1,000 Hz	
Hysteresis(% < Alarm Threshold)	3; 6; or 10 %	3; 6; or 10 %	[1]
Residual Vibration Level(Reference)	Dependent or Independent	Dependent or Independent	[1]
Residual Vibration Level (% Alarm Threshold)	1 to 40 %	1 to 40 %	[1]
MAVT(Sets Alarm Threshold to 2X actual vibration)	Enabled or Disabled	Enabled or Disabled	[1]
Transverse Sensitivity	< 3 %	< 3 %	
Power On Delay	3 or 20 sec	3 or 20 sec	[1]
Startup Delay(Time)	1 to 60 sec or 1 to 30 min	1 to 60 sec or 1 to 30 min	[1]
Startup Delay(x Alarm Threshold)	x2; x4; x8; Blocked	x2; x4; x8; Blocked	[1]
Startup Delay(Active)	Enabled or Disabled	Enabled or Disabled	[1]
Operational Delay	1 to 60 sec	1 to 60 sec	[1]
Relay(Type)	SPST, Form A or B MOSFET	SPST, Form A or B MOSFET	
Relay (Capacity)	24 to 240 V AC/DC, 500 mA	24 to 240 V AC/DC, 500 mA	
Relay (Latching)	Latching / Non-Latching	Latching / Non-Latching	
Relay (Contacts)	Normally Open / Closed	Normally Open / Closed	
Environmental			
Temperature Range(Operating)	-40 to 185 °F	-40 to 85 °C	
Temperature Range (Storage)	-40 to 257 °F	-40 to 125 °C	
Overload Limit(Shock)	5,000 g pk	49,050 m/s ² pk	
Humidity Range(Condensing)	0 to 100 %	0 to 100 %	
Enclosure Rating	IP67	IP67	[2]
Electrical			
Power Required	24 to 240 V DC/AC 50/60 Hz	24 to 240 V DC/AC 50/60 Hz	
Current Rating(Relay Closed)	500 mA	500 mA	
Leak Current(Relay Open)	1 mA	1 mA	
Electrical Isolation(Case)	> 10 ⁸ Ohm	> 10 ⁸ Ohm	
Physical			
Size - Hex	1.25 in	1.25 in	
Size - Height	2.6 in	66 mm	
Weight	5.2 oz	148 gm	
Mounting Torque	3 to 5 ft-lb	4 to 7 Nm	
Mounting Thread	1/4-28 Female	1/4-28 Female	
Sensing Element(Internal)	Piezoelectric Accelerometer	Piezoelectric Accelerometer	
Housing Material	Stainless Steel	Stainless Steel	
Sealing	Welded Hermetic	Welded Hermetic	
Electrical Connector	Molded Integral Cable	Molded Integral Cable	
Cable Length	10 ft	3 m	
Cable Termination	Blunt cut	Blunt cut	
Electrical Connection Position	Top	Top	
Cable Type	Polyurethane (Model 052)	Polyurethane (Model 052)	

OPTIONAL VERSIONS

Optional versions have identical specifications and accessories as listed for the standard model except where noted below. More than one option may be used.

EX - Hazardous Area Approval- contact factory for specific approvals

Current Rating	100 mA	100 mA
Hazardous Area Approval	CI, Div 2, Groups A, B, C, D; Ex nL IICT3, AEx nA IICT3	CI, Div 2, Groups A, B, C, D; Ex nL IICT3, AEx nA IICT3
Power Required	10 to 30 VDC	10 to 30 VDC
Relay	10 to 30 VDC, 100 mA	10 to 30 VDC, 100 mA

M - Metric Mount
Optional Accessory: Model M081A61 Mounting Stud 1/4-28 to M6 X 1 (1)

NOTES:

[1]USB Programmable - See configuration sheet supplied with switch for exact setting.
 [2]For sensor and cable exit only, customer is responsible for sealing at cable termination
 [3]See PCB Declaration of Conformance PS096 for details.

SUPPLIED ACCESSORIES:

Model 081A41 Mounting stud 1/4-28 socket head set screw brass tip stainless steel 5/8" long (1)

Entered: LK	Engineer: BAM	Sales: MC	Approved: BAM	Spec Number:
Date: 08/22/2019	Date: 08/22/2019	Date: 08/22/2019	Date: 08/22/2019	41977



All specifications are at room temperature unless otherwise specified.
 In the interest of constant product improvement, we reserve the right to change specifications without notice.

IMI SENSORS
 A PCB PIEZOTRONICS DIV.
 3425 Walden Avenue, Depew, NY 14043

Phone: 800-959-4464
Fax: 716-684-3823
E-Mail: imi@pcb.com

PCB Piezotronics Inc. claims proprietary rights in the information disclosed hereon. Neither it nor any reproduction thereof will be disclosed to others without the written consent of PCB Piezotronics Inc.

REVISIONS

REV	DESCRIPTION	ECO
NR	RELEASED TO DRAFTING	

41979

B

B

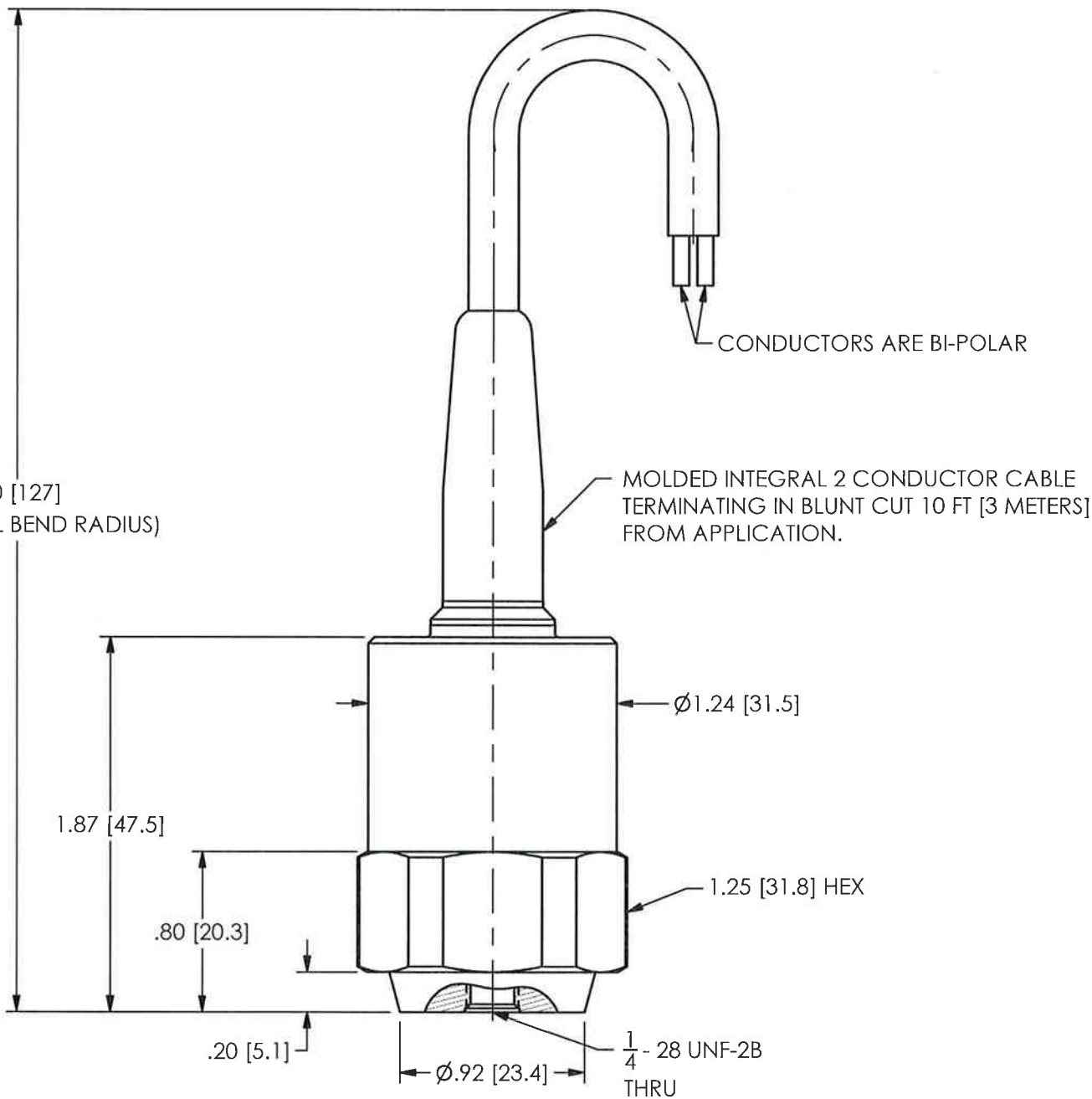

A

A

UNLESS OTHERWISE SPECIFIED TOLERANCES ARE:

DIMENSIONS IN INCHES

DIMENSIONS IN MILLIMETERS [IN BRACKETS]

DECIMALS XX ±.03
XXX ±.010

DECIMALS X ±0.8
XX ±0.25

ANGLES ± 2 DEGREES

ANGLES ± 2 DEGREES

FILLETS AND RADII
.003 - .005

FILLETS AND RADII
[0.07 - 0.13]

DRAWN	<i>ECB</i>	<i>2/10/09</i>	MFG	<i>JR</i>	<i>2/25/09</i>
CHK'D	<i>ECB</i>	<i>2/20/09</i>	ENGR	<i>DORI</i>	<i>2/10/09</i>
APP'D	<i>NR</i>	<i>2/25/09</i>	SALES	<i>EG</i>	<i>2/25/09</i>

TITLE
OUTLINE DRAWING
MODEL 686B1X
VIBRATION SWITCH



3425 WALDEN AVE. DEPEW, NY 14043
(716) 684-0001 E-MAIL: sales@pcb.com

CODE IDENT. NO. 52681	DWG. NO. 41979
SCALE: 1.25X	SHEET 1 OF 1