



**Model 685B0000A33**

**Electronic vibration switch, internal ICP® accel., 0-1.5 ips, AC powered, 5A triac relays, std enclosure plus external BNC jack, one port with 1/2" NPT conduit hub**

**Installation and Operating Manual**

**For assistance with the operation of this product,  
contact the PCB Piezotronics, Inc.**

**Toll-free: 800-959-4464  
24-hour SensorLine: 716-684-0001  
Fax: 716-684-3823  
E-mail: [imi@pcb.com](mailto:imi@pcb.com)  
Web: [www.imi-sensors.com](http://www.imi-sensors.com)**



## Repair and Maintenance

PCB guarantees Total Customer Satisfaction through its “Lifetime Warranty Plus” on all Platinum Stock Products sold by PCB and through its limited warranties on all other PCB Stock, Standard and Special products. Due to the sophisticated nature of our sensors and associated instrumentation, **field servicing and repair is not recommended and, if attempted, will void the factory warranty.**

Beyond routine calibration and battery replacements where applicable, our products require no user maintenance. Clean electrical connectors, housings, and mounting surfaces with solutions and techniques that will not harm the material of construction. Observe caution when using liquids near devices that are not hermetically sealed. Such devices should only be wiped with a dampened cloth—never saturated or submerged.

In the event that equipment becomes damaged or ceases to operate, our Application Engineers are here to support your troubleshooting efforts 24 hours a day, 7 days a week. Call or email with model and serial number as well as a brief description of the problem.

## Calibration

Routine calibration of sensors and associated instrumentation is necessary to maintain measurement accuracy. We recommend calibrating on an annual basis, after exposure to any extreme environmental influence, or prior to any critical test.

PCB Piezotronics is an ISO-9001 certified company whose calibration services are accredited by A2LA to ISO/IEC 17025, with full traceability to SI through N.I.S.T. In addition to our standard calibration services, we also offer specialized tests, including: sensitivity at elevated or cryogenic temperatures, phase response, extended high or low frequency response, extended range, leak testing, hydrostatic pressure testing, and others. For more information, contact your local PCB Piezotronics distributor, sales representative, or factory customer service representative.

## Returning Equipment

If factory repair is required, our representatives will provide you with a Return Material Authorization (RMA) number, which we use to reference any information you have already provided and expedite the repair process. This number should be clearly marked on the outside of all returned package(s) and on any packing list(s) accompanying the shipment.

## Contact Information

PCB Piezotronics, Inc.  
3425 Walden Ave.  
Depew, NY14043 USA  
Toll-free: (800) 828-8840  
24-hour SensorLine: (716) 684-0001  
General inquiries: [info@pcb.com](mailto:info@pcb.com)  
Repair inquiries: [rma@pcb.com](mailto:rma@pcb.com)

For a complete list of distributors, global offices and sales representatives, visit our website, [www.pcb.com](http://www.pcb.com).

## Safety Considerations

This product is intended for use by qualified personnel who recognize shock hazards and are familiar with the precautions required to avoid injury. While our equipment is designed with user safety in mind, the protection provided by the equipment may be impaired if equipment is used in a manner not specified by this manual.

Discontinue use and contact our 24-Hour Sensorline if:

- Assistance is needed to safely operate equipment
- Damage is visible or suspected
- Equipment fails or malfunctions

For complete equipment ratings, refer to the enclosed specification sheet for your product.

## Definition of Terms and Symbols

The following symbols may be used in this manual:



### DANGER

Indicates an immediate hazardous situation, which, if not avoided, may result in death or serious injury.

**CAUTION**

Refers to hazards that could damage the instrument.

**NOTE**

Indicates tips, recommendations and important information. The notes simplify processes and contain additional information on particular operating steps.

**The following symbols may be found on the equipment described in this manual:**



This symbol on the unit indicates that high voltage may be present. Use standard safety precautions to avoid personal contact with this voltage.



This symbol on the unit indicates that the user should refer to the operating instructions located in the manual.



This symbol indicates safety, earth ground.



PCB工业监视和测量设备 - 中国RoHS2公布表

PCB Industrial Monitoring and Measuring Equipment - China RoHS 2 Disclosure Table

| 部件名称   | 有害物质   |        |        |              |            |              |
|--|--------|--------|--------|--------------|------------|--------------|
|  | 铅 (Pb) | 汞 (Hg) | 镉 (Cd) | 六价铬 (Cr(VI)) | 多溴联苯 (PBB) | 多溴二苯醚 (PBDE) |
| 住房   | 0      | 0      | 0      | 0            | 0          | 0            |
| PCB板   | X      | 0      | 0      | 0            | 0          | 0            |
| 电气连接器  | 0      | 0      | 0      | 0            | 0          | 0            |
| 压电晶体   | X      | 0      | 0      | 0            | 0          | 0            |
| 环氧   | 0      | 0      | 0      | 0            | 0          | 0            |
| 铁氟龙  | 0      | 0      | 0      | 0            | 0          | 0            |
| 电子   | 0      | 0      | 0      | 0            | 0          | 0            |
| 厚膜基板   | 0      | 0      | X      | 0            | 0          | 0            |
| 电线   | 0      | 0      | 0      | 0            | 0          | 0            |
| 电缆   | X      | 0      | 0      | 0            | 0          | 0            |
| 塑料   | 0      | 0      | 0      | 0            | 0          | 0            |
| 焊接   | X      | 0      | 0      | 0            | 0          | 0            |
| 铜合金/黄铜   | X      | 0      | 0      | 0            | 0          | 0            |
| 本表格依据 SJ/T 11364 的规定编制。                          |        |        |        |              |            |              |
| 0：表示该有害物质在该部件所有均质材料中的含量均在 GB/T 26572 规定的限量要求以下。  |        |        |        |              |            |              |
| X：表示该有害物质至少在该部件的某一均质材料中的含量超出 GB/T 26572 规定的限量要求。 |        |        |        |              |            |              |
| 铅是欧洲RoHS指令2011/65/ EU附件三和附件四目前由于允许的豁免。           |        |        |        |              |            |              |

CHINA RoHS COMPLIANCE

| Component Name         | Hazardous Substances |              |              |                                |                                |                                       |
|------------------------|----------------------|--------------|--------------|--------------------------------|--------------------------------|---------------------------------------|
|                        | Lead (Pb)            | Mercury (Hg) | Cadmium (Cd) | Chromium VI Compounds (Cr(VI)) | Polybrominated Biphenyls (PBB) | Polybrominated Diphenyl Ethers (PBDE) |
| Housing                | O                    | O            | O            | O                              | O                              | O                                     |
| PCB Board              | X                    | O            | O            | O                              | O                              | O                                     |
| Electrical Connectors  | O                    | O            | O            | O                              | O                              | O                                     |
| Piezoelectric Crystals | X                    | O            | O            | O                              | O                              | O                                     |
| Epoxy                  | O                    | O            | O            | O                              | O                              | O                                     |
| Teflon                 | O                    | O            | O            | O                              | O                              | O                                     |
| Electronics            | O                    | O            | O            | O                              | O                              | O                                     |
| Thick Film Substrate   | O                    | O            | X            | O                              | O                              | O                                     |
| Wires                  | O                    | O            | O            | O                              | O                              | O                                     |
| Cables                 | X                    | O            | O            | O                              | O                              | O                                     |
| Plastic                | O                    | O            | O            | O                              | O                              | O                                     |
| Solder                 | X                    | O            | O            | O                              | O                              | O                                     |
| Copper Alloy/Brass     | X                    | O            | O            | O                              | O                              | O                                     |

This table is prepared in accordance with the provisions of SJ/T 11364.

O: Indicates that said hazardous substance contained in all of the homogeneous materials for this part is below the limit requirement of GB/T 26572.

X: Indicates that said hazardous substance contained in at least one of the homogeneous materials for this part is above the limit requirement of GB/T 26572.

Lead is present due to allowed exemption in Annex III or Annex IV of the European RoHS Directive 2011/65/EU.

**685B-Series Electronic Vibration Switch**

---

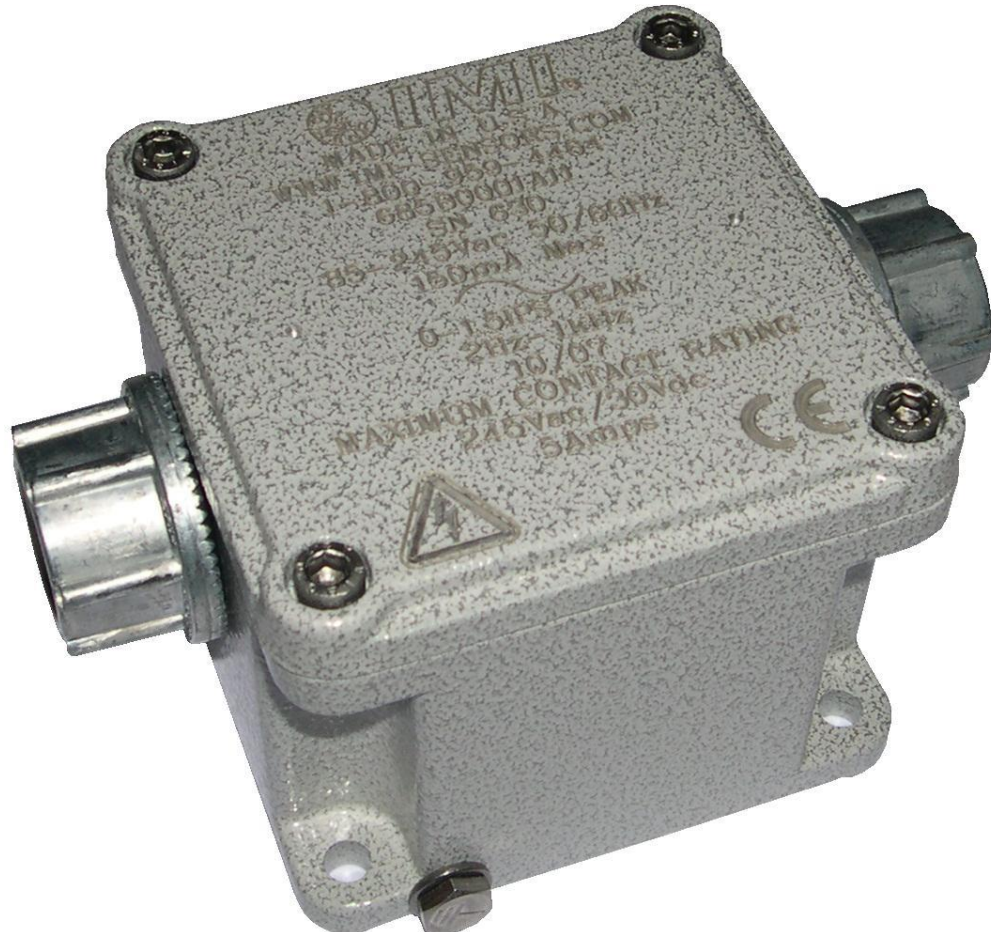

***Operating Guide with Enclosed Warranty Information***

---

**3425 Walden Avenue, Depew, New York 14043-2495**

**Phone (716) 684-0003**

**Fax (716) 684-3823**

**Toll Free Line 1-800-959-4IMI**

MANUAL NUMBER: 34181  
MANUAL REVISION: **H**  
ECO# **47640**

## Table of Contents

---

|   |         |
|---|---------|
| Introduction.....   | Page 3  |
| General Features  |         |
| Specifications .....  | Page 4  |
| Installation and Wiring .....   | Page 5  |
| Installation & Dimensional Drawings   |         |
| Pin Location Diagram- Models with Internal Accelerometer and Triac Relays             |         |
| Pin Location Diagram- Models with Internal Accelerometer and Electromechanical Relays |         |
| Pin Location Diagram- Models with External Accelerometer and Triac Relays             |         |
| Pin Location Diagram- Models with External Accelerometer and Electromechanical Relays |         |
| Configuring the 685B.....   | Page 11 |
| Internal Diagram- Models with Triac Relays  |         |
| Internal Diagram- Models with Electromechanical Relays                                |         |
| Using Calibration Mode  |         |
| Connecting the Remote Reset   |         |
| Connecting the Raw Vibration Output   |         |
| Optional Accessories.....   | Page 14 |
| 080A209 Adapter Plate   |         |
| 699A05 Portable 4-20 mA Calibrator  |         |
| ESD Sensitivity.....  | Page 16 |
| Ordering Information/ Model Matrix .....  | Page 17 |

## Introduction

The 685B-Series is an electronic vibration switch designed to monitor vibration levels and trip an alert when a specified limit is exceeded. A second onboard relay trips an alarm that can be used to shut down a piece of equipment or act as a secondary alert level. An onboard accelerometer with precision electronics insures reliability and accuracy.

### General Features

- Embedded or external piezoelectric accelerometer for improved accuracy and frequency response.
- Vibration range can be measured in acceleration, velocity or displacement (factory set).
- Provides dual 5 Amp Triac (SPST) or 10 Amp Form C (SPDT) relay outputs.
- Adjustable trip limits and time delay via single turn potentiometers.
- Accommodates normally open (NO) and normally closed (NC) wiring schemes.
- Continuous or latching switch action.
- Local reset button and remote reset capability.
- LED indicators for power, alert and alarm.
- Screw terminal blocks for easy wiring.
- Mounts directly to the equipment being monitored via four bolt pattern.
- Flexible design allows for various custom requirements.
- 4-20 mA field calibration feature for improved accuracy.
- Raw vibration & 4-20 mA outputs as standard.



## Specifications

- **Power Supply Voltage:** ..... 85-240 VAC, 12-30 VDC (factory set)
- **Power Supply Current:** ..... 150 mA max
- **Sensor Type:** ..... Piezoelectric Sensing Element
- **Standard Vibration Ranges:** ..... 0-5g pk, 0-1.5 ips pk, 0-3 ips pk, 0-50 mils pk-pk, 0-15 mils pk-pk (factory set)
- **Frequency Response +/-3dB:** ..... 2Hz to 1Khz (120 – 60,000cpm)
- **Turn on Time Delay:** ..... 20 seconds
- **Alert/Alarm Time Delay:** ..... 0-45 seconds
- **Alert/Alarm Function Select:** ..... Latch or Continuous
- **Alert/Alarm Switches:** ..... 5A/245Vac Triac (SPST) or 10A/245Vac – 5A/30Vdc Form C Relay (SPDT)
- **Operating Temperature Range:** ..... -22 to 158°F (-30 to 70°C)
- **Storage Temperature Range:** ..... -40 to 257°F (-40 to 125°C)
- **Relative Humidity:**..... NEMA 4X Rating
- **Case Dimension W x H x D:** ..... 3.5 x 2.8 x 3.5in. (90 x 70 x 90mm)
- **Weight:** ..... 1.85 lbs. (839 grams)
- **Case Material:** ..... Aluminum Alloy
- **Input/Output Electrical Connectors:** ..... Screw Terminals
- **Screw Terminal Wire Size:** ..... 24-14 AWG (0.2-2.5 mm<sup>2</sup>)
- **Wiring Interface:** ..... Cord Grips (wire comp. dia. 0.2”- 0.35”) or ½” NPT Conduit Hubs
- **Mounting Hole Size:** ..... 0.21 inches
- **Mounting Screw Torque:** ..... 2- 5 ft. lbs. (3-7Nm)
- **LED Indicators:**
  - Power: - Green
  - Alarm: - Red
  - Alert: - Yellow
- **Alert/ Alarm Setpoint:** ..... Single Turn Potentiometer (10-100% Full Scale Range)
- **Reset Function:** ..... Momentary Pushbutton Switch and/or Remote to Common.

## Installation and Wiring

### Installation

The 685B-Series is designed to be mounted directly on the equipment to be monitored using a four-bolt pattern. There are also options to retrofit existing 3 bolt pattern installations. (Model 080A209 mounting plate required- see optional accessories on page 13). Use grease between all surfaces to insure specified frequency response, otherwise performance will be degraded. The axis of vibration measured by models with internal accelerometers is perpendicular to the mounting orientation of the unit.

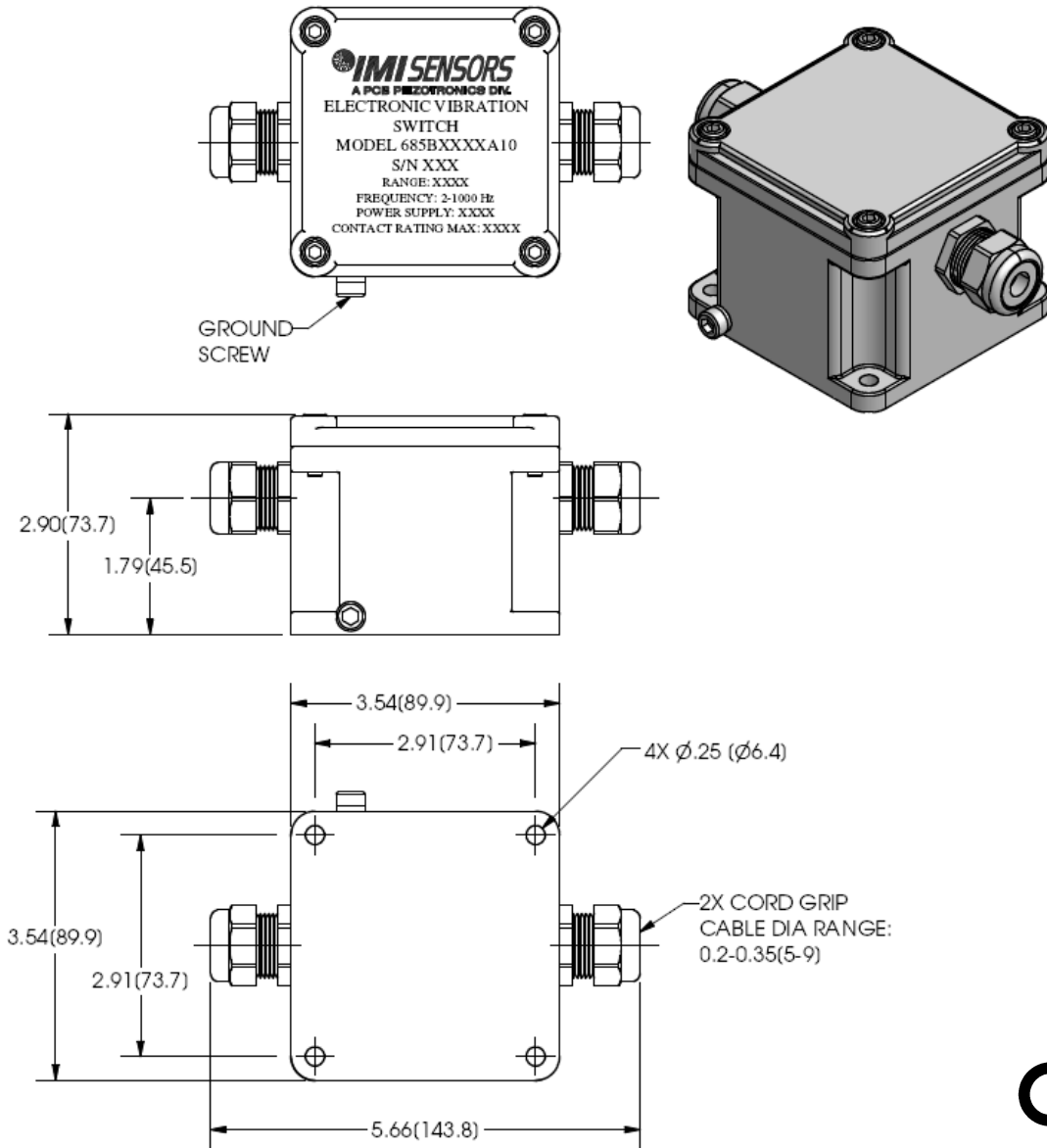

**Standard Model Dimension Drawing with Cord Grips**

Inch (mm)



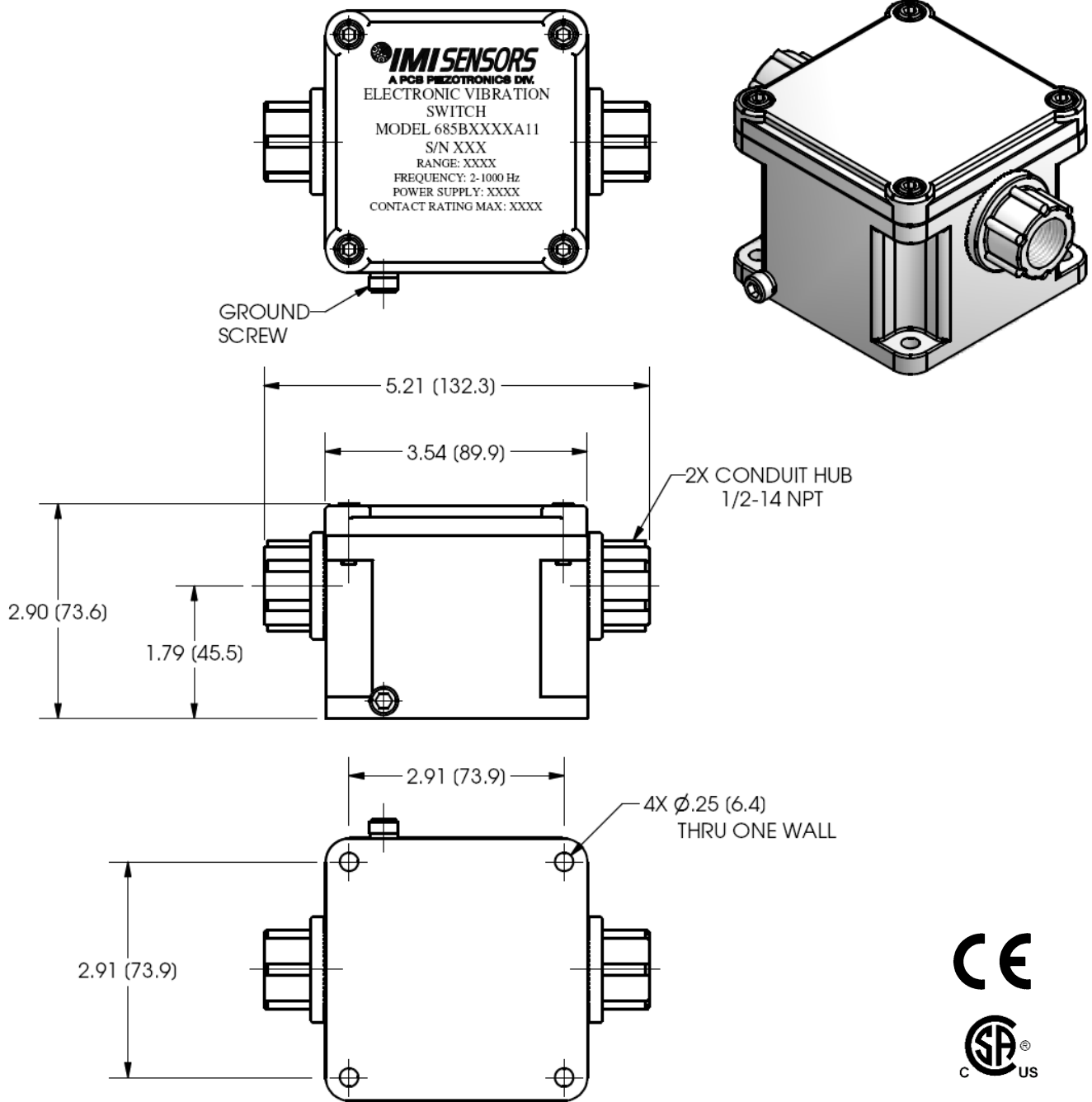

**Standard Model Dimension Drawing with 1/2" NPT Conduit Hubs**  
Inch (mm)



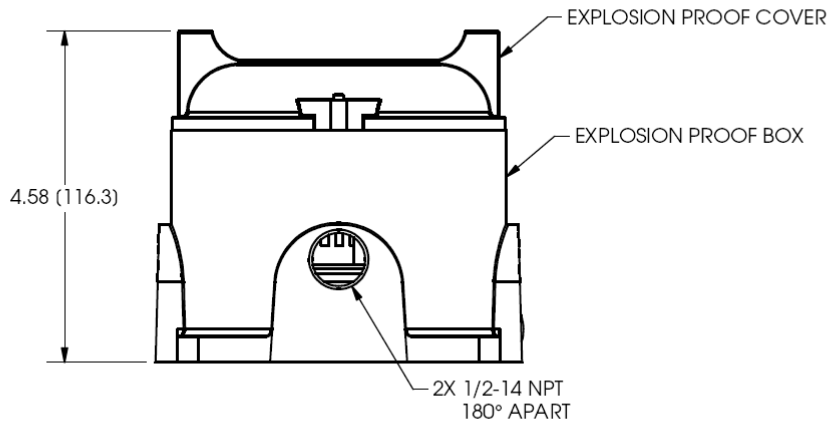
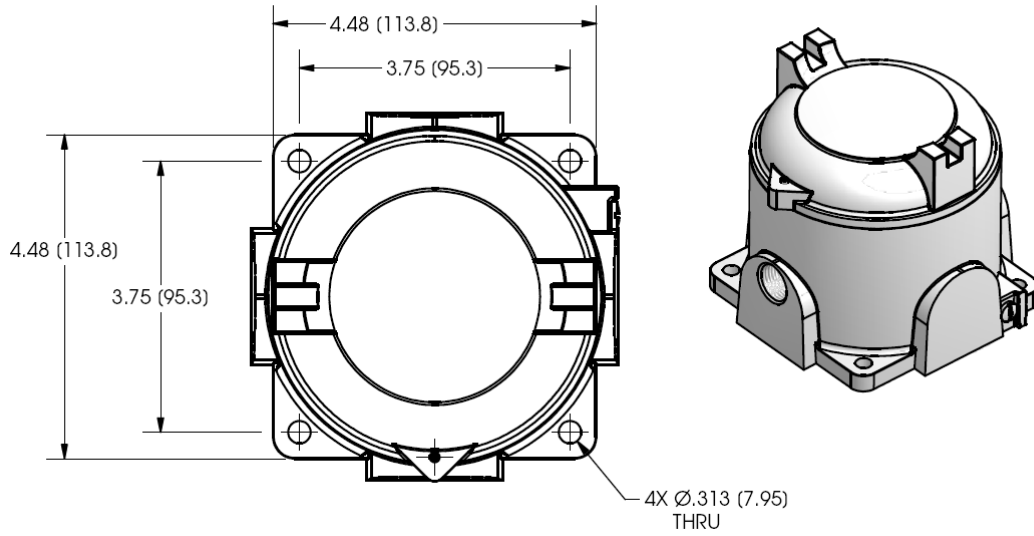

**Explosion Proof Model Dimension Drawing**  
Inch (mm)



**WARNING**

**AC and DC input signals and power supply voltages could be hazardous. DO NOT connect live wires to screw terminal plugs, and DO NOT insert, remove, or handle screw terminal plugs with live wires connected.**

## Connector and Pinout Diagram

The 685B-Series uses screw terminal connectors for all input and output connections.

Strip off 0.3" (8mm) of insulation from the connection wire ends. Feed the wire through the access ports, and terminate the wire in the correct location. Once connected, tug lightly on the wire to confirm connection is secure.

### Pin Location Diagram- Models with Internal Accelerometer and Triac Relays

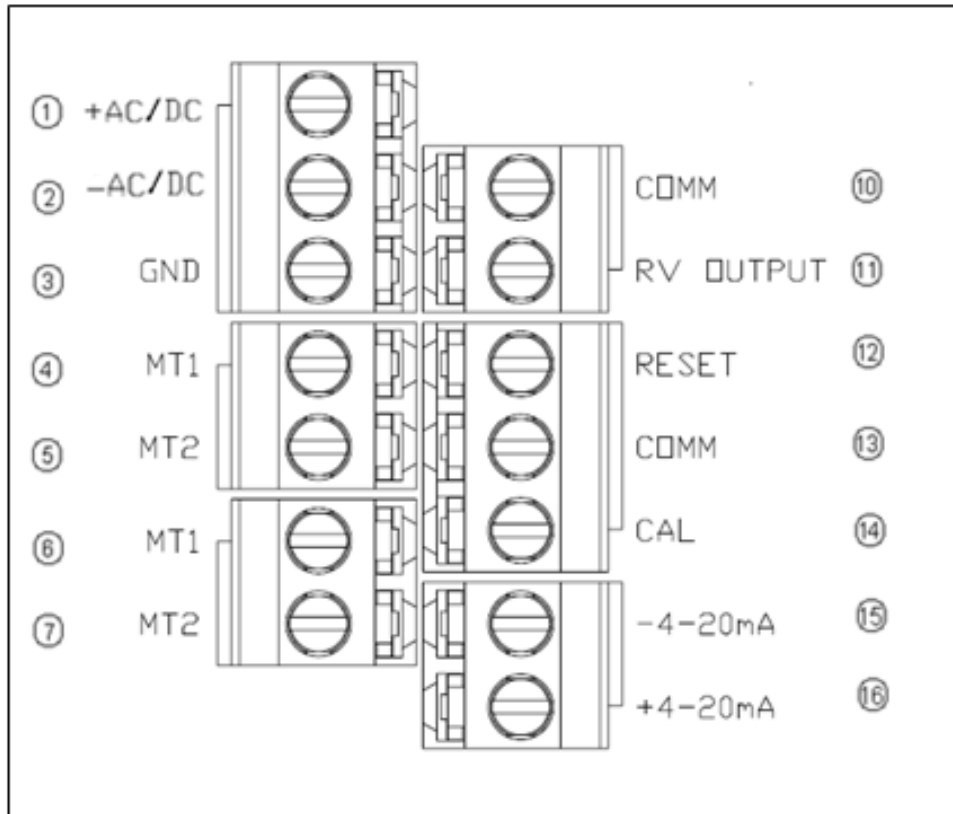

| Pin | Category               | Description   |
|-----|------------------------|---|
| 1   | AC Power               | + Power   |
| 2   |                        | - Power/Common                                      |
| 3   |                        | Earth Ground (Also connect to enclosure safety lug) |
| 4   | Alarm Output           | Main Terminal 1                                     |
| 5   |                        | Main Terminal 2                                     |
| 6   | Alert Output           | Main Terminal 1                                     |
| 7   |                        | Main Terminal 2                                     |
| 8   | N/A                    | N/A   |
| 9   |                        | N/A   |
| 10  | Raw Vibration Output   | Common  |
| 11  |                        | +Signal   |
| 12  | Control Configurations | Remote Reset Connection (Do not apply power)        |
| 13  |                        | Common Connection                                   |
| 14  |                        | Calibration Connection                              |
| 15  | Current Output         | - 4-20 mA   |
| 16  |                        | + 4-20 mA   |

### Pin Location Diagram- Models with Internal Accelerometer and Electromechanical Relays

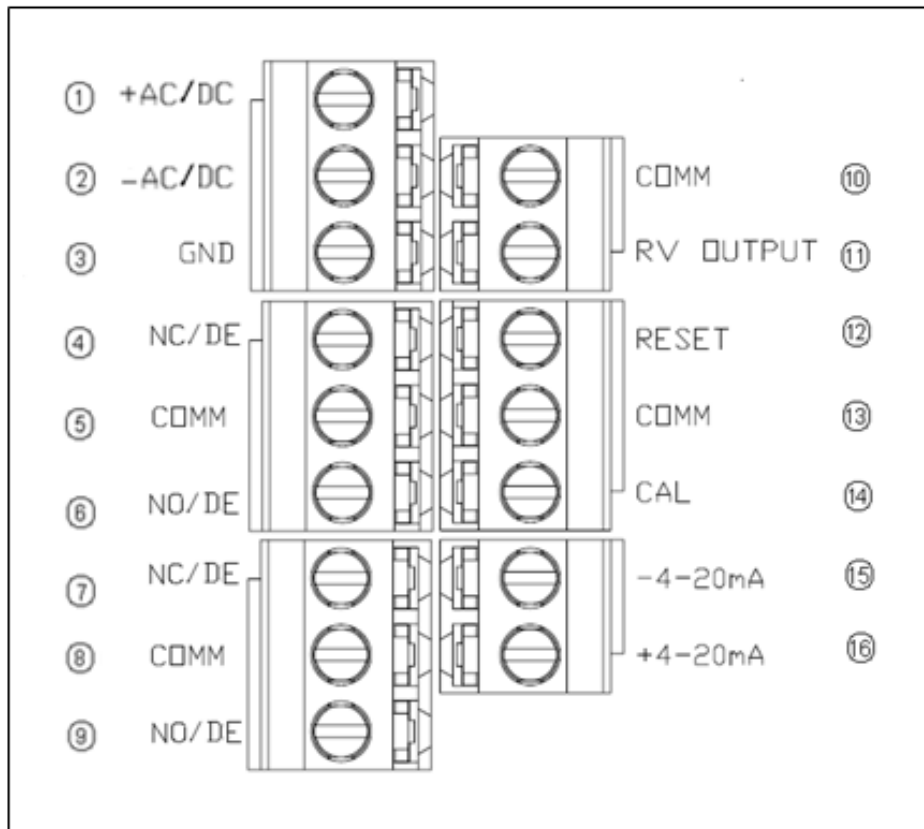

| Pin | Category               | Description  |
|-----|------------------------|--|
| 1   | AC Power               | + Power  |
| 2   |                        | - Power/Common   |
| 3   |                        | Earth Ground (Also connect to enclosure safety lug)          |
| 4   | Alarm Output           | Normally Closed (when dipswitch is in de-energized position) |
| 5   |                        | Common connection  |
| 6   |                        | Normally Open (when dipswitch is in de-energized position)   |
| 7   | Alert Output           | Normally Closed (when dipswitch is in de-energized position) |
| 8   |                        | Common connection  |
| 9   |                        | Normally Open (when dipswitch is in de-energized position)   |
| 10  | Raw Vibration Output   | Common   |
| 11  |                        | +Signal  |
| 12  | Control Configurations | Remote Reset Connection (Do not apply power)                 |
| 13  |                        | Common Connection  |
| 14  |                        | Calibration Connection                                       |
| 15  | Current Output         | - 4-20 mA  |
| 16  |                        | + 4-20 mA  |

### Pin Location Diagram- Models with External Accelerometer and Triac Relays

When the external 100mV/g ICP® sensor option is specified, an additional terminal block location is added to the 685B-Series. The external accelerometer is connected to +Sensor and –Sensor positions as indicated in the above figure and on the product label locate inside the top cover. The cable shield to the accelerometer should be grounded as required by local codes as well as to limit RFI/EMI interference.

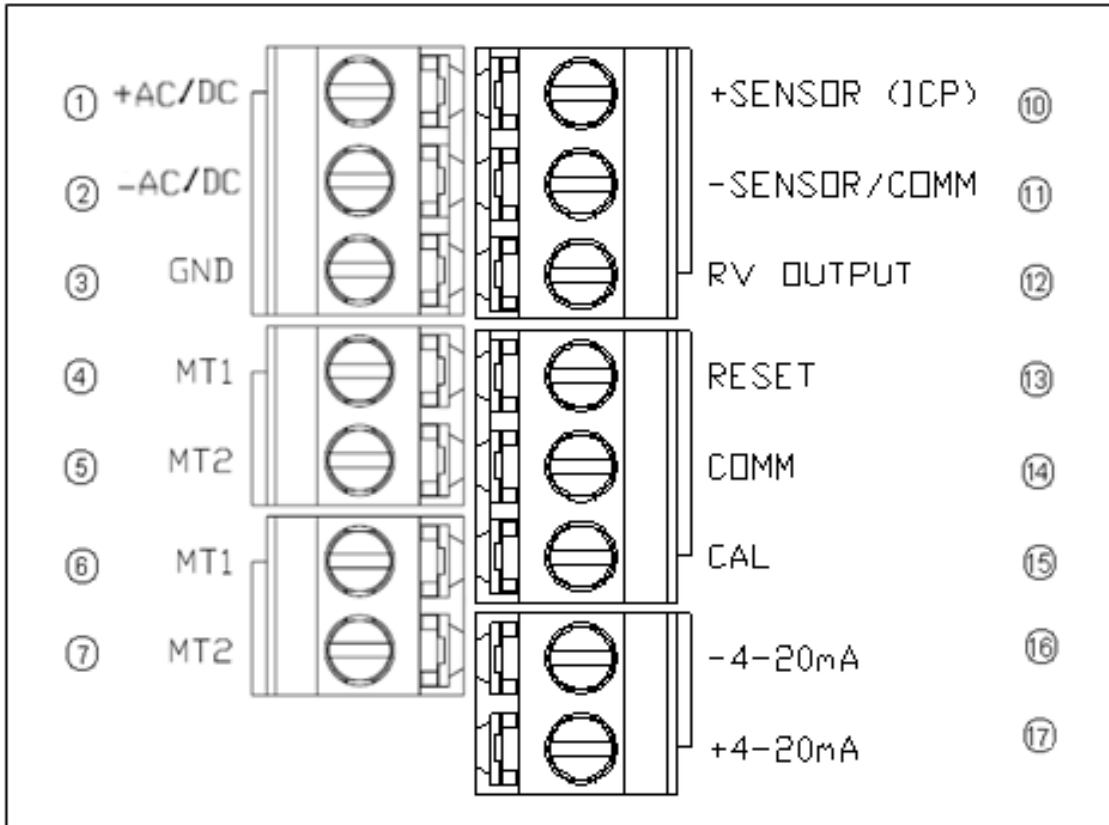

| Pin | Category                            | Description   |
|-----|-------------------------------------|---|
| 1   | AC Power                            | + Power   |
| 2   |                                     | - Power/Common                                      |
| 3   |                                     | Earth Ground (Also connect to enclosure safety lug) |
| 4   | Alarm Output                        | Main Terminal 1                                     |
| 5   |                                     | Main Terminal 2                                     |
| 6   | Alert Output                        | Main Terminal 1                                     |
| 7   |                                     | Main Terminal 2                                     |
| 8   | N/A                                 | N/A   |
| 9   |                                     | N/A   |
| 10  | Sensor Input & Raw Vibration Output | + Sensor  |
| 11  |                                     | - Sensor/Common                                     |
| 12  |                                     | +Signal   |
| 13  | Control Configurations              | Remote Reset Connection (Do not apply power)        |
| 14  |                                     | Common Connection                                   |
| 15  |                                     | Calibration Connection                              |
| 16  | Current Output                      | - 4-20 mA   |
| 17  |                                     | + 4-20 mA   |

## Pin Location Diagram- Models with External Accelerometer and Electromechanical Relays

When the external 100mV/g ICP® Sensor option is specified, an additional terminal block location is added to the 685B-Series. The external accelerometer is connected to +Sensor and –Sensor positions as indicated in the above figure and on the product label locate inside the top cover. The cable shield to the accelerometer should be grounded as required by local codes as well as to limit RFI/EMI interference.

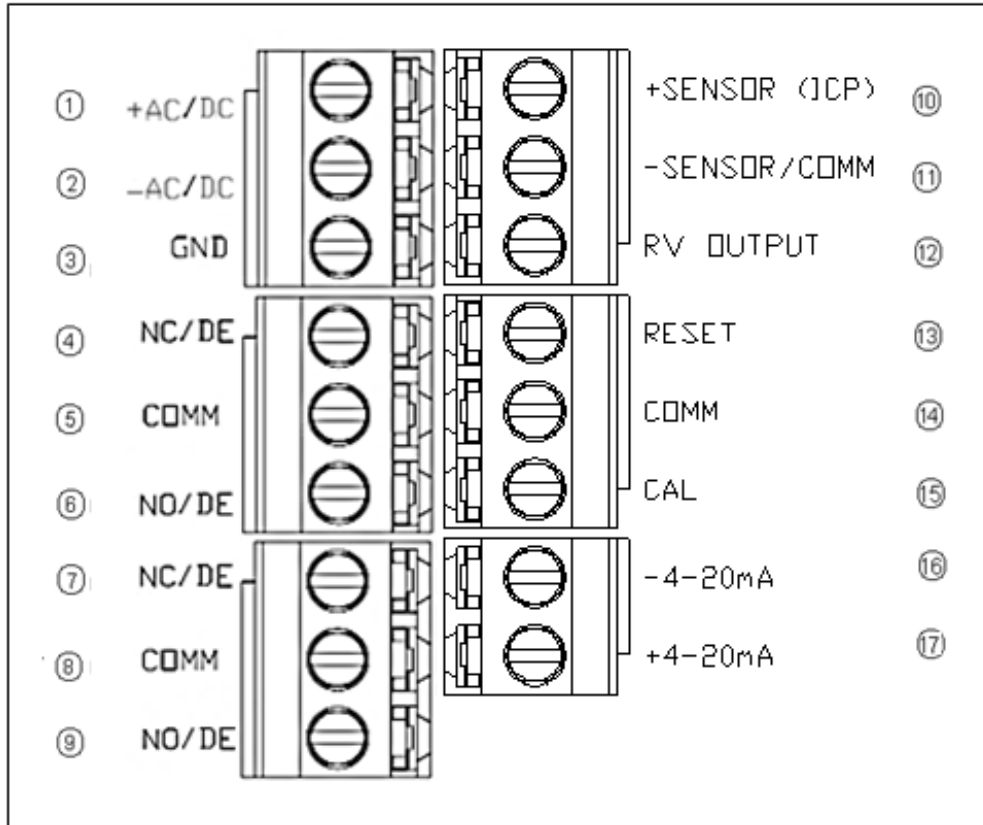

| Pin | Category                            | Description  |
|-----|-------------------------------------|--|
| 1   | AC Power                            | + Power  |
| 2   |                                     | - Power/Common   |
| 3   |                                     | Earth Ground (Also connect to enclosure safety lug)          |
| 4   | Alarm Output                        | Normally Closed (when dipswitch is in de-energized position) |
| 5   |                                     | Common connection  |
| 6   |                                     | Normally Open (when dipswitch is in de-energized position)   |
| 7   | Alert Output                        | Normally Closed (when dipswitch is in de-energized position) |
| 8   |                                     | Common connection  |
| 9   |                                     | Normally Open (when dipswitch is in de-energized position)   |
| 10  | Sensor Input & Raw Vibration Output | + Sensor   |
| 11  |                                     | - Sensor/Common  |
| 12  |                                     | +Signal  |
| 13  | Control Configurations              | Remote Reset Connection (Do not apply power)                 |
| 14  |                                     | Common Connection  |
| 15  |                                     | Calibration Connection                                       |
| 16  | Current Output                      | - 4-20 mA  |
| 17  |                                     | + 4-20 mA  |



## Configuring the 685B-Series

Internal Diagram- Models with Triac Relays

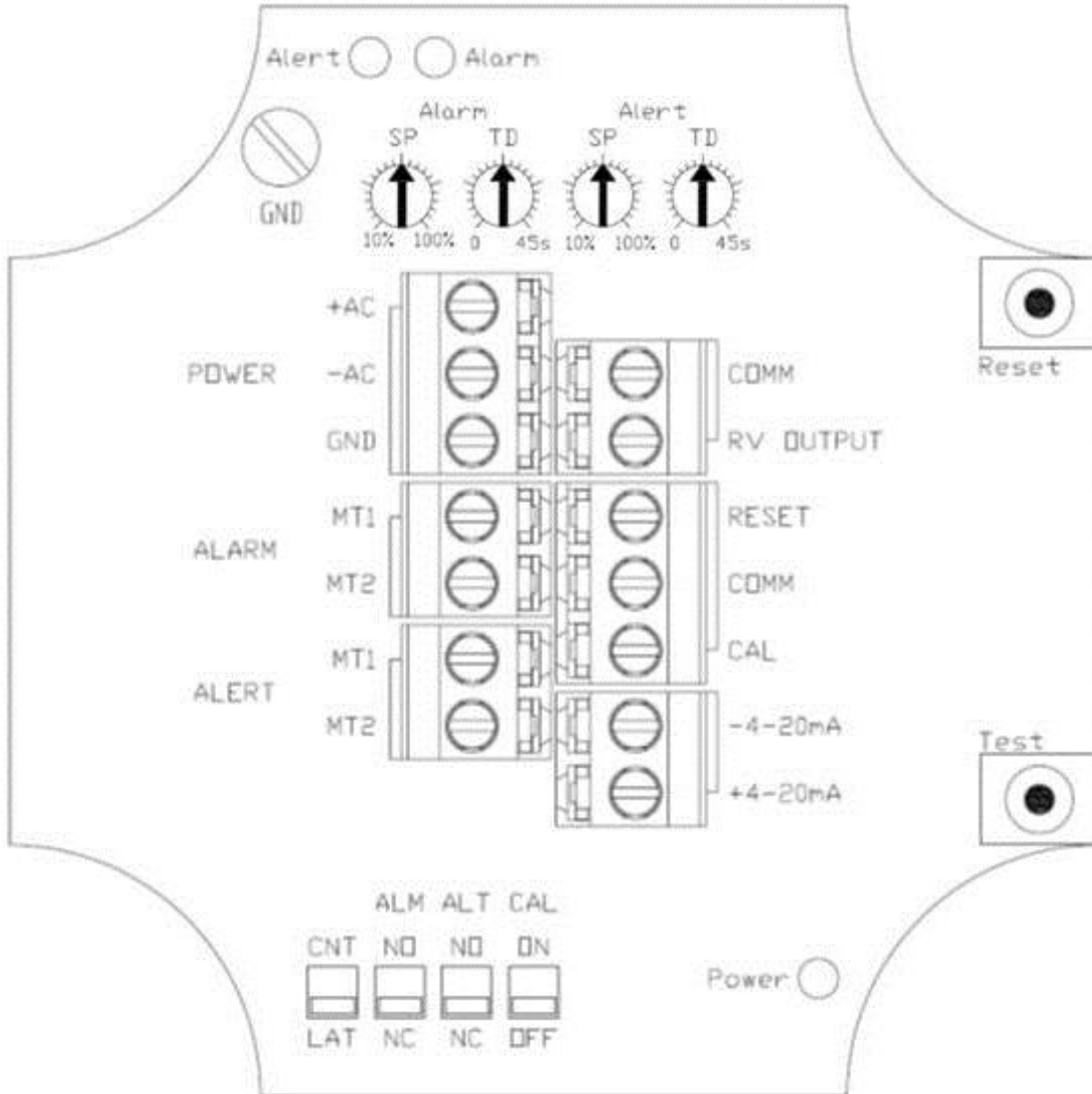

The internal diagram displays the location of the control features for the triac versions of the 685B-Series. The alert and alarm set points are adjusted via the single turn potentiometers. The alarm relay is set using the first potentiometer, and the alert relay is set using the third. The alert relay trips when the set percentage of the alarm value is reached. Time delays for both functions are controlled using the second and fourth potentiometers. Alert and alarm relays can be reset remotely by using the RESET and COMM pins or by using the internal reset switch as seen on the upper right hand corner of the diagram.

Using the dipswitches beneath the terminal connectors, relay operation can be selected to be either latch or continuous, and each relay can be separately configured to be normally open (de-energized) or normally closed (energized). There is also a dipswitch to activate the **calibration mode** for condition simulation during the setup process. This is explained in detail on page 13.

## Internal Diagram- Models with Electromechanical Relays

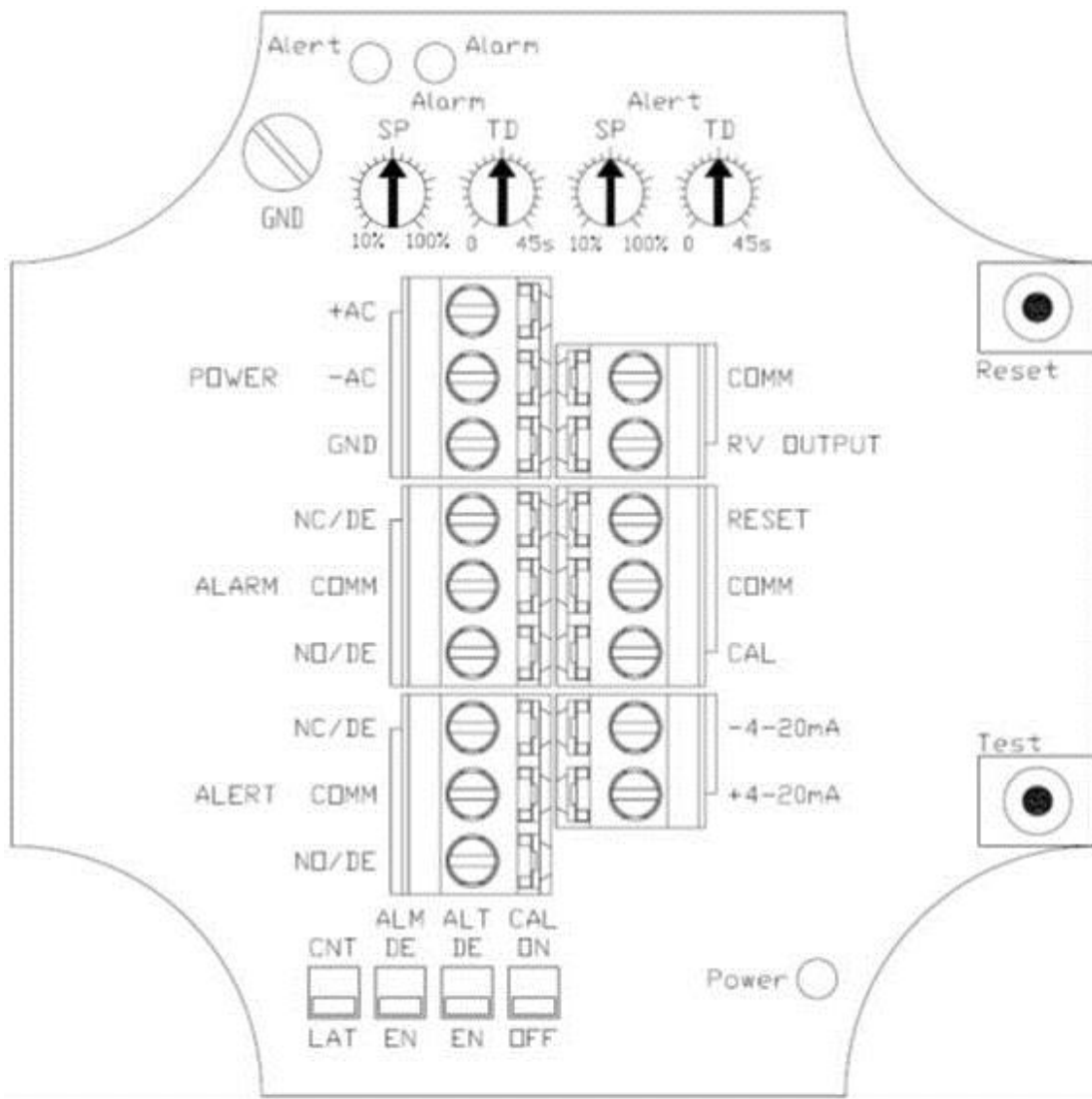

The internal diagram displays the location of the control features for the relay versions of the 685B-Series. The alert and alarm set points are adjusted via the single turn potentiometers. The alarm relay is set using the first potentiometer, and the alert relay is set using the third. The alert relay trips when the set percentage of the alarm value is reached. Time delays for both functions are controlled using the second and fourth potentiometers. Alert and alarm relays can be reset remotely by using the RESET and COMM pins or by using the internal reset switch as seen on the upper right hand corner of the diagram.

Using the first dipswitch beneath the terminal connectors, relay operation can be selected to be either latch or continuous. The second and third dipswitches set the alert and alarm relay configuration to be energized or de-energized. The diagram above indicates the contacts that are normally open and normally closed when the dip switch is set to “de-energized”. When the dipswitch is changed to “energized”, the normally open and normally closed contacts would be reversed. The fourth dipswitch is used to activate the **calibration mode** for condition simulation during the setup process. This is explained in detail on page 12.

## Using Calibration Mode

The 685B-Series has the unique ability to be calibrated using a 4-20 mA simulator. (IMI Sensors model 699A05, see “Accessories” page) This allows for a much more accurate and quantifiable calibration versus manually attuning the switch. The following steps allow for simple calibration using this configuration.

- 1) Connect the 4-20 mA simulator signal across the COMM and CAL pins.
- 2) Turn the calibration dipswitch to “on”. This will disable the switch’s ability to measure physical vibration.
- 3) Turn both time delay potentiometers to “zero” for calibration purposes. This can be adjusted to desired delay after calibration.
- 4) Assume that 4 mA equals zero vibration and 20 mA equals full scale vibration. Then calculate, in mA, the vibration level for which the alert and alarm switches should trip.
- 5) Using the 4-20 mA simulator, send the appropriate alarm signal based on the calculation in the previous step for the alarm signal.
- 6) Adjust the “SP” Alarm set point potentiometer to the point when the red Alarm LED illuminates.
- 7) Using the 4-20 mA simulator, repeat step 5 for the Alert signal.
- 8) Adjust the “SP” Alert set point potentiometer to the point where the yellow Alert LED illuminates. It is important to set the Alarm potentiometer first because the Alert signal acts as a percentage of the value set for Alarm.
- 9) Disconnect the 4-20 mA simulator.
- 10) Turn “off” the calibration dipswitch.

**\*\* Warning: To avoid damage, insure 685B-Series is under power prior to applying the 4-20mA signal from the simulator. \*\***

## Testing the Calibration

Pushing the “Test” button inside the housing simulates full scale vibration and should illuminate both the alert and alarm LED’s. This feature can be used to adjust time delays to the desired values. This can be accurately calculated using the “Test” button and a stopwatch.

## Connecting the Remote Reset

The 685B-Series allows for remote reset when the switch is in latch mode via a short between the RESET and COMM pins.

## Connecting the Raw Vibration Output

All models in the 685B-Series offer the option for obtaining accelerometer’s raw vibration signal. Models with internal accelerometers output 100 mV/g. To obtain this signal using digital analyzer, turn the ICP® power **OFF** at the digital analyzer input. Connect the analyzer to the RV OUTPUT and COMM pins with the common connection on the COMM pin and the signal connection on the RV OUTPUT pin.

**Optional Accessories**

**Model 080A209 Adapter Plate**

*To retrofit old style vibration switch bolt patterns*

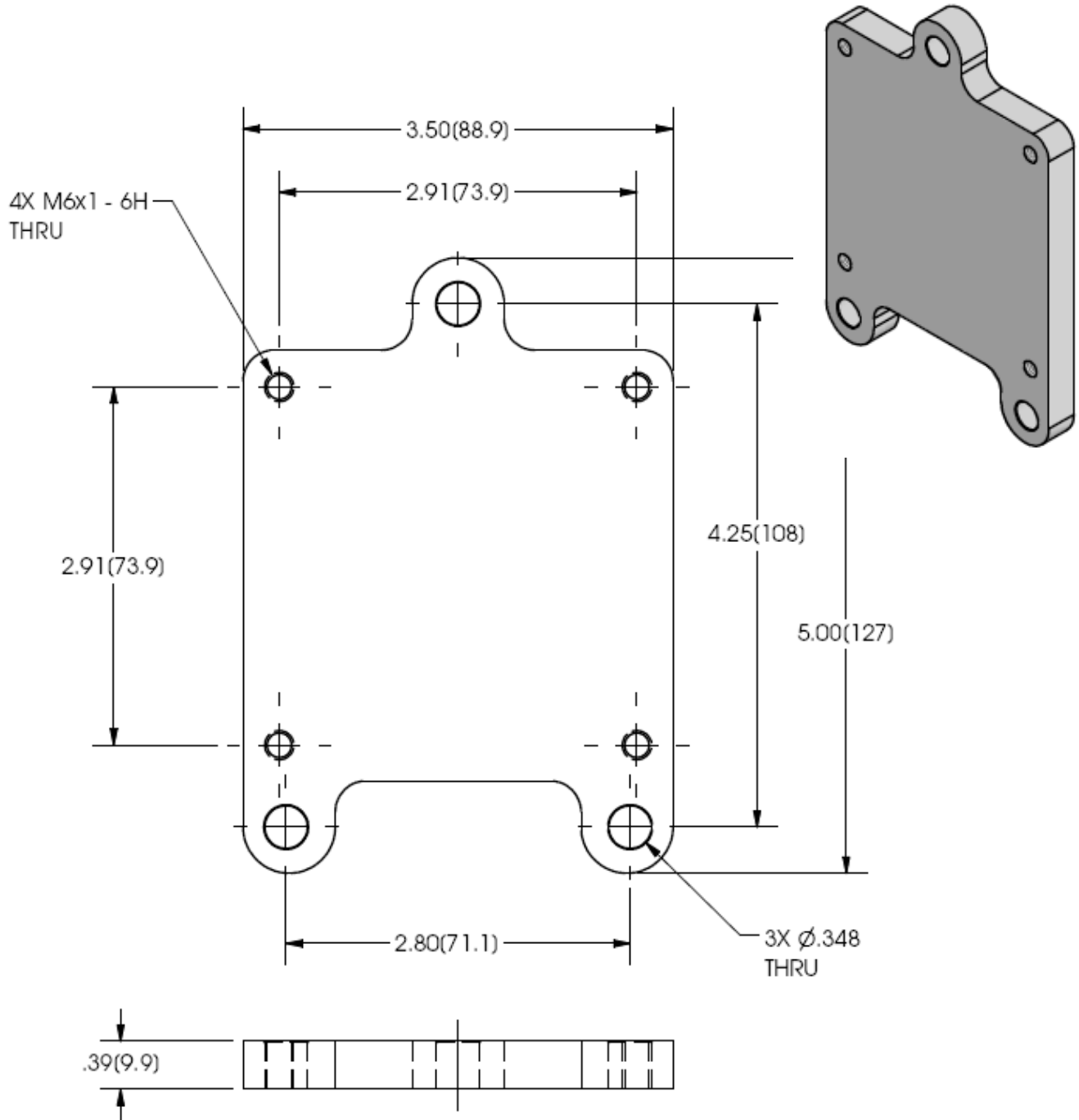

**Model 699A05 Portable 4-20 mA Calibrator**

Provides current output for 685B-Series testing, read-out and calibration purposes. Also receives and displays current signal from 4-20 mA proportional output from the 685B-Series.

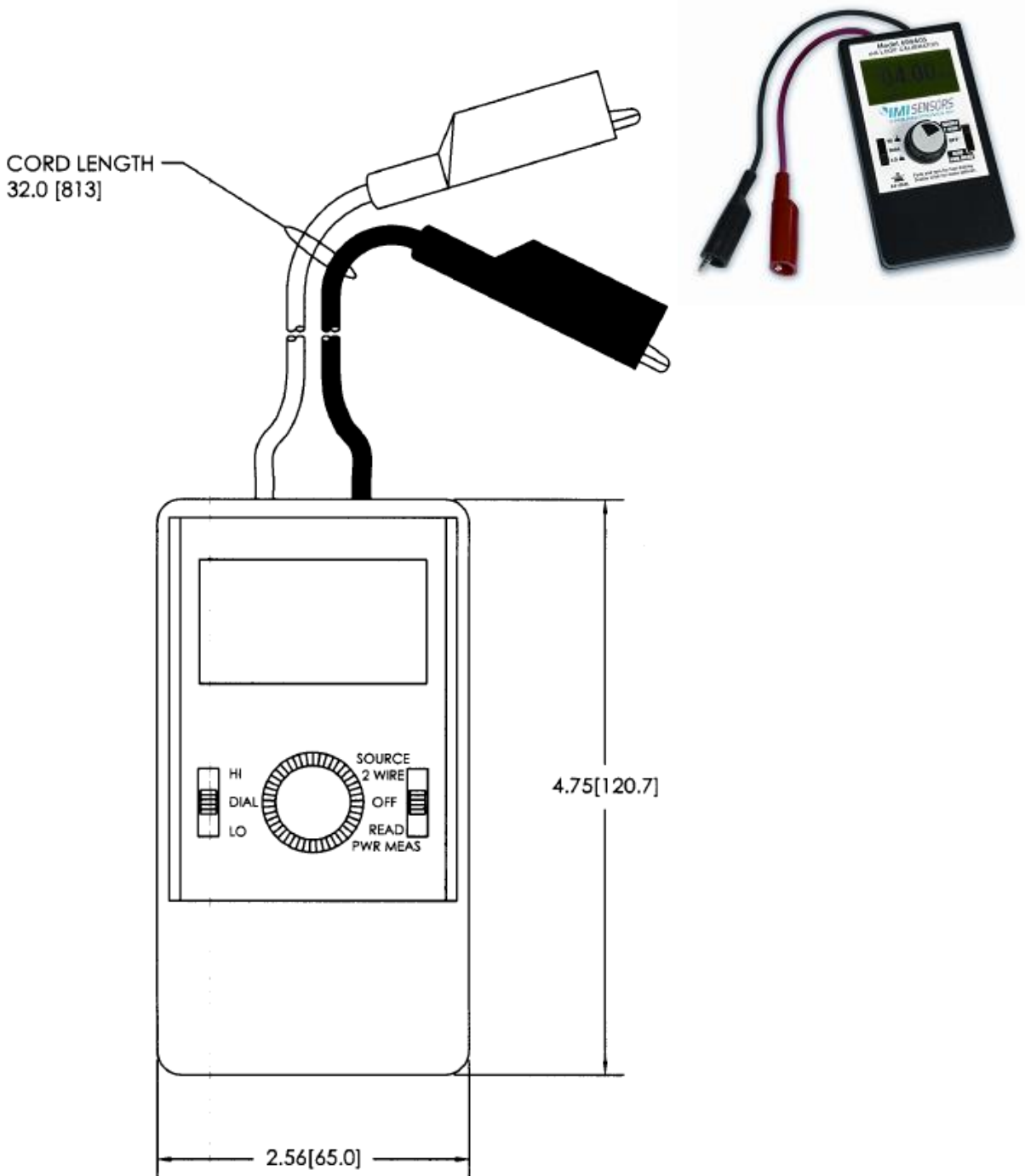

## **Warning 1 – ESD sensitivity**

---

**The power supply/signal conditioner should not be opened by anyone other than qualified service personnel.** This product is intended for use by qualified personnel who recognize shock hazards and are familiar with the safety precautions required to avoid injury.

## **Warning 2 – ESD sensitivity**

---

This equipment is designed with user safety in mind; however, the protection provided by the equipment may be impaired if the equipment is used in a manner not specified by PCB Piezotronics, Inc.

## **Caution 1 – ESD sensitivity**

---

**Cables can kill your equipment.** High voltage electrostatic discharge (ESD) can damage electrical devices. Similar to a capacitor, a cable can hold a charge caused by triboelectric transfer, such as that which occurs in the following:

- *Laying on and moving across a rug,*
- *Any movement through air,*
- *The action of rolling out a cable, and/or*
- *Contact with a non-grounded person.*

### **The PCB solution for product safety:**

- *Connect the cables only with the AC power off.*
- *Temporarily “short” the end of the cable before attaching it to any signal input or output.*

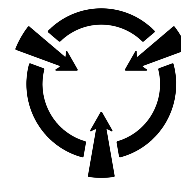

**CAUTION**  
ELECTROSTATIC  
DISCHARGE SENSITIVE

## **Caution 2 – ESD sensitivity**

---

**ESD considerations should be made prior to performing any internal adjustments on the equipment.** Any piece of electronic equipment is vulnerable to ESD when opened for adjustments. Internal adjustments should therefore be done ONLY at an ESD-safe work area. Many products have ESD protection, but the level of protection may be exceeded by extremely high voltage.

## Ordering Information/ Model Matrix

IMI Part Number: **685B** 0 0 0 0 A1 0

**Basic Model Series** \_\_\_\_\_

685B

**Sensor Option** \_\_\_\_\_

- 0 *Internal 100 mV/g ICP Sensor*
- 1 External 100mV/g ICP® Sensor
- 2 External 100 mV/g ICP Sensor (Low Frequency)
- 3 *Internal 100 mV/g ICP Sensor (Low Frequency)*
- 4 External 100mV/g ICP® Sensor (Sensor Fault Detection)
- 5 External 100mV/g ICP® Sensor (Sensor Fault Detection)

**Scale Factor** \_\_\_\_\_

- 0 *0-1.5 in/sec peak*
- 1 *0-5 g peak*
- 2 *0-15 mils peak to peak displacement*
- 3 *0-50 mils peak to peak displacement*
- 4 *0-3.0 in/sec peak*

**Power Required** \_\_\_\_\_

- 0 *85-245 VAC, 50/60 Hz*
- 1 *24 VDC ±10%*

**Relay Type (two provided)** \_\_\_\_\_

- 0 *Triac, 5A/245vac*
- 1 *Form C Relay (SPDT) 10A/245Vac – 5A/30Vdc*

**Enclosure Type/ Hazardous Area Approval** \_\_\_\_\_

- A1 *Basic enclosure, internal pushbutton for remote reset*
- A2 Same as A1, plus external pushbutton for remote reset
- A3 Same as A1, plus acceleration signal through external BNC
- A4 Same as A1, plus A2 & A3
- C1 Explosion Proof Enclosure (must select option 4 connection)

**Connection Interface** \_\_\_\_\_

- 0 Dual openings, cord grips
- 1 *Dual openings, ½" NPT conduit hubs*
- 2 Single opening, cord grip
- 3 *Single opening, ½" NPT conduit hub*
- 4 Dual openings, ½" NPT conduit hubs (for C1 enclosures only)
- 5 Dual openings, cord grip on left, ½" NPT conduit hub on right
- 6 Dual openings, cord grip on right, ½" NPT conduit hub on left

CSA Class I, Division 2 approval is supplied as standard for switches that are NOT using the C1 enclosure but are using all italicized options.

Model Number  
**685BXXXXXX**

# ELECTRONIC VIBRATION SWITCH SPECIFICATIONS

Revision: J  
ECN #: 53981

**DYNAMIC PERFORMANCE**

|                           | <b><u>ENGLISH</u></b>        | <b><u>SI</u></b>             |
|---------------------------|------------------------------|------------------------------|
| Frequency Response (±3dB) | 120 - 60000 cpm              | 2 - 1000 Hz                  |
| Alarm Setpoint            | 10 to100% of Vibration Range | 10 to100% of Vibration Range |
| Alert Setpoint            | 10 to100% of Alarm Setpoint  | 10 to100% of Alarm Setpoint  |
| Alert/Alarm Time Delay    | 0 - 45 sec                   | 0 - 45 sec                   |
| Turn on Time Delay        | 20 sec                       | 20 sec                       |

**ELECTRICAL**

|                             | <b><u>ENGLISH</u></b>         | <b><u>SI</u></b>              |
|-----------------------------|-------------------------------|-------------------------------|
| Power Supply Current        | <150 mA                       | <150 mA                       |
| Sensor Type                 | Piezoelectric Sensing Element | Piezoelectric Sensing Element |
| Output (Current)            | 4 to 20 mA                    | 4 to 20 mA                    |
| Raw Vibration Output (±20%) | 100 mV/g                      | 10.2 mV/(m/s <sup>2</sup> )   |
| Calibration Input           | 4 to 20 mA                    | 4 to 20 mA                    |

**ENVIRONMENTAL**

|                             | <b><u>ENGLISH</u></b> | <b><u>SI</u></b> |
|-----------------------------|-----------------------|------------------|
| Operating Temperature Range | -22 to +158°F         | -30 to +70°C     |
| Storage Temperature Range   | -40 to +257°F         | -40 to +125°C    |
| Relative Humidity           | NEMA 4X               | IP66             |

**MECHANICAL**

|                                    | <b><u>ENGLISH</u></b>    | <b><u>SI</u></b>          |
|------------------------------------|--------------------------|---------------------------|
| Case Dimension W x H x D:          | 3.5 in x 2.8 in x 3.5 in | 90 mm x 70 mm x 90 mm     |
| Weight                             | 1.85 lb                  | 839 gm                    |
| Material                           | Aluminum Alloy           | Aluminum Alloy            |
| Input/Output Electrical Connectors | Screw Terminals          | Screw Terminals           |
| Screw Terminal Wire Size           | 24 – 14 AWG              | 0.2 – 2.5 mm <sup>2</sup> |
| Cover Screw Torque (Maximum)       | 4.1 lb-ft                | 5.7 N-m                   |
| Mounting Hole Size (max. diameter) | 0.21 in                  | 5.4 mm                    |
| Mounting Screw Torque              | 2-5 lb-ft                | 3-7 N-m                   |

**INDICATOR/CONTROLS**

|                                  | <b><u>ENGLISH</u></b>       | <b><u>SI</u></b>            |
|----------------------------------|-----------------------------|-----------------------------|
| Power LED                        | Green                       | Green                       |
| Alarm LED                        | Red                         | Red                         |
| Alert LED                        | Yellow                      | Yellow                      |
| Setpoint Adjustment              | Single Turn Potentiometer   | Single Turn Potentiometer   |
| Time Delay Adjustment            | Single Turn Potentiometer   | Single Turn Potentiometer   |
| Reset Function                   | Momentary Pushbutton Switch | Momentary Pushbutton Switch |
| Self Test Function               | Momentary Pushbutton Switch | Momentary Pushbutton Switch |
| Alarm/Alert Function Select      | Latch or Continuous         | Latch or Continuous         |
| Switch Mechanism Function Select | NO/NC                       | NO/NC                       |

**OPTIONAL VERSIONS**

Optional versions have identical specifications and accessories as listed for the standard model except where noted below. More than one option may be used.

**Accelerometer Configuration: 685BX000000**

0 Internal

1 External ICP Accelerometer (100 mV/g)

2 External ICP Accelerometer (100 mV/g) Low Freq. (1-1000 Hz)

**Vibration Range: 685B0X00000**

0 0 to 1.5 in/s pk (0 to 38.1 mm/s pk)

1 0 to 5 g's pk (0 to 49 m/s<sup>2</sup> pk)

2 0 to 15 mils pk to pk (0 to 381 μm pk to pk)

3 0 to 50 mils pk to pk (0 to 1.27 mm pk to pk)

4 0 to 3.0 in/s pk (0 to 76.2 mm/s pk)

**Input Power: 685B00X0000**

0 85-245 Vac 50/60 Hz

1 24 Vdc +/-10%

**Alert and Alarm Switch Mechanism: 685B000X000**

0 Triac 5A, 245 Vac, 1000 Vac Isolation

1 Relay 10A, 245 Vac/30 Vdc, Form C (SPDT), 1000 Vac Isolation

**Enclosure: 685B0000XX0**

A1 Internal and Remote Reset

A2 External Pushbutton Reset

A3 Buffered Acceleration Signal though External BNC (100 mV/g)

A4 Same as A1 plus A2 and A3

**Interface: 685B000000X**

0 Dual Cord Grips: Wire Comp. Dia. 0.2 in to 0.35 in(5 to 9 mm)

1 Dual ½ in NPT Conduit Hubs

2 Single Cord Grip: Wire Comp. Dia. 0.39 in to 0.55 in(10 to 14 mm)

3 Single ½ in NPT Conduit Hub

4 Dual Opening, ½ in NPT Ports

5 Single Cord Grip (Left) / Single Conduit Hub (Right)

6 Single Conduit Hub (Left) / Single Cord Grip (Right)

**Mounting: 685B0000X00**

D Optional Model 080A209 Mounting Plate/Adapter

**NOTES:**

1) To obtain 60000 cpm (1000 Hz ) frequency response, grease must be applied to all mechanical couplings. Otherwise, frequency response is limited to approximately 30000 cpm (500 Hz.)

2) Factory Set.

3) Active only during calibration mode.

4) Reset can also be engaged via external connection to common.

5) Current will fluctuate at frequencies below 300 cpm (5 Hz)

6) See PCB Declaration of Conformance PS051 for details.

*All specifications are at room temperature unless otherwise specified.*



ICP® is a registered trademark of PCB Group, Inc.  
In the interest of constant product improvement, we reserve the right to change specifications without notice. Form DD030 Rev.F 2/23/99

|                 |                 |                 |                 |              |
|-----------------|-----------------|-----------------|-----------------|--------------|
| Drawn: NAD      | Engineer: NF    | Sales: JL       | Approved: NF    | Spec Number: |
| Date: 7/10/2023 | Date: 7/10/2023 | Date: 7/10/2023 | Date: 7/10/2023 | <b>34179</b> |



3425 Walden Avenue, Depew, NY 14043 800-959-4464 Fax (716) 684-3823 E-Mail: imisales@pcb.com



PCB Piezotronics Inc. claims proprietary rights in the information disclosed hereon. Neither it nor any reproduction thereof will be disclosed to others without the written consent of PCB Piezotronics Inc.

REVISIONS

| REV | DESCRIPTION          | ECN   | APP'D     |
|-----|----------------------|-------|-----------|
| NR  | RELEASED TO DRAFTING |       | ECB 3/07  |
| A   | REPLACE CONDUIT HUB  | 27505 | ECB 10/07 |

36971

CONDUIT HUB  
1/2-14 NPT

GROUND SCREW

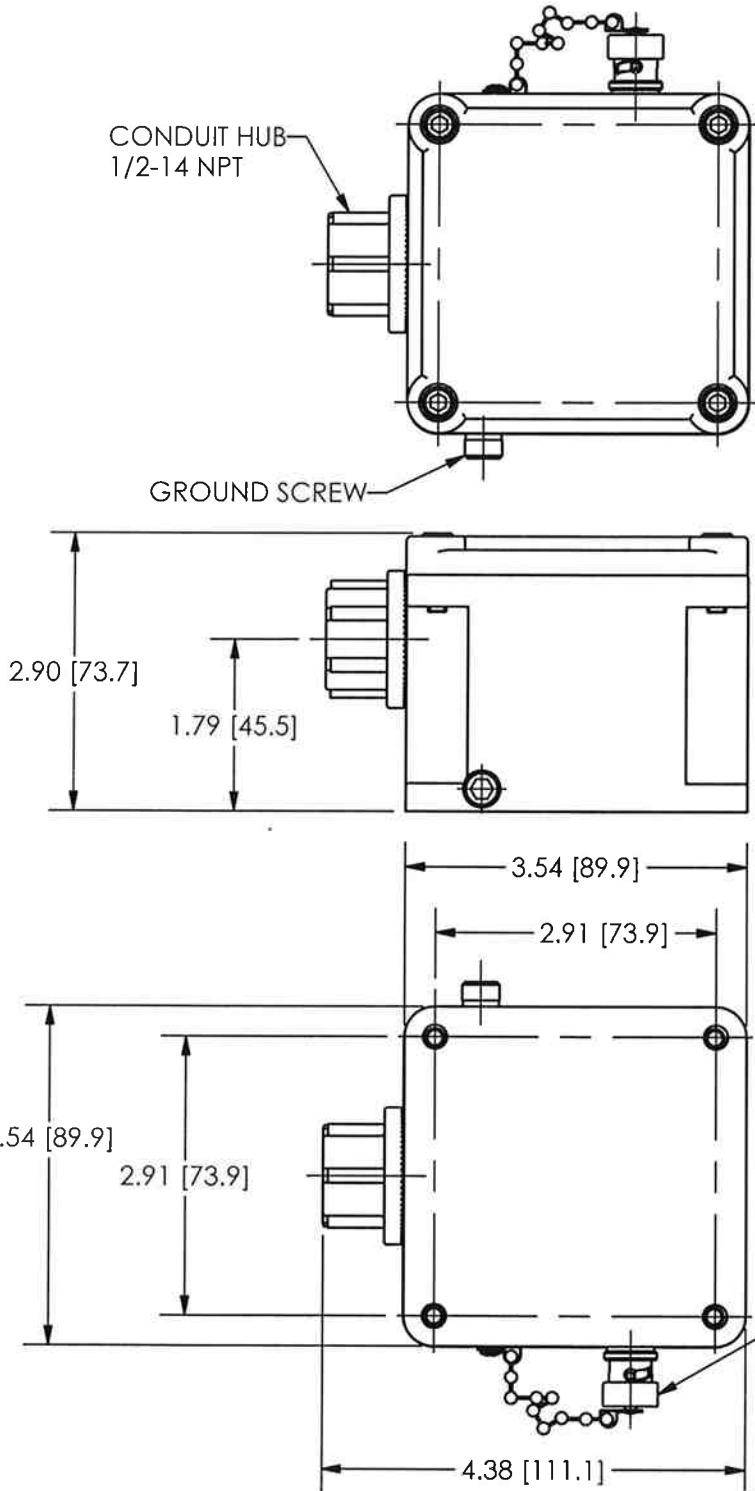

BNC JACK W/COVER  
FOR ANALOG VIBRATION  
SIGNAL OUTPUT

UNLESS OTHERWISE SPECIFIED TOLERANCES ARE:

| DIMENSIONS IN INCHES            | DIMENSIONS IN MILLIMETERS [IN BRACKETS] |
|---------------------------------|---|
| DECIMALS XX ± .03<br>XXX ± .010 | DECIMALS X ± 0.8<br>XX ± 0.25           |
| ANGLES ± 2 DEGREES              | ANGLES ± 2 DEGREES                      |
| FILLETS AND RADII .003 - .005   | FILLETS AND RADII [0.07 - 0.13]         |

|       |                     |       |     |          |
|-------|---------------------|-------|-----|----------|
| DRAWN | <i>mof</i> 10/16/07 | MFG   | JR  | 10/16/07 |
| CHK'D | ECB 10/16/07        | ENGR  | MJI | 10/16/07 |
| APP'D | NF 10/16/07         | SALES | JJ  | 10/16/07 |

TITLE  
**OUTLINE DRAWING**  
**MODEL 685BXXXXA33**  
**ELECTRONIC VIBRATION SWITCH**

**PCB PIEZOTRONICS™**  
 3425 WALDEN AVE. DEPEW, NY 14043  
 (716) 684-0001 E-MAIL: sales@pcb.com

|                       |                |
|-----------------------|----------------|
| CODE IDENT. NO. 52681 | DWG. NO. 36971 |
| SCALE: .5 X           | SHEET 1 OF 1   |