



Model 684A01/683A100003
Indicator / Alarm (for ICP® sensors)
Installation and Operating Manual

**For assistance with the operation of this product,
contact PCB Piezotronics, Inc.**

Toll-free: 800-959-4464
24-hour SensorLine: 716-684-0001
Fax: 716-684-3823
E-mail: imi@pcb.com
Web: www.imi-sensors.com





Service, Repair, and Return Policies and Instructions
--

The information contained in this document supersedes all similar information that may be found elsewhere in this manual.

Service – Due to the sophisticated nature of the sensors and associated instrumentation provided by PCB Piezotronics, user servicing or repair is not recommended and, if attempted, may void the factory warranty. Routine maintenance, such as the cleaning of electrical connectors, housings, and mounting surfaces with solutions and techniques that will not harm the physical material of construction, is acceptable. Caution should be observed to ensure that liquids are not permitted to migrate into devices that are not hermetically sealed. Such devices should only be wiped with a dampened cloth and never submerged or have liquids poured upon them.

Repair – In the event that equipment becomes damaged or ceases to operate, arrangements should be made to return the equipment to PCB Piezotronics for repair. User servicing or repair is not recommended and, if attempted, may void the factory warranty.

Calibration – Routine calibration of sensors and associated instrumentation is recommended as this helps build confidence in measurement accuracy and acquired data. Equipment calibration cycles are typically established by the users own quality regimen. When in doubt about a calibration cycle, a good “rule of thumb” is to recalibrate on an annual basis. It is

also good practice to recalibrate after exposure to any severe temperature extreme, shock, load, or other environmental influence, or prior to any critical test.

PCB Piezotronics maintains an ISO-9001 certified metrology laboratory and offers calibration services, which are accredited by A2LA to ISO/IEC 17025, with full traceability to SI through N.I.S.T. In addition to the normally supplied calibration, special testing is also available, such as: sensitivity at elevated or cryogenic temperatures, phase response, extended high or low frequency response, extended range, leak testing, hydrostatic pressure testing, and others. For information on standard recalibration services or special testing, contact your local PCB Piezotronics distributor, sales representative, or factory customer service representative.

Returning Equipment – *Following these procedures will ensure that your returned materials are handled in the most expedient manner.* Before returning any equipment to PCB Piezotronics, contact your local distributor, sales representative, or factory customer service representative to obtain a Return **Warranty, Service, Repair, and Return Policies and Instructions** Materials Authorization (RMA) Number. This RMA number should be clearly marked on the outside of all package(s) and on the packing

list(s) accompanying the shipment. A detailed account of the nature of the problem(s) being experienced with the equipment should also be included inside the package(s) containing any returned materials.

A Purchase Order, included with the returned materials, will expedite the turn-around of serviced equipment. It is recommended to include authorization on the Purchase Order for PCB to proceed with any repairs, as long as they do not exceed 50% of the replacement cost of the returned item(s). PCB will provide a price quotation or replacement recommendation for any item whose repair costs would exceed 50% of replacement cost, or any item that is not economically feasible to repair. For routine calibration services, the Purchase Order should include authorization to proceed and return at current pricing, which can be obtained from a factory customer service representative.

Contact Information – International customers should direct all inquiries to their local distributor or sales office. A

complete list of distributors and offices can be found at www.pcb.com. Customers within the United States may contact their local sales representative or a factory customer service representative. A complete list of sales representatives can be found at www.pcb.com. Toll-free telephone numbers for a factory customer service representative, in the division responsible for this product, can be found on the title page at the front of this manual. Our ship to address and general contact numbers are:

PCB Piezotronics, Inc.
3425 Walden Ave.
Depew, NY14043 USA
Toll-free: (800) 828-8840
24-hour SensorLineSM: (716) 684-0001
Website: www.pcb.com
E-mail: info@pcb.com



PCB工业监视和测量设备 - 中国RoHS2公布表
 PCB Industrial Monitoring and Measuring Equipment - China RoHS 2 Disclosure Table

部件名称	有害物质					
	铅 (Pb)	汞 (Hg)	镉 (Cd)	六价铬 (Cr(VI))	多溴联苯 (PBB)	多溴二苯醚 (PBDE)
住房	○	○	○	○	○	○
PCB板	X	○	○	○	○	○
电气连接器	○	○	○	○	○	○
压电晶体	X	○	○	○	○	○
环氧	○	○	○	○	○	○
铁氟龙	○	○	○	○	○	○
电子	○	○	○	○	○	○
厚膜基板	○	○	X	○	○	○
电线	○	○	○	○	○	○
电缆	X	○	○	○	○	○
塑料	○	○	○	○	○	○
焊接	X	○	○	○	○	○
铜合金/黄铜	X	○	○	○	○	○
本表格依据 SJ/T 11364 的规定编制。						
○：表示该有害物质在该部件所有均质材料中的含量均在 GB/T 26572 规定的限量要求以下。						
X：表示该有害物质至少在该部件的某一均质材料中的含量超出 GB/T 26572 规定的限量要求。						
铅是欧洲RoHS指令2011/65/ EU附件三和附件四目前由于允许的豁免。						

CHINA RoHS COMPLIANCE

Component Name	Hazardous Substances					
	Lead (Pb)	Mercury (Hg)	Cadmium (Cd)	Chromium VI Compounds (Cr(VI))	Polybrominated Biphenyls (PBB)	Polybrominated Diphenyl Ethers (PBDE)
Housing	O	O	O	O	O	O
PCB Board	X	O	O	O	O	O
Electrical Connectors	O	O	O	O	O	O
Piezoelectric Crystals	X	O	O	O	O	O
Epoxy	O	O	O	O	O	O
Teflon	O	O	O	O	O	O
Electronics	O	O	O	O	O	O
Thick Film Substrate	O	O	X	O	O	O
Wires	O	O	O	O	O	O
Cables	X	O	O	O	O	O
Plastic	O	O	O	O	O	O
Solder	X	O	O	O	O	O
Copper Alloy/Brass	X	O	O	O	O	O

This table is prepared in accordance with the provisions of SJ/T 11364.

O: Indicates that said hazardous substance contained in all of the homogeneous materials for this part is below the limit requirement of GB/T 26572.

X: Indicates that said hazardous substance contained in at least one of the homogeneous materials for this part is above the limit requirement of GB/T 26572.

Lead is present due to allowed exemption in Annex III or Annex IV of the European RoHS Directive 2011/65/EU.

DOCUMENT NUMBER: 21354

DOCUMENT REVISION: **D**

ECN: 46162

Models 684A0/684A3 Panel Meter Enclosures



Operating Guide with Enclosed Warranty Information

3425 Walden Avenue, Depew, New York 14043-2495

Phone (716) 684-0003

Fax (716) 684-3823

Toll Free Line 1-800-959-4IMI

MANUAL NUMBER: 19406
MANUAL REVISION: NR

Table of Contents

<i>Introduction.....</i>	<i>Page 3</i>
<i>General Features.....</i>	<i>Page 3</i>
<i>Specifications.....</i>	<i>Page 3</i>
<i>Installation and Wiring.....</i>	<i>Page 4</i>
<i>Figure 1 -- Terminal Block Diagram.....</i>	<i>Page 5</i>
<i>Figure 2 – Dimension Drawing.....</i>	<i>Page 6</i>
<i>ESD Warning.....</i>	<i>Page 7</i>
<i>Ordering Information.....</i>	<i>Page 8</i>

Warranty/Service

<i>Warranty, Service & Return Procedure.....</i>	<i>Page 9</i>
<i>Customer Service.....</i>	<i>Page 10</i>

Introduction

Models 684A0 and 684A3 Enclosures are designed to accept IMI Sensor's 683A Series Panel Meter/Controllers. Internal screw type terminal blocks are incorporated for easy interface between the Sensor, Panel Meter, and Process Equipment. Models 684A0 and 684A3 utilize NEMA 4X (IP66) enclosures.

General Features

- Enclosure has been machined to readily accept IMI Sensor's model 683A Series Panel Meters/Controllers.
- Easy installation of Enclosure with supplied mounting accessory kit.
- Screw terminal blocks provide for fast and reliable installation of wiring.
- Different Panel Meters/Controllers can be mixed within one Enclosure.
- Panel Meter/Controller comes factory installed and wired to its respective terminal blocks.
- Enclosure is rated NEMA 4X (IP66)

Specifications

- **Channels:** 1 to 3 (User defined)
- **Terminal Strip Connectors:** Input, Output, Power, Raw Vibration, SP1, SP2, and Retransmit.
- **BNC Jacks:** Raw Vibration
- **Terminal Strips:** 0.315" (8mm) Two Screw
- **Wire Size:** 12 to 24 AWG (3.31 to 0.511 mm²)
- **Cord Grips:** 1-PGME13, 5 to 15 PGM07 (depending on number of channels)
- **Enclosure Type:** NEMA4X (IP66)
- **Dimensions (HxWxD):** 10x8x6 in. (254x203x152mm)
- **Dimensions (HxWxD) w/Meter, Grips, BNC:** 11.5x9x6.7 in. (292x229x170mm)
- **Weight:** 4.2lbs (1.9kg)
- **Weight w/Meter, Grips, BNC:** 4.9lbs (2.2kg)
- **Panel Cutout (HxW):** 1.715x3.615 in. (43.6x91.8mm)
- **BNC Cutout:** 0.375 in. Dia. (9.5mm Dia.)

Installation and Wiring

The 684A0/684A3 Enclosure is designed for use in conjunction with the Series 683A Panel Meter/Controller. The Enclosure can be located near the machine that needs monitoring. Depending on the Enclosure's configuration, up to 3 sensors can be connected to the internal terminal blocks for interface to the Panel Meters/Controllers. The terminal blocks also provide for output connections including Raw Vibration, 4-20mA Retransmit, and Alarm/Alert Relays.

Establish an easily accessible location for installation and keep in mind where the cabling will be oriented. Once the unit has been mounted, begin making appropriate connections for the interface cables.

All user connections are made to the terminal blocks (Fig.1) attached to the inside rear panels of the unit through cord grips located on the bottom of the enclosure. The largest cord grip on the Enclosure should be used for power connection, all other cord grips are used for sensor and signal interface.

Observe the labels on the terminal blocks when making connections. These labels identify the Panel Meter/Controller interface where #1 is the TOP METER, #2 is the MIDDLE METER, and #3 is the BOTTOM METER. Each Sensor Input has three connections, which are made on the terminal strip; one for the signal/power (typically red wire, +), another for ground (typically black wire), and the third is for the shield (typically a drain wire, SHIELD GND).

Panel Meter/Controller Power is connected to the respective terminal block located in the lower left corner. Line, Neutral, and Earth Ground are connected to this block. Earth Ground should also be connected to the spade lugs located on the two bottom screws that hold the terminal block mounting brackets.

The output connections from the terminal blocks consist of Raw Vibration, 4-20mA Retransmit, Alert (typically SP1) and Alarm (typically SP2) Relays. All of these connections should go to process control/monitoring equipment, additional signal conditioners, and machine diagnostic tools.

To install the wires, unscrew the terminal block so that enough room exists to insert a wire stripped of its insulation. Insure that no bare wire is exposed and tighten the screw on the terminal block to hold the wire in place.

To install Earth Ground to the spade lugs, remove the lugs by first unscrewing the terminal block mounting bracket. Insert the Earth Ground wire into the lug and crimp using a crimping tool or a set of pliers. Reinstall the lug to its original location. Note that all terminal block mounting bracket screws do not need to be removed during Earth Ground installation. It is recommended that only the screws holding the lugs to the bracket be removed.

Regardless of ordered options, all Enclosures come equipped to electrically accommodate three meters. Therefore, some terminal blocks may be unused.

Terminal Block Diagram

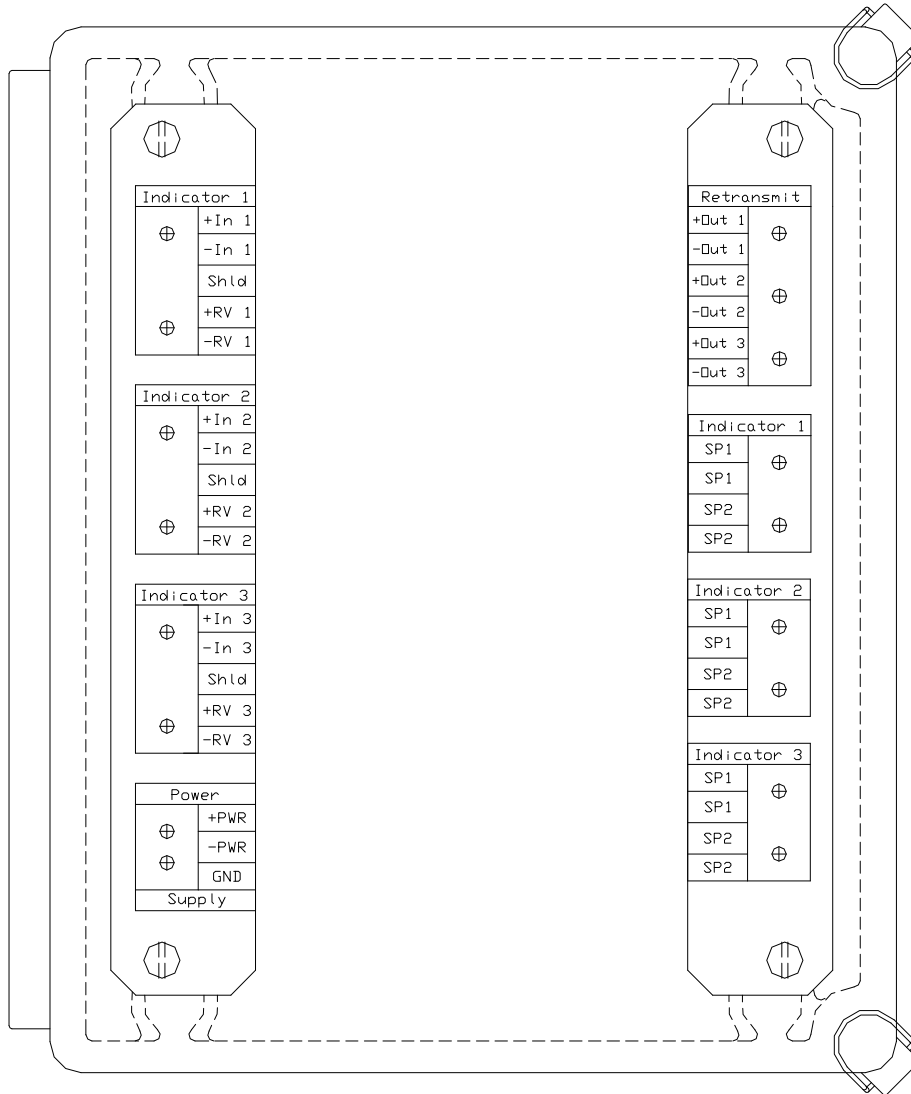

Figure 1

Dimension Drawing

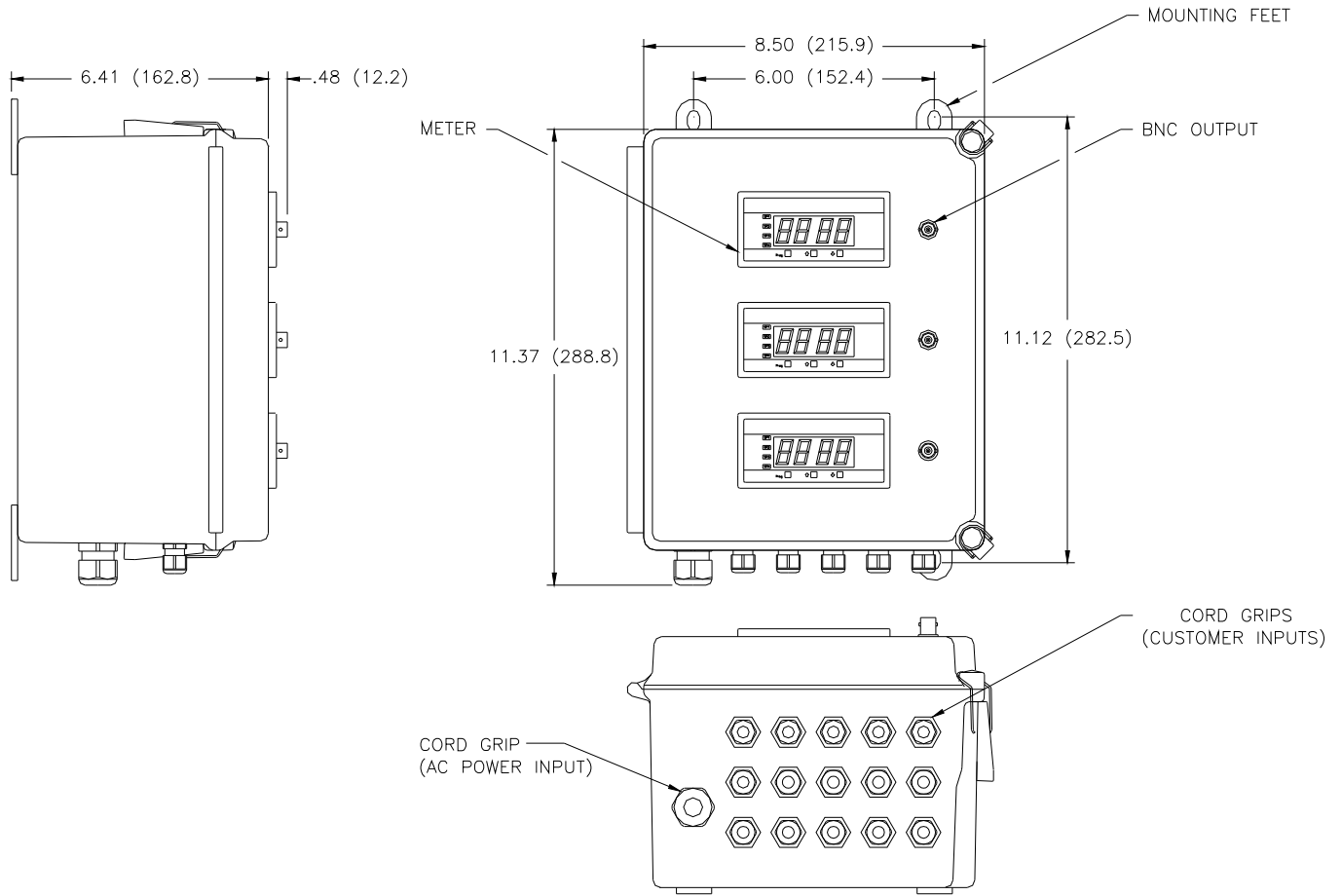

Figure 2

Model 684A03 Shown

Warning 1 – ESD sensitivity

The power supply/signal conditioner should not be opened by anyone other than qualified service personnel. This product is intended for use by qualified personnel who recognize shock hazards and are familiar with the safety precautions required to avoid injury.

Warning 2 – ESD sensitivity

This equipment is designed with user safety in mind; however, the protection provided by the equipment may be impaired if the equipment is used in a manner not specified by PCB Piezotronics, Inc.

Caution 1 – ESD sensitivity

Cables can kill your equipment. High voltage electrostatic discharge (ESD) can damage electrical devices. Similar to a capacitor, a cable can hold a charge caused by triboelectric transfer, such as that which occurs in the following:

- *Laying on and moving across a rug,*
- *Any movement through air,*
- *The action of rolling out a cable, and/or*
- *Contact with a non-grounded person.*

The PCB solution for product safety:

- *Connect the cables only with the AC power off.*
- *Temporarily “short” the end of the cable before attaching it to any signal input or output.*

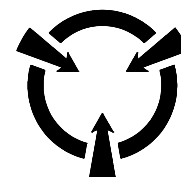

CAUTION
ELECTROSTATIC
DISCHARGE SENSITIVE

Caution 2 – ESD sensitivity

ESD considerations should be made prior to performing any internal adjustments on the equipment. Any piece of electronic equipment is vulnerable to ESD when opened for adjustments. Internal adjustments should therefore be done ONLY at an ESD-safe work area. Many products have ESD protection, but the level of protection may be exceeded by extremely high voltage.

Ordering Information

IMI Part Number: **684A 0 1**

Basic Model Number

684A

Enclosure Type

- 0 6x8x10 in. with BNC Holes
- 3 6x8x10 in. without BNC Holes

Number of Channels

- 1 One Panel Meter Cutout
- 2 Two Panel Meter Cutouts
- 3 Three Panel Meter Cutouts

Notes:

- 1) When only 1 meter is ordered, 6 cord grips are installed (1 Power, 5 Signal). Blanks will occupy 10 holes.
- 2) When 2 meters are ordered, 11 cord grips are installed (1 Power, 10 Signal). Blanks will occupy 5 holes.
- 3) When a Model 683A0XXXXX Series Panel Meter is installed into a Model 684A0X Enclosure the BNC hole will be populated with a Blank.
- 4) When a Model 683A1XXXXX Series Panel Meter is installed into a Model 684A0X Enclosure the BNC hole will be populated with an off-ground BNC Jack.
- 5) All Enclosures come equipped with the correct number of terminal blocks and cord grip holes to accommodate 3 Meters.

Example:

Part Number: 684A02

6x8x10 Enclosure with 2 Meter/Controller cutouts and 2 BNC holes. One cord grip installed for Power cabling and 10 cord grips installed for Signal cabling. Five remaining cord grip holes are occupied by blanks

Warranty

IMI instrumentation is warranted against defective material and workmanship for 1 year unless otherwise expressly specified. Damage to instruments caused by incorrect power or misapplication, is not covered by warranty. *If there are any questions regarding power, intended application, or general usage, please consult with your local sales contact or distributor.* Batteries and other expendable hardware items are not covered by warranty.

Service

Because of the sophisticated nature of IMI instrumentation, field repair is typically **NOT** recommended and may void any warranty. If factory service is required, return the instrumentation according to the "Return Procedure" stated below. *A repair and/or replacement quotation will be provided prior to servicing at no charge.* Before returning the unit, please consult a factory IMI applications engineer concerning the situation as certain problems can often be corrected with simple on-site procedures.

Return procedure

To expedite returned instrumentation, contact a factory IMI applications engineer for a RETURN MATERIAL AUTHORIZATION (RMA) NUMBER. Please have information available such as model and serial number. Also, to insure efficient service, *provide a written description of the symptoms and problems with the equipment to a local sales representative or distributor, or contact IMI if none are located in your area.*

Customers outside the U.S. should consult their local IMI distributor for information on returning equipment. For exceptions, please contact the International Sales department at IMI to request shipping instructions and an RMA. For assistance, please call (716) 684-0003, or fax us at (716) 684-3823. You may also receive assistance via e-mail at imi@pcb.com or visit our web site at www.pcb.com.



Customer Service

IMI, a division of PCB Piezotronics, guarantees **Total Customer Satisfaction**. If, at any time, for any reason, you are not completely satisfied with any IMI product, IMI will repair, replace, or exchange it at no charge. You may also choose, within the warranty period, to have your purchase price refunded.

IMI offers to all customers, at no charge, 24-hour phone support. This service makes product or application support available to our customers, day or night, seven days a week. When unforeseen problems or emergency situations arise, call the **IMI Hot Line at (716) 684-0003**, and an application specialist will assist you.



3425 Walden Avenue, Depew, NY 14043-2495
Phone: (716) 684-0003 • USA Fax: (716) 684-3823 • INTL Fax: (716) 684-4703

*ICP® is a registered trademark of PCB Group, Incorporated,
which uniquely identifies PCB sensors that incorporate built-in microelectronics.*



Model 683A1 ICP[®] Process Indicator/Controller



Operating Guide with Enclosed Warranty Information

3425 Walden Avenue, Depew, New York 14043-2495

Phone (716) 684-0003

Fax (716) 684-3823

Toll Free Line 1-800-959-4IMI

**MANUAL NUMBER: 19163
MANUAL REVISION: C
ECN NUMBER: 18874**



Table of Contents

Introduction.....	Page 3
General Features, Software Features	
Specifications.....	Page 4
Controls and Indicators.....	Page 5
Glossary of Programming Symbols.....	Page 6
Software Logic Tree.....	Page 7
Programming the 683A1.....	Page 8
Wiring and Installation.....	Page 13
Configuring the 683A1	Page 17
Accessories.....	Page 18
ESD Sensitivity.....	Page 20
Ordering Information.....	Page 21

Warranty/Service

Warranty, Service & Return Procedure.....	Page 22
Customer Service	Page 23

Introduction

The Model 683A1 ICP[®] Process Indicator/Controller is an intelligent 4-digit modular panel meter with software features for monitoring, measurement, and control applications complete with 0.56" LED in a 1/8 DIN 96x48 case. The 683A1 operates from a single power supply and will supply 24Vdc/4mA excitation for sensor power. The indicator/controller comes equipped with two 5 Amp Form A relays with independent setpoints and time delay.

General Features

- External transmitters, signal conditioners, or power supplies can be eliminated by direct connection of the sensor to the indicator/controller.
- Optional isolated 16-bit analog output. User or factory scalable to 4 to 20 mA across any desired digital span from \pm one count to the full-scale range of – 1999 to 9999 (12000 counts).
- 24Vdc/4mA excitation to power sensor.
- Standard Internal DIP switch selectable vibration ranges include:

Acceleration (g's)	Velocity (in/sec)	Displacement (mils p-p)
5.000	0.500	25.0
10.00	1.000	50.0
20.00	2.000	100.0

- Two 5 Amp Form A relays, additionally two 5 Amp Form A or 10 Amp Form C relays are available.
- Programmable Time Delay to 9999 seconds.
- Internal DIP switch selection for Peak or RMS display.
- User specified, factory installed, High and Low pass 2-pole filtering.
- Analog output signal connection (RV) for conducting frequency analysis and machinery diagnostics.

Software Features

Three-button front panel programming of:

- Scale Factor and Offset
- Decimal point setting.
- Four-level brightness control of digital display.
- Peak and valley view and reset.
- Four programmable setpoints.
- Adjustable delay-on-make and delay-on-break time for setpoints 1 and 2.
- Relay activation can be selected to occur above (HI) or below (LO) each setpoint.

Specifications

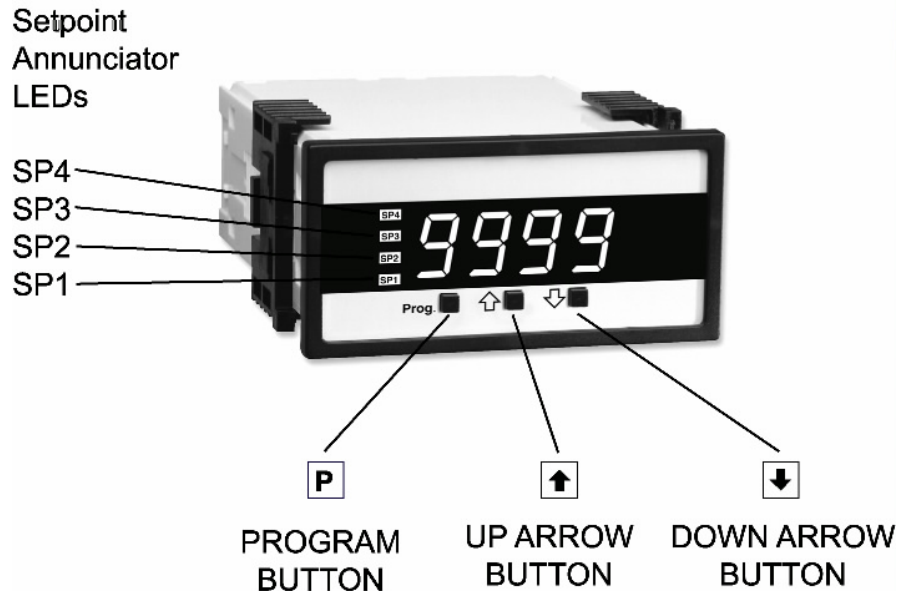

- **Input Specs:** 100mV/g
- **ICP[®] Sensor Excitation:** 24Vdc/4mA, ±1Vdc/±1mA
- **A/D Converter:** 14 bit single slope
- **Accuracy:** ±2.0% of Scale Factor + 2 counts
- **Frequency Response:** 3Hz to 10Khz (Standard)
Acceleration: -3dB at 3Hz ±0.5Hz, -3dB at 10kHz ±0.5kHz
Velocity: -3dB at 3.5Hz ±0.5Hz, -3dB at 10kHz ±0.5kHz
Displacement: -3dB at 3.5Hz ±0.5Hz, 1000Hz max.
- **Temp. Coeff.:** 100 ppm/°C (Typical)
- **Warm up time:** 2 minutes
- **Conversion Rate:** 5 conversions per second (Typical)
- **Display:** 4 digit 0.56" Red LED display, Range –1999 to 9999 counts.
- **Polarity:** Assumed positive. Displays – negative
- **Decimal Selection:** Front panel button selectable, X•X•X•X•
- **Positive Overrange:** Top segments of digital display flash
- **Negative Overrange:** Bottom segment of digital display flash
- **Relay Output:** Two 5 A Form A (SPST) relays 230VAC/30VDC standard.
Additionally two 5 Amp Form A (SPST) or 10 Amp Form C (SPDT) relays.
- **Optional Analog Output:** Isolated 16 bit user scalable 4-20mA retransmit @ 0 to 500 ohms max loop resistance.
- **Power Supply:** Auto sensing wide range supply 85-265 VAC / 95-370 VDC @ 2.5W max 3.5W
- **Operating Temp.:** 0 to 60 °C
- **Storage Temp:** –20 °C to 70 °C.
- **Relative Humidity:** <95% (non condensing)
- **Case Dimensions:** 1/8 DIN, Bezel: 96x48 mm (3.78"x1.89")
Depth behind bezel 117 mm (4.61")
Plus 11.8 mm (0.47") for Right-angled connectors, or plus 20 mm (0.79") for Straight-thru connectors.
- **Weight:** 6.5 oz., 8.5 oz when packed

Controls and Indicators





Front Panel Buttons

- **Program Button**

The  button is used to move from one program step to the next. When pressed at the same time as the  button, it initiates the **calibration mode**. When pressed at the same time as the  button, it initiates the **setpoint setting mode**.

- **Up Button**

When in the operational display, pressing the  button alone, allows you to view and reset the Peak and Valley (Highest and Lowest Readings.)

When in **calibration mode** or the **setpoint setting mode** the  button is used to increase the value of the displayed parameter.













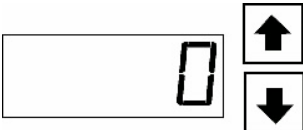

- **Down Button**

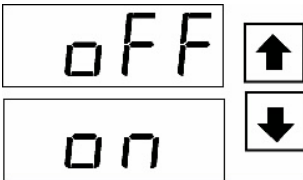

When in the operational display, pressing the  button alone allows you to view, but not change, the setting of setpoint 1,2,3,& 4.

When in **calibration mode** or the **setpoint setting mode** the  button is used to decrease the value of the displayed parameter.

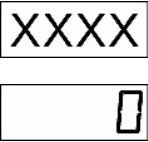
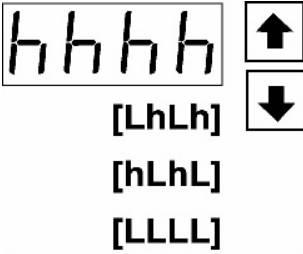
Glossary of Programming Symbols

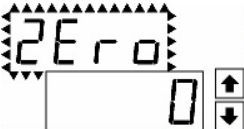
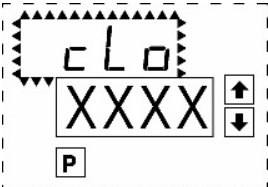
To explain software-programming procedures, logic diagrams are used to visually assist in following the programming steps. The following symbols are used to represent various functions and associated display elements of the 683A1:

Symbol	Explanation	Symbol	Explanation
	This symbol represents the OPERATIONAL DISPLAY.	[ScALE] [9999]	Text or numbers shown between square brackets in a procedure indicate the programming code name of the function or the value displayed on the meter display.
	When a button is shown, press and release it to go onto the next step in the direction indicated by the arrow. When two or more buttons are shown, each with an arrow, this indicates there are a number of programming choices.		When the  and  buttons are shown together, the display value can be increased by pressing and releasing the  button or decreased by pressing and releasing the  button.
	When two buttons are shown side by side and enclosed by a dotted line, they must be pressed at the same time then released to go onto the next programming step.		When the  and  buttons are shown with two displays, either display can be selected by pressing and releasing the  or  buttons.
	If the display is shown with XXXX it means the value displayed will be the previously set value. When a number is shown it indicates the initial factory default setting or a specific "example number."		When there are more than two display selections they are shown in brackets below the first display and are also selectable by pressing and releasing the  or  buttons.
	When two displays are shown together with bursts, this indicates that the display is toggling (flashing) between the name of the function and the value.		A dotted box indicates these functions are omitted or bypassed when the related hardware is not present.

 is the PROGRAM button,  is the UP button,  is the DOWN button.

Software Logic Tree

The 683A1 is an intelligent meter with a hierarchical software structure designed for easy programming and operation, as shown below in the software logic tree. After the meter has been powered up, the four digits light up for three seconds and then settle to the operational display indicating the input signal.

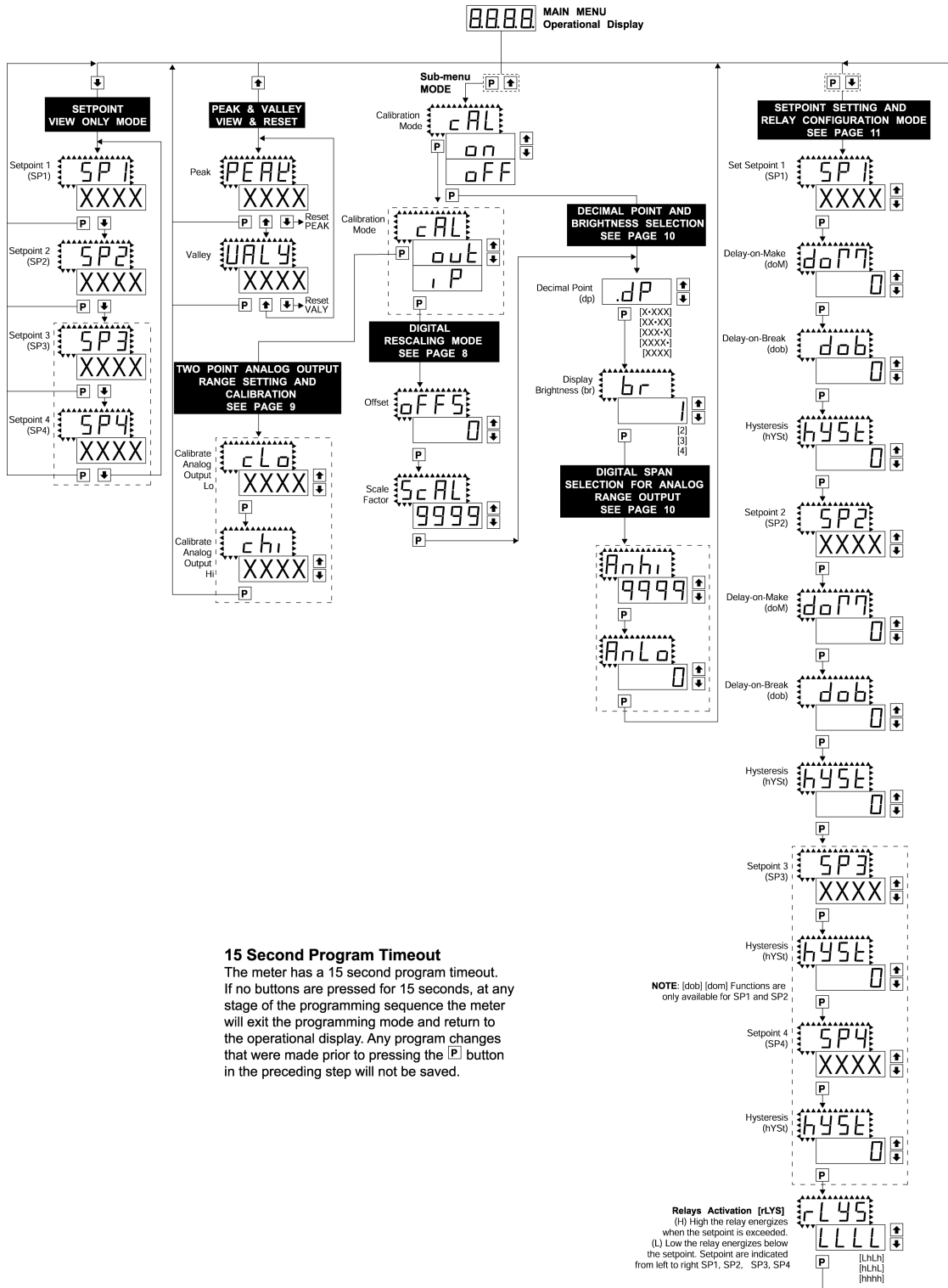

15 Second Program Timeout
 The meter has a 15 second program timeout. If no buttons are pressed for 15 seconds, at any stage of the programming sequence the meter will exit the programming mode and return to the operational display. Any program changes that were made prior to pressing the [P] button in the preceding step will not be saved.

Programming the 683A1

Digital Scaling

The 683A1 meter may be rescaled without applying an external signal by changing the Offset and Scale factor.

Offset is the reading that the meter will display for a 0mV input. The Offset may be set to any value from -1999 to +9999. The default value of the Offset is 0000.

Scale Factor is the gain of the meter. The displayed reading is directly proportional to the Scale Factor. The default value of the Scale Factor is 1000 for a 1ips accelerometer, but it may be set to any value between -1999 and +9999.

For an input of 2.000V a calibrated meter will read 1000 with the default Scale Factor of 1000, 2000 with a Scale Factor of 2000, and 500 with a Scale Factor of 500.

Digital Scaling Procedure

STEP A Enter the Calibration Mode

- 1) Press the **P** and the **↑** buttons at the same time. Display toggles between [cAL] and [oFF].
- 2) Press the **↑** or **↓** button. Display changes from [oFF] to [on].
- 3) Press the **P** button. Display toggles between [cAL] and [out].

STEP B Select Between Calibration of Input or Output

Note: If the analog output option is not present, Step B is skipped and the program goes directly from Step A to Step C.

- 1) Press the **↑** or **↓** button to select the display toggling from [cAL] to [iP].
- 2) Press the **P** button. Display toggles between [oFFS] and the previous offset setting.

STEP C Set the Offset on the Digital Display

- 1) Using the **↑** and **↓** buttons, adjust the digital display to the desired offset. This is the reading the meter will display for a 0mV input.
- 2) Press the **P** button. Display toggles between [SCAL] and the previous scale factor.

STEP D Set the Scale factor on the Digital Display

- 1) Using the **↑** and **↓** buttons, adjust the meter display to the desired Scale Factor. The default value is 1000, for which a 2.000V input will read 1000. If the Scale factor is changed the display will change proportionally. Therefore if the Scale Factor is changed to 2000 then for the same 2.000V input the display will read 2000.
- 2) Press the **P** button.

The Digital Calibration Procedure Mode is Now Complete.

The menu branches to the DECIMAL POINT AND BRIGHTNESS SELECTION, (see page 10) and the display flashes [dP] and the previous decimal point selection.

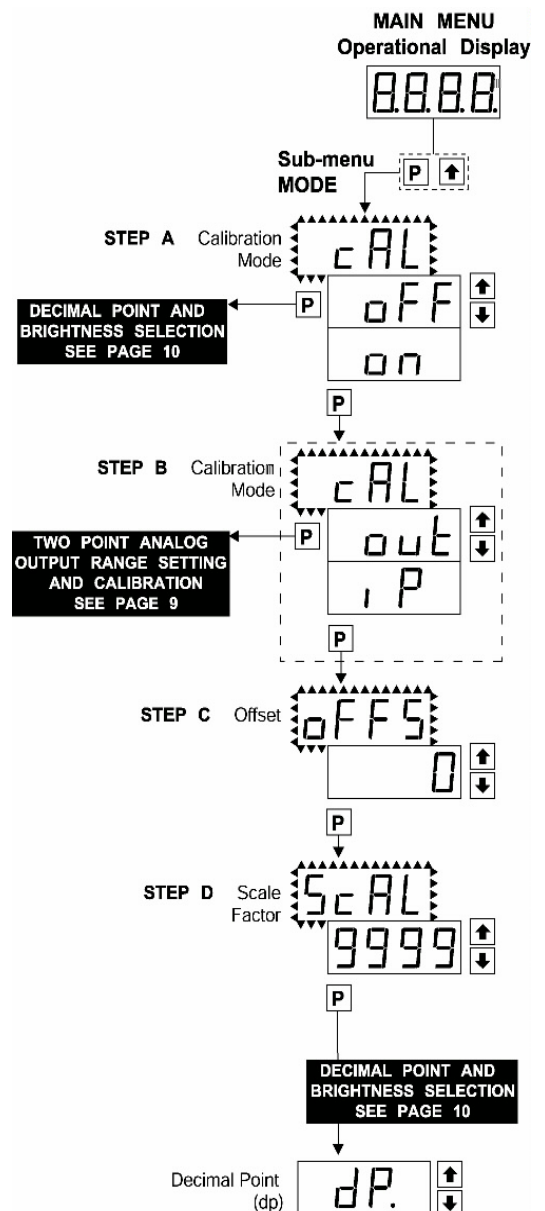

Two Point Analog Output Range Setting and Calibration

STEP A Enter the Calibration Mode

- 1) Press the **P** and the **↑** buttons at the same time. Display toggles between [cAL] and [oFF].
- 2) Press the **↑** or **↓** button. Display changes from [oFF] to [on].
- 1) Press the **P** button. Display toggles between [cAL] and [out].

Note: If at this point the display skips directly to toggle between [oFFS] and the previous [oFFS] setting, the software is detecting that the optional analog output hardware is NOT installed.

STEP B Enter the Analog [oUT] Output Mode

- 1) Press the **P** button. Display toggles between [cLo] and internal scale factor.

STEP C Set or Calibrate the [cLo] Low Analog Output Range

- 1) Connect a multimeter to pins 16 and 17 on the output module. See Rear Panel Pinouts on Page 8). Using the **↑** and **↓** buttons, adjust the analog output to the desired low value as shown on the multimeter display. cLo may be adjusted to any value from -0.3mA to 17mA. (Factory Default is 4mA)
- 2) Press the **P** button. Display toggles between [cHi] and internal scale factor.

STEP D Set or Calibrate the [cHi] Analog Output Range

- 1) Using the **↑** and **↓** buttons, adjust the analog output to the desired high value as shown on the multimeter display. cHi may be adjusted to any value from 17mA to 21mA. (Factory Default is 20mA)
- 2) Press the **P** button. The display exits the calibration mode and returns to the operational display.

Note: Having established the Low and High range of the analog output, the digital span can now be selected which will set the two digital points between which the analog output will occur. (See Digital Span selection next page).

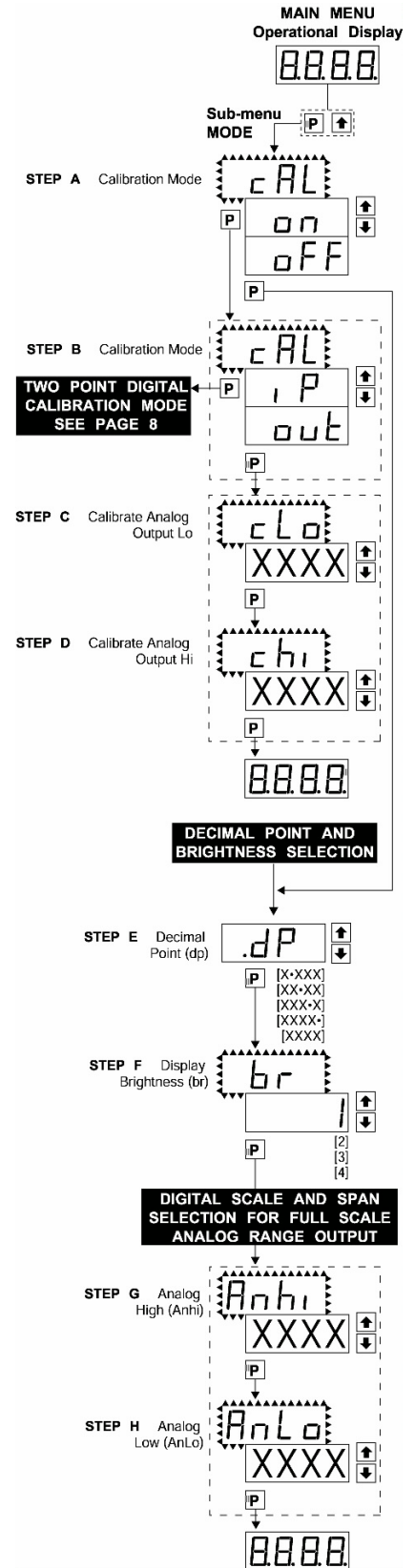

Decimal Point and Brightness Selection

STEP A Enter the Decimal Point and Brightness Mode Through the Sub Menu [CAL]{oFF}

- 2) Press the **P** and the **↑** buttons at the same time. Display toggles between [cAL] and [oFF].
- 3) Press the **P** button. Display shows the previous [dp] selection.

STEP E Set the Decimal Point

- 1) Using the **↑** and **↓** buttons, adjust the display to the desired decimal point setting. (Factory Default is X.XXX)
- 2) Press the **P** button. Display toggles between [Br] and the previous [Br] setting.

STEP F Set the Display Brightness

- 1) Using the **↑** and **↓** buttons, adjust the display to the desired brightness setting (4 is the brightest setting).
- 2) Press the **P** button. Display brightness changes to new setting and display toggles between [Anhi] and the previous [Anhi] setting.

Digital Span Selection for Analog Range Output

STEP G Setting the Digital Span Point for Analog High Output

- 1) Using the **↑** and **↓** buttons, adjust the display to the desired digital value which sets the point at which the selected analog high output range will occur. (Factory Default is 1000)
- 2) Press the **P** button. Display toggles between [AnLo] and the previous [AnLo] setting.

STEP H Setting the Digital Span Point for Analog Low Output

- 1) Using the **↑** and **↓** buttons, adjust the display to the desired digital value which sets the point at which the selected analog low output range will occur. (Factory Default is 0)
- 2) Press the **P** button. The display exits the calibration mode and returns to the operational display.

Note: Any two digital scale points from -1999 to 9999 can be selected. The digital scale points for analog high and analog low can be reversed for a 20mA to 4mA output. The span of the digital scale can be as small as two counts however small spans cause the 16 bit D to A to increment in stair case steps.

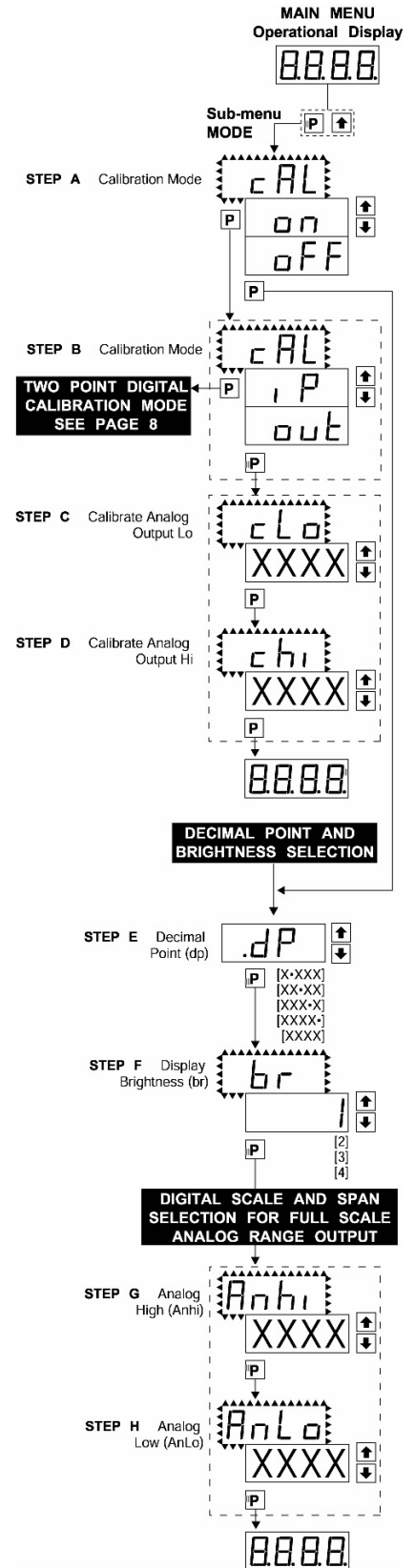

Setpoint Setting and Relay Configuration Mode

The following programming steps are required to enter the setpoint values and configure the relay functions in a meter with four relays using four setpoints. Generally if less than four relays are installed the software auto detects the missing relays and deletes reference to them from the menu. In some cases setpoints without relays are operational for display purposes only.

STEP A Enter the Setpoint Mode

- 1) Press the **P** and **↓** buttons at the same time. Display toggles between [SP1] and the previous [SP1] setting.

STEP B Setpoint1 (SP1)

- 1) Using the **↑** and **↓** buttons, adjust the display to the desired SP1 value.
- 2) Press the **P** button. Display toggles between [doM] and the previous [doM] setting.

STEP C Set the SP1 Delay-on-Make (doM) Delay Time Setting

- 1) Using the **↑** and **↓** buttons, adjust the display to the desired [doM] value (0 to 9999 seconds). The reading must continuously remain in an alarm condition until this delay time has elapsed before the relay will make contact (energize).
- 2) Press the **P** button. Display toggles between [dob] and the previous [dob] setting.

STEP D Set the SP1 Delay-on-Break (dob) Delay Time Setting

- 1) Using the **↑** and **↓** buttons, adjust the display to the desired [dob] value (0-9999 seconds). The reading must continuously remain in a non-alarm condition until this delay time has elapsed before the relay will break contact (de-energize).
- 2) Press the **P** button. Display toggles between [hYST] and the previous [hYST] setting.

STEP C Set the Hysteresis Setting for Setpoint 1

- 1) Using the **↑** and **↓** buttons, adjust the display to the desired hysteresis [hYST] value.
- 2) Press the **P** button. Display toggles between [SP2] and the previous [SP2] setting.

Note: Steps, F, G, H, and J have functionally the same procedure as steps B, C, D, and E shown above.

STEP F Set Setpoint 2 (SP2)

STEP G Set the SP2 Delay-on-Make (doM) Delay Time Setting

STEP H Set the SP2 Delay-on-Break (dob) Delay Time Setting



STEP I Set the Hysteresis Setting for Setpoint 2

- 1) Using the **↑** and **↓** buttons, adjust the display to the desired hysteresis [hYST] value.
- 2) Press the **P** button. Display toggles between [SP3] and the previous [SP3] setting.

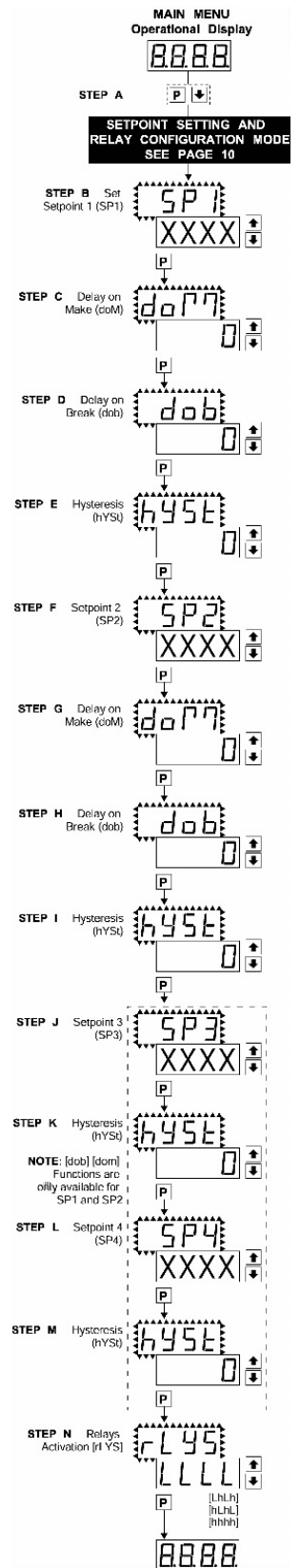

SETPOINT 3, 4, AND RELAY ACTIVATION MODE CONTINUED NEXT PAGE.





STEP J Set Setpoint 3 (SP3) (No [doM] or [dob])

- 1) Using the  and  buttons, adjust the display to the desired SP3 value.
- 2) Press the  button. Display toggles between [hYST] and the previous [hYST] setting.



STEP K Set the Hysteresis Setting for Setpoint 3

- 1) Using the  and  buttons, adjust the display to the desired hysteresis [hYST] value.
- 2) Press the  button. Display toggles between [SP4] and the previous [SP4] setting.

STEP L Set Setpoint 4 (SP4) (No [doM] or [dob])



- 1) Using the  and  buttons, adjust the display to the desired SP4 value.
- 2) Press the  button. Display toggles between [hYST] and 0.

STEP M Set the Hysteresis Setting for Setpoint 4

- 1) Using the  and  buttons, adjust the display to the desired hysteresis [hYST] value.
- 2) Press the  button. Display toggles between [rLYS] and the previous relay setting.

STEP N Set Relay Activation mode [rLYS]

(h) High the relay energizes when the setpoint is exceeded. (L) Low the relay energizes below the setpoint. The setpoint is indicated from left to right SP1, SP2, SP3, SP4.

- 1) Using the  and  buttons, adjust the reading on the display to the desired relay settings: [LLLL], [LhLh], [hLhL], [hhhh].
If only 2 relays installed [Lh--], [hL--], [hh--], [LL--].
- 2) Press the  button. The meter exits the setpoint mode and returns to the operational display.

The Setpoint Relay programming mode is now complete.

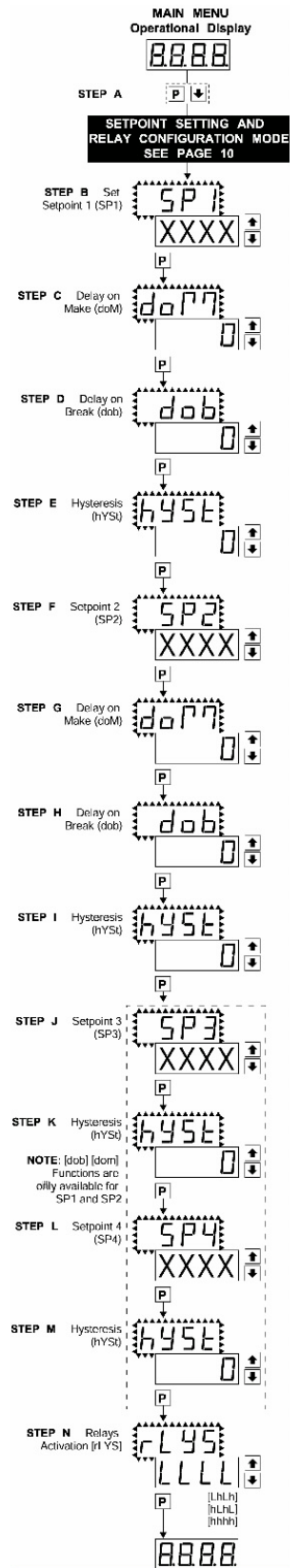

Wiring and Installation

Pinout Diagram

The Rear View Meter diagram shows the meter with the relay configuration: dual 10 Amp Form C and dual 5 Amp Form A relays. An analog output module is also shown as installed.

The 683A1 uses plug-in type screw terminal connectors for all input and output connections. The power supply connections (pins 14 and 15) have a unique plug and socket outline to prevent cross connection. The main board and input signal conditioner use right-angled connectors as standard. The output module uses straight-thru connectors as standard.

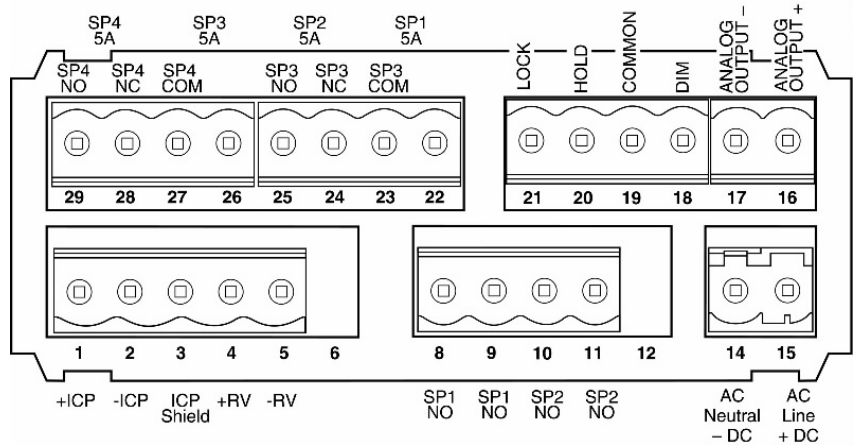

Connectors

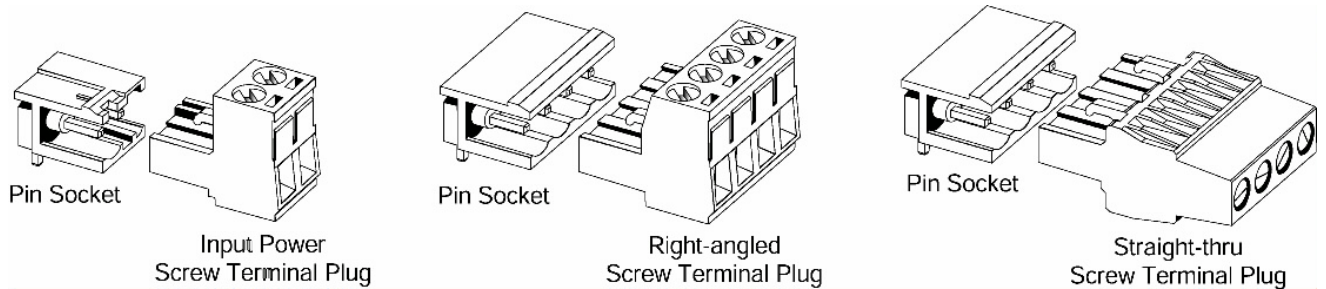

WARNING

AC and DC input signals and power supply voltages can be hazardous. DO NOT connect live wires to screw terminal plugs, and DO NOT insert, remove, or handle screw terminal plugs with live wires connected.

Typical Wiring Diagram (CE Power Supply Option)

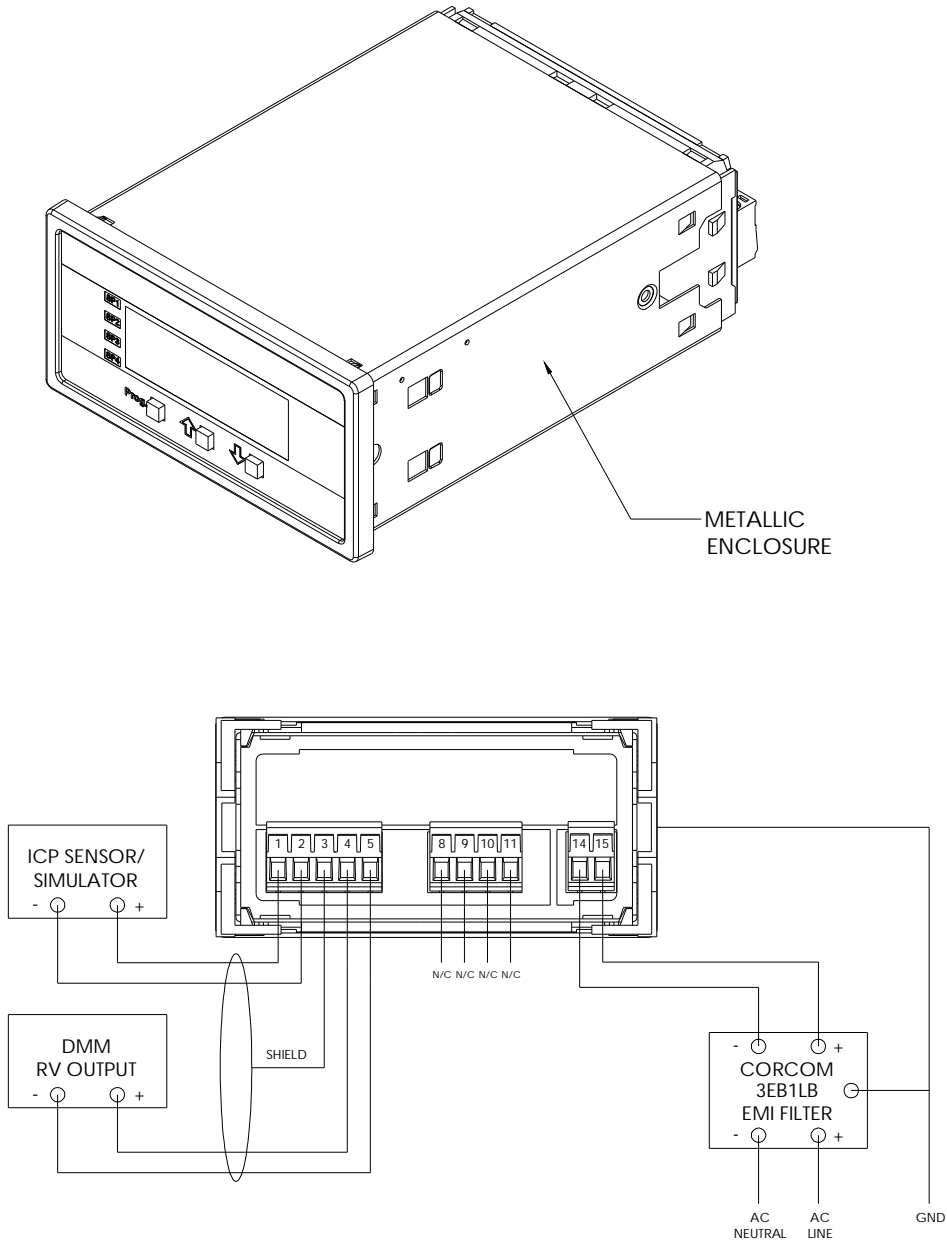

To Maintain Conformance I/O Shields must be connected to Pin 3 on the Panel Meter and all Supplied Accessories must be wired as shown (Power Supply Option 2).

Pin Descriptions

Input Signal - Pins 1 to 6

- Pin 1** +ICP[®] Sensor Excitation/Signal
- Pin 2** -ICP[®] Sensor Excitation
- Pin 3** ICP[®] Sensor Shield (if applicable)
- Pin 4** + RV Output (Analog Sensor Signal)
- Pin 5** - RV Output (Analog Sensor Signal)
- Pin 6** No Connection

Relay Output - Pins 8 to 12

- Pin 8** SP1 NO. (Normally Open 5 Amp Form A.)
- Pin 9** SP1 NO.
- Pin 10** SP2 NO. (Normally Open 5 Amp Form A.)
- Pin 11** SP2 NO.
- Pin 12** No Connection

AC/DC Power Unit - Pins 14 and 15

- Pin 14** AC/DC Neutral. Neutral power supply line.
- Pin 15** AC/DC Line. Live power supply line.

OPTIONAL TOP BOARD PINS

Analog Output - Pins 16 and 17

Pins 16 and 17 are the analog output pins on the optional output module.

- Pin 16** Positive (+) analog output.
- Pin 17** Negative (-) analog output.

Rear Panel Function – Pins 18 to 21

- Pin 18** DIM. By connecting the display dim (DIM) pin to the COMMON pin, the display brightness setting is halved.
- Pin 19** COMMON. To activate the LOCK or DIM functions from the rear of the meter, the respective pins have to be connected to the COMMON pin. This pin is connected to the internal power supply ground.
- Pin 20** HOLD. By connecting the HOLD pin to the COMMON pin, the display reading is frozen, however, A/D conversions continue. When the HOLD pin is disconnected from the COMMON pin, the correct reading is displayed.
- Pin 21** LOCK. By connecting the LOCK pin to the COMMON pin, the meter's parameters can be viewed but not changed.

Top Board Secondary Relay Output – Pins 22 to 29

Quad 5A Form A Relays or Dual 10Amp Form C Relays.

- Pin 22** SP1 (Quad 5A SPST Relay Option)
- Pin 23** SP1 (Quad 5A SPST Relay Option), SP3 COMM (10A SPDT Additional Relay Option)
- Pin 24** SP2 (Quad 5A SPST Relay Option), SP3 NC (10A SPDT Additional Relay Option)
- Pin 25** SP2 (Quad 5A SPST Relay Option), SP3 NO (10A SPDT Additional Relay Option)
- Pin 26** SP3 (Quad 5A SPST Relay Option)
- Pin 27** SP3 (Quad 5A SPST Relay Option), SP4 COMM (10A SPDT Additional Relay Option)
- Pin 28** SP4 (Quad 5A SPST Relay Option), SP4 NC (10A SPDT Additional Relay Option)
- Pin 29** SP4 (Quad 5A SPST Relay Option), SP4 NO (10A SPDT Additional Relay Option)

Case Dimensions and Panel Cutout

FRONT VIEW

1/8 DIN 96x48mm

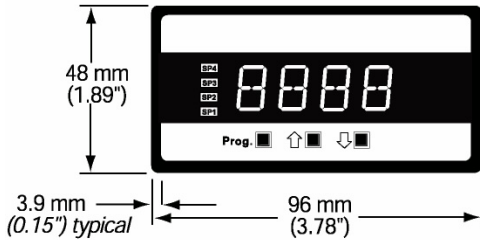

SIDE VIEW

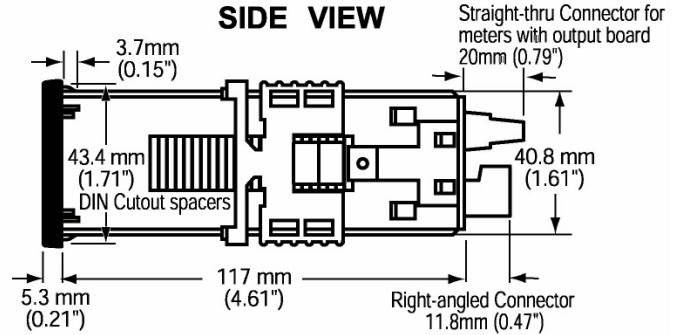

PANEL CUTOUT

Case will mount in standard 1/8 DIN cutouts

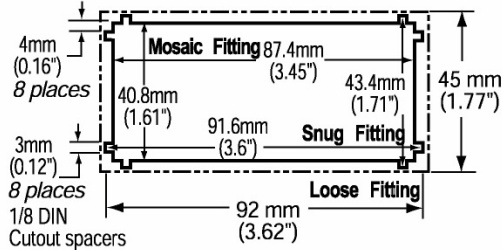

IMI's 96x48mm case is particularly suitable for mounting in mosaic panels or insulative panels up to 2" thick. They can also stack mount, 2 up in existing cutouts for 1/4 DIN (96x96mm) or 4 up in 1/2 DIN (96X192mm).

TOP VIEW

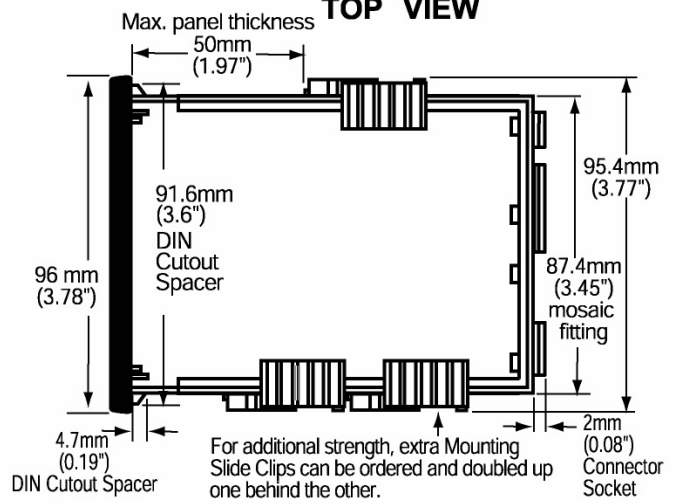

Configuring the 683A1

ICP® Interface PC Board Diagram

The ICP® Interface Board Diagram shows the location of the internal DIP switch. This DIP switch is used to configure the indicator for various sensor and vibration ranges. The PC Board is accessible through the back of the indicator by removing the Screw Terminal Plugs and back panel. The back panel is released by disengaging the tabs on the TOP and BOTTOM of the meter with a screwdriver. Once removed, the ICP® Interface Board can be slid out for configuration.

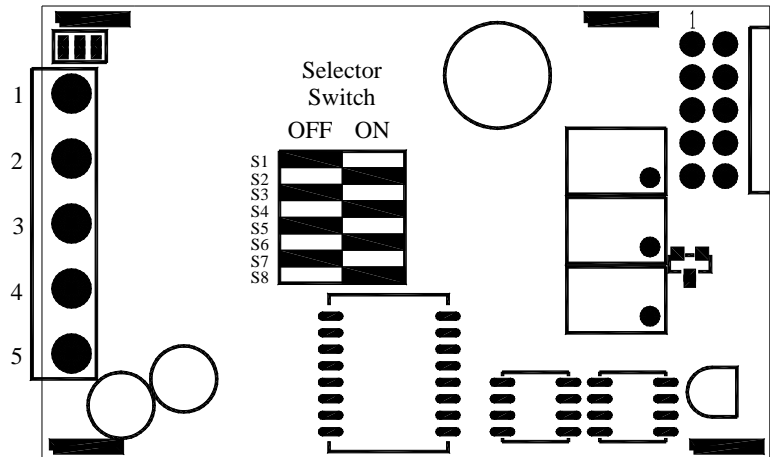

Internal DIP Switch Setting

The Internal DIP Switch of the Model 683A1 must be configured for the Full Scale Output of the ICP® Sensor connected to it. This is accomplished by removing the back cover and sliding the ICP® Interface PC Board out of the Panel Meter/Controller. Once removed, the DIP switch should be configured per one of the conditions in the following table.

Range Setting	S1	S2	S3	S4	S5	S6	S7	S8
5g RMS	ON	OFF	OFF	ON	OFF	OFF	OFF	ON
5g Peak	ON	OFF	OFF	OFF	ON	OFF	OFF	ON
10g RMS	ON	OFF	OFF	ON	OFF	OFF	ON	OFF
10g Peak	ON	OFF	OFF	OFF	ON	OFF	ON	OFF
20g RMS	ON	OFF	OFF	ON	OFF	ON	OFF	OFF
20g Peak	ON	OFF	OFF	OFF	ON	ON	OFF	OFF
0.5 in/sec RMS	OFF	ON	OFF	ON	OFF	OFF	OFF	ON
0.5 in/sec Peak	OFF	ON	OFF	OFF	ON	OFF	OFF	ON
1.0 in/sec RMS	OFF	ON	OFF	ON	OFF	OFF	ON	OFF
1.0 in/sec Peak	OFF	ON	OFF	OFF	ON	OFF	ON	OFF
2.0 in/sec RMS	OFF	ON	OFF	ON	OFF	ON	OFF	OFF
2.0 in/sec Peak	OFF	ON	OFF	OFF	ON	ON	OFF	OFF
25 mils p-p	OFF	OFF	ON	OFF	OFF	OFF	OFF	ON
50 mils p-p	OFF	OFF	ON	OFF	OFF	OFF	ON	OFF
100 mils p-p	OFF	OFF	ON	OFF	OFF	ON	OFF	OFF

Note: Factory Default Setting is 1.0in/sec Peak

Accessories

NEMA 4X Lens Cover

The lens cover is designed to be dust and water proof to NEMA-4X standards. The lens cover consists of a base and cover with a cam hinge and key-lock locking device.

An O-ring, or neoprene gasket forms a seal between the base and the panel. The cam hinge prevents the cover from closing when opened until pushed closed. The cover has a tapered recess that, when closed, forms a capillary seal with a tapered ridge on the base. Turning the key-lock tightens the cover to the base, insuring seal integrity. A safety catch keeps the cover closed even when the key is turned to the open position and removed. The keyhole can also be used to attach a safety seal clop, preventing unauthorized opening.

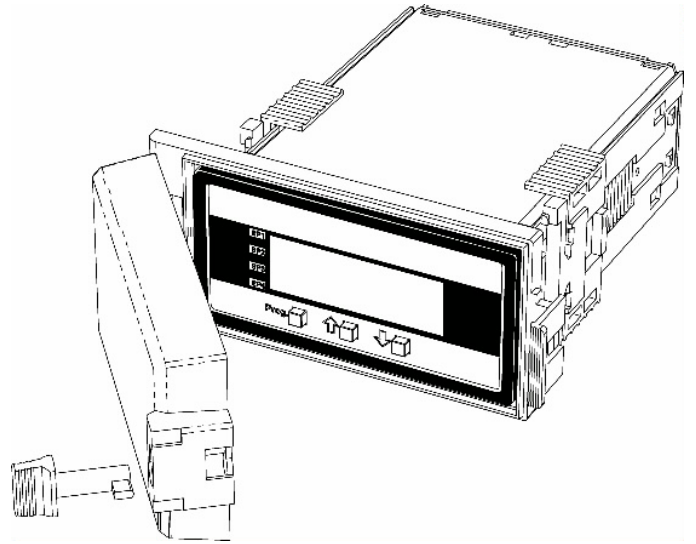

Metal Surround Case

The meter's plastic case is made from a fire retardant polycarbonate. A metal surround case can be ordered to enhance the meter's fire retardant capabilities and also provide shielding against electromagnetic interference (EMI). The metal case slides over the polycarbonate case and is held firmly in place by spring-type non-return clips. Once the metal case has been fitted to the polycarbonate case it cannot be removed.

With the metal case in place, the meter's plastic ratchet-type mounting clips can no longer be used. A pair of screw-type mounting clips are inserted into holes on the side of the metal case and used to mount the meter in the panel. A ground tab on the metal case provides a ground connection between the meter's main board and the metal case.

**Metal Surround Case must be factory installed.

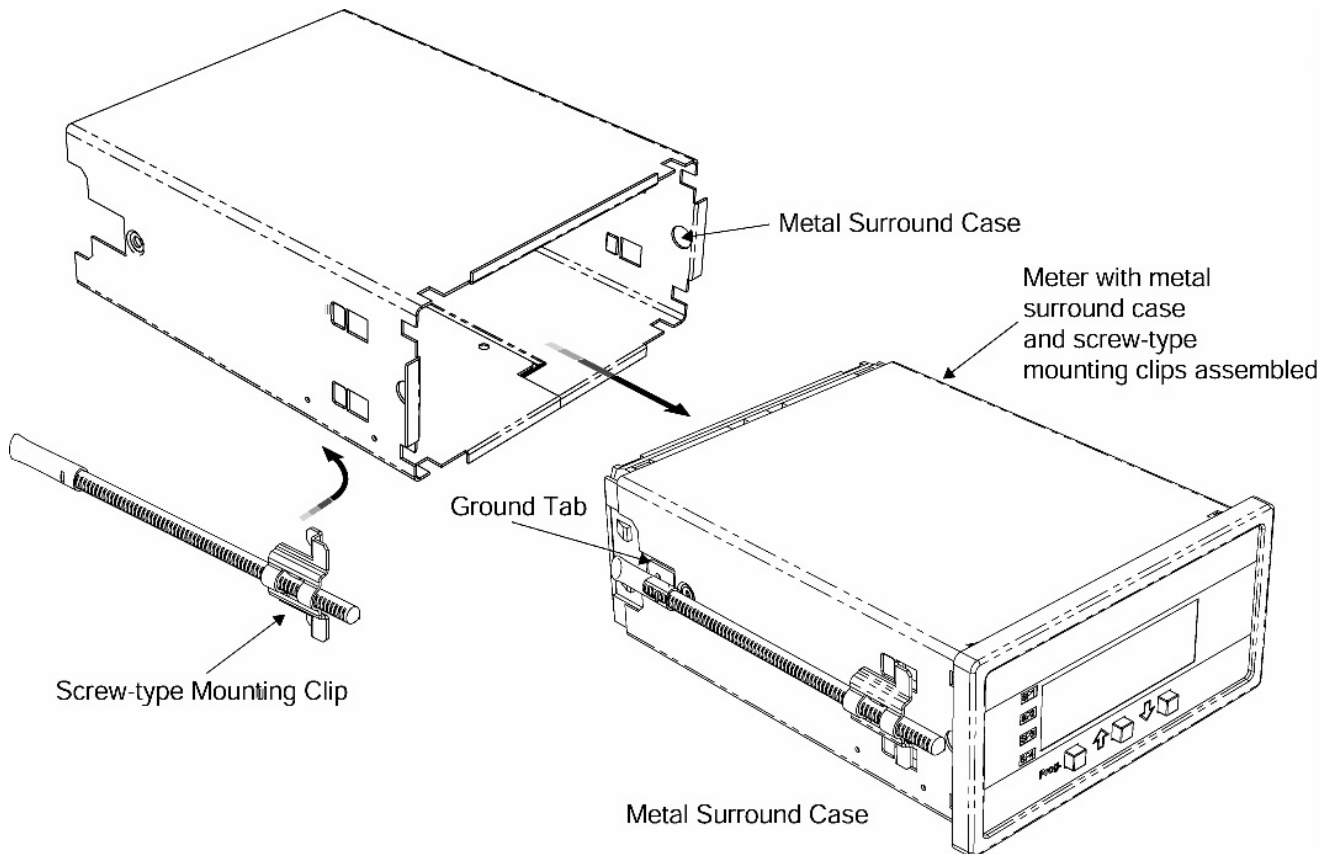

Warning 1 – ESD sensitivity

The power supply/signal conditioner should not be opened by anyone other than qualified service personnel. This product is intended for use by qualified personnel who recognize shock hazards and are familiar with the safety precautions required to avoid injury.

Warning 2 – ESD sensitivity

This equipment is designed with user safety in mind; however, the protection provided by the equipment may be impaired if the equipment is used in a manner not specified by PCB Piezotronics, Inc.

Caution 1 – ESD sensitivity

Cables can kill your equipment. High voltage electrostatic discharge (ESD) can damage electrical devices. Similar to a capacitor, a cable can hold a charge caused by triboelectric transfer, such as that which occurs in the following:

- *Laying on and moving across a rug,*
- *Any movement through air,*
- *The action of rolling out a cable, and/or*
- *Contact with a non-grounded person.*

The PCB solution for product safety:

- *Connect the cables only with the AC power off.*
- *Temporarily “short” the end of the cable before attaching it to any signal input or output.*

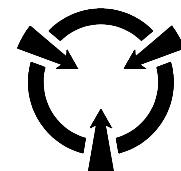

CAUTION
ELECTROSTATIC
DISCHARGE SENSITIVE

Caution 2 – ESD sensitivity

ESD considerations should be made prior to performing any internal adjustments on the equipment. Any piece of electronic equipment is vulnerable to ESD when opened for adjustments. Internal adjustments should therefore be done ONLY at an ESD-safe work area. Many products have ESD protection, but the level of protection may be exceeded by extremely high voltage.

Ordering Information

IMI Part Number: **683A 1 1 0 2 0 3**

Basic Model Number

683A

Sensor Input

1 100mV/g ICP[®] Sensor

Power Supply

0 85-265Vac/95-370Vdc
 1 18-48Vac/10-72Vdc
 2 85-265Vac/95-370Vdc CE Certified.

Analog Output*

0 None
 1 Isolated 16 bit user scalable 4-20mA retransmit.

Additional Relay Output*

0 None
 1 Dual 10 Amp Form C Relays (SPDT)
 2 Dual 5 Amp Form A Relays (SPST)

Frequency Response*

0 3Hz to 10kHz (Standard)
 1 3Hz to 1kHz
 2 10Hz to 10kHz
 3 10Hz to 1kHz

Accessories*

0 None
 1 96x48mm Clear Lockable Front Cover – NEMA 4X, Splash Proof.
 2 Metal Surround Case – Includes screw mounting clips.
 3 Clear Lockable Front Cover and Metal Surround Case.

Ordering Example: 683A100001

This is a standard ICP[®] Indicator/Controller with the following:

Power Supply: 85-265Vac/95-370Vdc

Analog Output: None

Additional Relay Output: None

Frequency Response: Standard (3Hz to 10kHz)

Accessories: 96x48mm Clear Lockable Front Cover – NEMA 4X, Splash Proof.

***Additional Options Available – Please Inquire**



Warranty

IMI instrumentation is warranted against defective material and workmanship for 1 year unless otherwise expressly specified. Damage to instruments caused by incorrect power or misapplication, is not covered by warranty. *If there are any questions regarding power, intended application, or general usage, please consult with your local sales contact or distributor.* Batteries and other expendable hardware items are not covered by warranty.

Service

Because of the sophisticated nature of IMI instrumentation, field repair is typically **NOT** recommended and may void any warranty. If factory service is required, return the instrumentation according to the "Return Procedure" stated below. *A repair and/or replacement quotation will be provided prior to servicing at no charge.* Before returning the unit, please consult a factory IMI applications engineer concerning the situation as certain problems can often be corrected with simple on-site procedures.

Return procedure

To expedite returned instrumentation, contact a factory IMI applications engineer for a RETURN MATERIAL AUTHORIZATION (RMA) NUMBER. Please have information available such as model and serial number. Also, to insure efficient service, provide a written description of the symptoms and problems with the equipment to a local sales representative or distributor, or contact IMI if none are located in your area.

Customers outside the U.S. should consult their local IMI distributor for information on returning equipment. For exceptions, please contact the International Sales department at IMI to request shipping instructions and an RMA. For assistance, please call (716) 684-0003, or fax us at (716) 684-3823. You may also receive assistance via e-mail at imi@pcb.com or visit our web site at www.pcb.com.



Customer Service

IMI, a division of PCB Piezotronics, guarantees **Total Customer Satisfaction**. If, at any time, for any reason, you are not completely satisfied with any IMI product, IMI will repair, replace, or exchange it at no charge. You may also choose, within the warranty period, to have your purchase price refunded.

IMI offers to all customers, at no charge, 24-hour phone support. This service makes product or application support available to our customers, day or night, seven days a week. When unforeseen problems or emergency situations arise, call the **IMI Hot Line at (716) 684-0003**, and an application specialist will assist you.



3425 Walden Avenue, Depew, NY 14043-2495
Phone: (716) 684-0003 • USA Fax: (716) 684-3823 • INTL Fax: (716) 684-4703

*ICP® is a registered trademark of PCB Group, Incorporated,
which uniquely identifies PCB sensors that incorporate built-in microelectronics.*

Model Number

684A01

SINGLE CHANNEL ENCLOSURE WITH BNC OUTPUT

Revision:

ECN #:

ELECTRICAL CHARACTERISTICS

Channels

ENGLISH

1

SI

1

PHYSICAL CHARACTERISTICS

Connectors:

- Input
- Output
- Raw Vibration
- Power

- Terminal Strip
- Terminal Strip
- BNC Jack
- Terminal Strip

- Terminal Strip
- Terminal Strip
- BNC Jack
- Terminal Strip

Terminal Strips

0.315 in Two Screw

8 mm Two Screw

Wire Size

12 to 24 AWG

3,31 to 0,205 mm²

Cord Grips:

- 5 PGME07
- 1 PGME13

- 5 PGME07
- 1 PGME13

Hole Plugs

10

10

Enclosure:

Type

Nema 4X

IP66

Size (H x W x D)

10 x 8 x 6 in

254 x 203 x 152 mm

Size (H x W x D) w/Meter, Grips, BNC

11.5 x 9 x 6.7 in

292 x 229 x 170 mm

Weight

4.2 lbs

1,9 kg

Weight w/Meter, Grips, BNC

4.9 lbs

2,2 kg

Panel Cutout (H x W)

1.715 x 3.615 in

43,6 x 91,8 mm

BNC Cutout

0.375 in dia

9,5 mm dia

OPTIONAL VERSIONS

Optional versions have identical specifications and accessories as listed for the standard model except where noted below. More than one option may be used.

-None-

NOTES:

None

SUPPLIED ACCESSORIES:

Mounting Kit

All specifications are at room temperature unless otherwise specified.

ICP® is a registered trademark of PCB Piezotronics, Inc.

In the interest of constant product improvement, we reserve the right to change specifications without notice.

Form DD030 Rev.F 2/23/99

Drawn: 	Engineer: <i>MJI</i>	Sales: <i>SGY</i>	Approved: <i>N.F</i>	Spec Number:
Date: <i>4/26/02</i>	Date: <i>4/26/02</i>	Date: <i>4/26/02</i>	Date: <i>4/26/02</i>	19279



3425 Walden Avenue, Depew, NY 14043

800-959-4464

Fax (716) 684-3823

E-Mail: imisales@pcb.com

Model Number
683A10000

INDICATOR / ALARM (FOR ICP® SENSORS)

Revision: B
ECN #: 49891

Performance

	ENGLISH	SI	
Sensor Input Type(s)	ICP®	ICP®	
Input Signal	100 mV/g	100 mV/(m/s ²)	
Frequency Response(± 3 dB)	3 to 10k Hz	3 to 10k Hz	
Channels	1	1	
Accuracy	± 2 % FS	± 2 % FS	
Measurement Range(Acceleration)	5 g	5 g	[1][2]
Measurement Range(Acceleration)	10 g	10 g	[1][2]
Measurement Range(Acceleration)	20 g	20 g	[1][2]
Measurement Range(Velocity)	0.50 in/sec	0.50 in/sec	[1][2]
Measurement Range(Velocity)	1.00 in/sec	1.00 in/sec	[1][2]
Measurement Range(Velocity)	2.00 in/sec	2.00 in/sec	[1][2]
Measurement Range(Displacement)	25.0 mil pk - pk	25.0 mil pk - pk	[1][2]
Measurement Range(Displacement)	50.0 mil pk - pk	50.0 mil pk - pk	[1][2]
Measurement Range(Displacement)	100.0 mil pk - pk	100.0 mil pk - pk	[1][2]
Relay Type(Alert)	5A Form A 230 VAC/30 VDC	5A Form A 230 VAC/30 VDC	
Relay Type(Alarm)	5A Form A 230 VAC/30 VDC	5A Form A 230 VAC/30 VDC	
Delay	0 to 9,999 sec	0 to 9,999 sec	

Environmental

Temperature Coefficient of Sensitivity	56 ppm/°F	100 ppm/°C
Warm Up	<2 minutes	<2 minutes
Temperature Range(Operating)	32 to 140 °F	0 to 60 °C
Temperature Range (Storage)	-4 to 158 °F	-20 to 70 °C
Humidity Range(Non-Condensing)	<95 %	<95 %

Electrical

Power Required(Auto Sensing)	85-265 VAC/95-370 VDC	85-265 VAC/95-370 VDC
Current Consumption(Typical)	2.5 W	2.5 W
Current Consumption (Max)	3.5 W	3.5 W
Excitation Voltage(± 1 VDC)	24 VDC	24 VDC
Constant Current Excitation(± 1 mA)	4 mA	4 mA

Physical

Size - Depth	4.61 in	117 mm
Size - Width	3.45 in	87.4 mm
Size - Height	1.61 in	40.8 mm
Housing Material	Polycarbonate	Polycarbonate
Weight	8.5 oz	241 gm
Din Rail Mount	1/8 in	3 mm
Electrical Connector	Removable Screw Terminals	Removable Screw Terminals
BEZEL	3.78 x 1.89 in	96 x 48 mm
Depth Behind BEZEL	4.61 in	117 mm
Depth Behind BEZEL (Rt. Angle Conn.)	5.08 in	129 mm
Depth Behind BEZEL (Straight Conn.)	5.40 in	137 mm
Accessories	None	None

OPTIONAL VERSIONS

Optional versions have identical specifications and accessories as listed for the standard model except where noted below. More than one option may be used.

NOTES:

- [1] Factory set, 1.0 in/sec peak
- [2] Internal Dip switch selectable
- [3] See PCB Declaration of Conformance PS050 for details.



All specifications are at room temperature unless otherwise specified.
In the interest of constant product improvement, we reserve the right to change specifications without notice.
ICP® is a registered trademark of PCB Piezotronics, Inc.

Entered: Ink	Engineer: JB	Sales: MC	Approved: NJF	Spec Number:
Date: 09/03/2019	Date: 09/03/2019	Date: 09/03/2019	Date: 09/03/2019	19278



3425 Walden Avenue, Depew, NY 14043

Phone: 800-959-4464
Fax: 716-684-3823
E-Mail: imi@pcb.com

APPLICATION		
NEXT ASS'Y	USED ON	VAR

PCB Piezotronics Inc. claims proprietary rights in the information disclosed hereon. Neither it nor any reproduction thereof will be disclosed to others without written consent of PCB Piezotronics Inc.

REVISIONS					
ZONE	REV	DESCRIPTION	ECN	DATE	APP'D

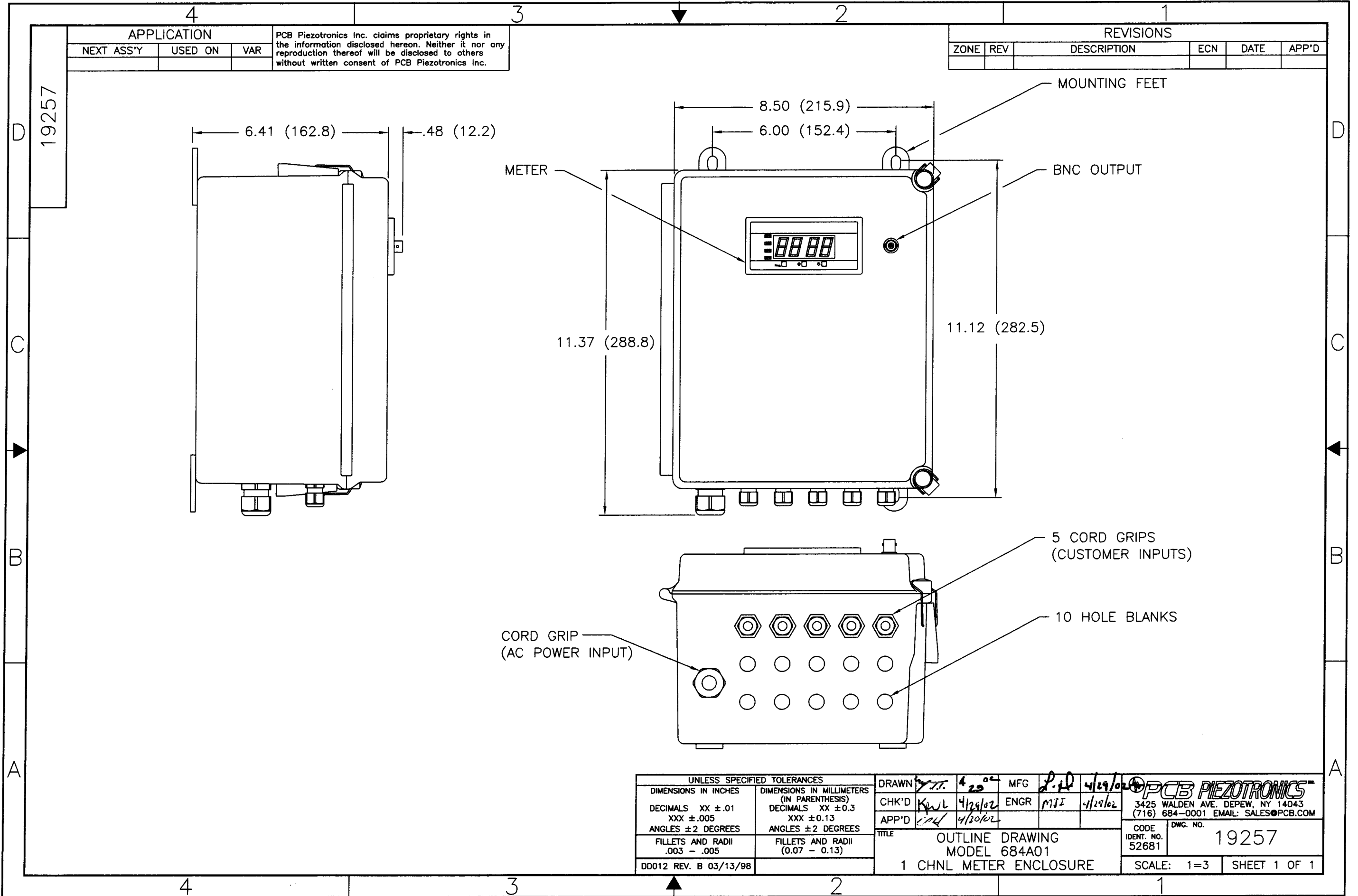

UNLESS SPECIFIED TOLERANCES	
DIMENSIONS IN INCHES	DIMENSIONS IN MILLIMETERS
DECIMALS XX ± .01	DECIMALS XX ± 0.3
XXX ± .005	XXX ± 0.13
ANGLES ± 2 DEGREES	ANGLES ± 2 DEGREES
FILLETS AND RADII .003 - .005	FILLETS AND RADII (0.07 - 0.13)

DRAWN <i>J.T.</i>	4/29/02	MFG <i>P.H.</i>	4/29/02
CHK'D <i>K.W.L.</i>	4/29/02	ENGR <i>M.S.E.</i>	4/29/02
APP'D <i>J.W.L.</i>	4/30/02		
TITLE OUTLINE DRAWING MODEL 684A01 1 CHNL METER ENCLOSURE			

PCB PIEZOTRONICS™	
3425 WALDEN AVE. DEPEW, NY 14043	
(716) 684-0001 EMAIL: SALES@PCB.COM	
CODE IDENT. NO. 52681	DWG. NO. 19257
SCALE: 1=3	SHEET 1 OF 1

DD012 REV. B 03/13/98

APPLICATION		
NEXT ASS'Y	USED ON	VAR
	683AXXXXXX	

PCB Piezotronics Inc. claims proprietary rights in the information disclosed hereon. Neither it nor any reproduction thereof will be disclosed to others without written consent of PCB Piezotronics Inc.

REVISIONS					
ZONE	REV	DESCRIPTION	ECN	DATE	APP'D
A1,D4	A	REVISED PER ECN	15596	6/20/02	dm6/02

18274

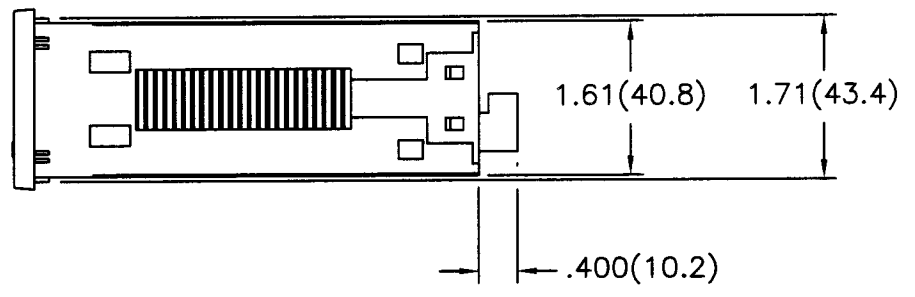
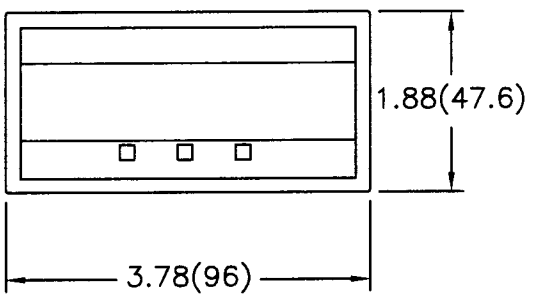
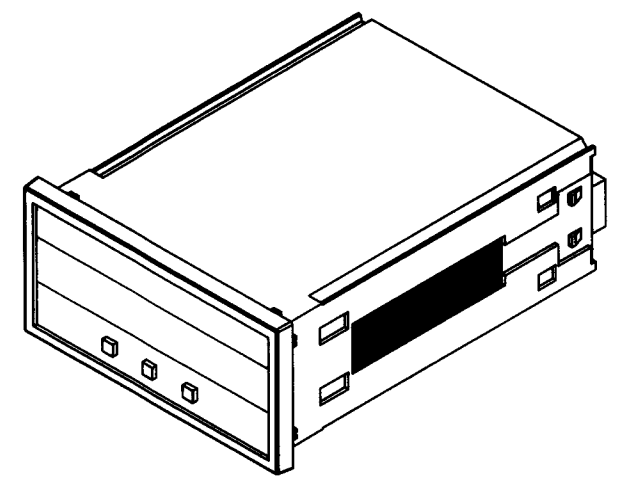
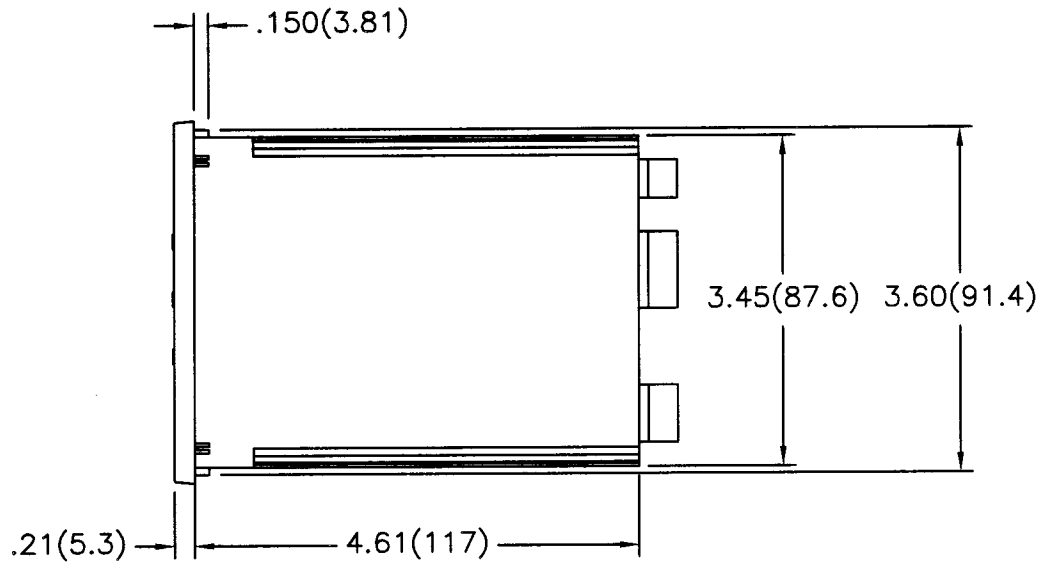

UNLESS SPECIFIED TOLERANCES	
DIMENSIONS IN INCHES	DIMENSIONS IN MILLIMETERS (IN PARENTHESIS)
DECIMALS XX ±.01	DECIMALS XX ±0.3
XXX ±.005	XXX ±0.13
ANGLES ±2 DEGREES	ANGLES ±2 DEGREES
FILLETS AND RADII .003 - .005	FILLETS AND RADII (0.07 - 0.13)
DD012 REV. B 03/13/98	

DRAWN	MVS 6/20/02	MFG	R.N. 6/24/02
CHK'D	om 6/21/02	ENGR	MJE 6/21/02
APP'D	N.F. 6/24/02	SALES	857 6/24/02
TITLE			
OUTLINE DRAWING MODEL 683AXXXXXX PANEL METER			

PCB PIEZOTRONICS	
3425 WALDEN AVE. DEPEW, NY 14043 (716) 684-0001 EMAIL: SALES@PCB.COM	
CODE IDENT. NO. 52681	DWG. NO. 18274
SCALE: 1 : 2	SHEET 1 OF 1