



Model 66213PPZ2

VOLTAGE OUTPUT TO-8 ACCELEROMETER

Installation and Operating Manual

**For assistance with the operation of this product,
contact PCB Piezotronics, Inc.**

**Toll-free: 800-959-4464
24-hour SensorLine: 716-684-0001
Fax: 716-684-3823
E-mail: imi@pcb.com
Web: www.imi-sensors.com**



Repair and Maintenance

PCB guarantees Total Customer Satisfaction through its “Lifetime Warranty Plus” on all Platinum Stock Products sold by PCB and through its limited warranties on all other PCB Stock, Standard and Special products. Due to the sophisticated nature of our sensors and associated instrumentation, **field servicing and repair is not recommended and, if attempted, will void the factory warranty.**

Beyond routine calibration and battery replacements where applicable, our products require no user maintenance. Clean electrical connectors, housings, and mounting surfaces with solutions and techniques that will not harm the material of construction. Observe caution when using liquids near devices that are not hermetically sealed. Such devices should only be wiped with a dampened cloth—never saturated or submerged.

In the event that equipment becomes damaged or ceases to operate, our Application Engineers are here to support your troubleshooting efforts 24 hours a day, 7 days a week. Call or email with model and serial number as well as a brief description of the problem.

Calibration

Routine calibration of sensors and associated instrumentation is necessary to maintain measurement accuracy. We recommend calibrating on an annual basis, after exposure to any extreme environmental influence, or prior to any critical test.

PCB Piezotronics is an ISO-9001 certified company whose calibration services are accredited by A2LA to ISO/IEC 17025, with full traceability to SI through N.I.S.T. In addition to our standard calibration services, we also offer specialized tests, including: sensitivity at elevated or cryogenic temperatures, phase response, extended high or low frequency response, extended range, leak testing, hydrostatic pressure testing, and others. For more information, contact your local PCB Piezotronics distributor, sales representative, or factory customer service representative.

Returning Equipment

If factory repair is required, our representatives will provide you with a Return Material Authorization (RMA) number, which we use to reference any information you have already provided and expedite the repair process. This number should be clearly marked on the outside of all returned package(s) and on any packing list(s) accompanying the shipment.

Contact Information

PCB Piezotronics, Inc.
3425 Walden Ave.
Depew, NY14043 USA
Toll-free: (800) 828-8840
24-hour SensorLine: (716) 684-0001
General inquiries: info@pcb.com
Repair inquiries: rma@pcb.com

For a complete list of distributors, global offices and sales representatives, visit our website, www.pcb.com.

Safety Considerations

This product is intended for use by qualified personnel who recognize shock hazards and are familiar with the precautions required to avoid injury. While our equipment is designed with user safety in mind, the protection provided by the equipment may be impaired if equipment is used in a manner not specified by this manual.

Discontinue use and contact our 24-Hour Sensorline if:

- Assistance is needed to safely operate equipment
- Damage is visible or suspected
- Equipment fails or malfunctions

For complete equipment ratings, refer to the enclosed specification sheet for your product.

Definition of Terms and Symbols

The following symbols may be used in this manual:



DANGER

Indicates an immediate hazardous situation, which, if not avoided, may result in death or serious injury.

**CAUTION**

Refers to hazards that could damage the instrument.

**NOTE**

Indicates tips, recommendations and important information. The notes simplify processes and contain additional information on particular operating steps.

The following symbols may be found on the equipment described in this manual:



This symbol on the unit indicates that high voltage may be present. Use standard safety precautions to avoid personal contact with this voltage.



This symbol on the unit indicates that the user should refer to the operating instructions located in the manual.



This symbol indicates safety, earth ground.



PCB工业监视和测量设备 - 中国RoHS2公布表

PCB Industrial Monitoring and Measuring Equipment - China RoHS 2 Disclosure Table

部件名称	有害物质					
	铅 (Pb)	汞 (Hg)	镉 (Cd)	六价铬 (Cr(VI))	多溴联苯 (PBB)	多溴二苯醚 (PBDE)
住房	0	0	0	0	0	0
PCB板	X	0	0	0	0	0
电气连接器	0	0	0	0	0	0
压电晶体	X	0	0	0	0	0
环氧	0	0	0	0	0	0
铁氟龙	0	0	0	0	0	0
电子	0	0	0	0	0	0
厚膜基板	0	0	X	0	0	0
电线	0	0	0	0	0	0
电缆	X	0	0	0	0	0
塑料	0	0	0	0	0	0
焊接	X	0	0	0	0	0
铜合金/黄铜	X	0	0	0	0	0
本表格依据 SJ/T 11364 的规定编制。						
0：表示该有害物质在该部件所有均质材料中的含量均在 GB/T 26572 规定的限量要求以下。						
X：表示该有害物质至少在该部件的某一均质材料中的含量超出 GB/T 26572 规定的限量要求。						
铅是欧洲RoHS指令2011/65/ EU附件三和附件四目前由于允许的豁免。						

CHINA RoHS COMPLIANCE

Component Name	Hazardous Substances					
	Lead (Pb)	Mercury (Hg)	Cadmium (Cd)	Chromium VI Compounds (Cr(VI))	Polybrominated Biphenyls (PBB)	Polybrominated Diphenyl Ethers (PBDE)
Housing	O	O	O	O	O	O
PCB Board	X	O	O	O	O	O
Electrical Connectors	O	O	O	O	O	O
Piezoelectric Crystals	X	O	O	O	O	O
Epoxy	O	O	O	O	O	O
Teflon	O	O	O	O	O	O
Electronics	O	O	O	O	O	O
Thick Film Substrate	O	O	X	O	O	O
Wires	O	O	O	O	O	O
Cables	X	O	O	O	O	O
Plastic	O	O	O	O	O	O
Solder	X	O	O	O	O	O
Copper Alloy/Brass	X	O	O	O	O	O

This table is prepared in accordance with the provisions of SJ/T 11364.

O: Indicates that said hazardous substance contained in all of the homogeneous materials for this part is below the limit requirement of GB/T 26572.

X: Indicates that said hazardous substance contained in at least one of the homogeneous materials for this part is above the limit requirement of GB/T 26572.

Lead is present due to allowed exemption in Annex III or Annex IV of the European RoHS Directive 2011/65/EU.

Model Number
66213PPZ2

3-WIRE TO-5 ACCELEROMETER

Revision: B
ECN #: 52695

Performance	ENGLISH	SI	
Sensitivity(± 20 %)	100 mV/g	10.2 mV/(m/s ²)	[1][2]
Measurement Range	± 20 g	± 200 m/s ²	[3]
Frequency Range(± 3 dB)	0.5 to 10k Hz	0.5 to 10k Hz	[4][5]
Resonant Frequency	> 25 kHz	> 25 kHz	[5]
Broadband Resolution	0.0017 g rms	0.016677 m/s ² rms	[6]
Non-Linearity	≤ 1 %	≤ 1 %	[7]
Transverse Sensitivity	≤ 7 %	≤ 7 %	
Environmental			
Overload Limit(Shock)	5,000 g pk	49k m/s ² pk	
Temperature Range(Operating)	-65 to +185 °F	-54 to +85 °C	
Temperature Response	See Graph	See Graph	[6]
Electrical			
Settling Time(within 1% of bias)	< 3 sec	< 3 sec	[6]
Discharge Time Constant	≥ 0.3 sec	≥ 0.3 sec	
Excitation Voltage	3 to 12 VDC	3 to 12 VDC	
Output Impedance	< 100 Ohm	< 100 Ohm	
Current Draw	.75 mA	.75 mA	[6]
Output Bias Voltage(± 10 %)	0.5 x Excitation Voltage	0.5 x Excitation Voltage	
Spectral Noise(10 Hz)	67 µg/√Hz	657 (µm/sec ²)/√Hz	[6]
Spectral Noise(100 Hz)	28 µg/√Hz	275 (µm/sec ²)/√Hz	[6]
Spectral Noise(1 kHz)	15 µg/√Hz	148 (µm/sec ²)/√Hz	[6]
Physical			
Size (Lip Diameter x Height)	0.36 in x 0.38 in	9.1 mm x 9.7 mm	
Weight	0.1 oz	3 gm	
Mounting	Adhesive	Adhesive	
Sensing Element	Ceramic	Ceramic	
Sensing Geometry	Shear	Shear	
Housing Material	Stainless Steel	Stainless Steel	
Sealing	Welded Hermetic	Welded Hermetic	
Electrical Connector	Integral Cable	Integral Cable	
Electrical Connection Position	Bottom	Bottom	
Cable Termination	Blunt cut	Blunt cut	
Electrical Connections(White)	Acceleration Output	Acceleration Output	
Electrical Connections(Red)	Pos (+) VDC	Pos (+) VDC	
Electrical Connections(Black)	Neg (-) Ground	Neg (-) Ground	
Cable Length	1 ft	0.3 m	
Cable Type	PVC	PVC	

OPTIONAL VERSIONS
Optional versions have identical specifications and accessories as listed for the standard model except where noted below. More than one option may be used.

HT - High temperature, extends normal operation temperatures		
Temperature Range(Operating)	-65 to 250 °F	-54 to 121 °C
Cable Type	010	010

RH - RoHS Compliant

NOTES:

- [1]Positive output along Z-axis (in upward direction when pin mounted).
- [2]Conversion Factor 1g = 9.81 m/s².
- [3]Measurement range achieved is dependent upon excitation voltage.
- [4]The high frequency tolerance is accurate within ±10% of the specified frequency.
- [5]Performance depends on mounting
- [6]Typical.
- [7]Zero-based, least-squares, straight line method.
- [8]See PCB Declaration of Conformance PS198

SUPPLIED ACCESSORIES:

Model ICS-2 NIST-traceable single-point amplitude response calibration at 6000 cpm (100 Hz) for each axis (1)

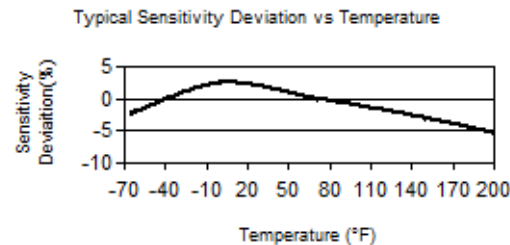

Entered: ND	Engineer: GD	Sales: JL	Approved: BAM	Spec Number:
Date: 05/24/2022	Date: 05/24/2022	Date: 05/24/2022	Date: 05/24/2022	56153



Phone: 800-959-4464
Fax: 716-684-3823
E-Mail: imi@pcb.com

All specifications are at room temperature unless otherwise specified.
In the interest of constant product improvement, we reserve the right to change specifications without notice.
ICP® is a registered trademark of PCB Piezotronics, Inc.

2

1

PCB Piezotronics Inc. claims proprietary rights in the information disclosed hereon. Neither it nor any reproduction thereof will be disclosed to others without the written consent of PCB Piezotronics Inc.

REVISIONS		
REV	DESCRIPTION	DIN
NR	RELEASED TO DRAFTING	35624

49903

B

B

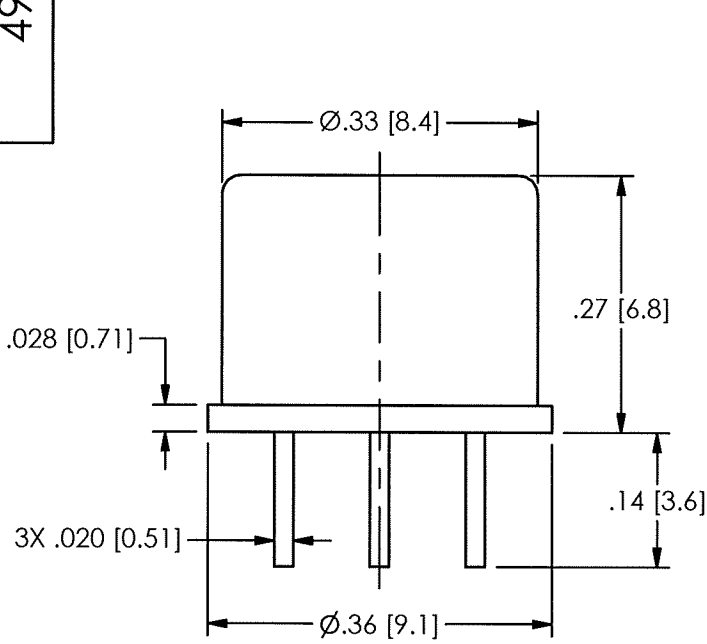

LOW PROFILE

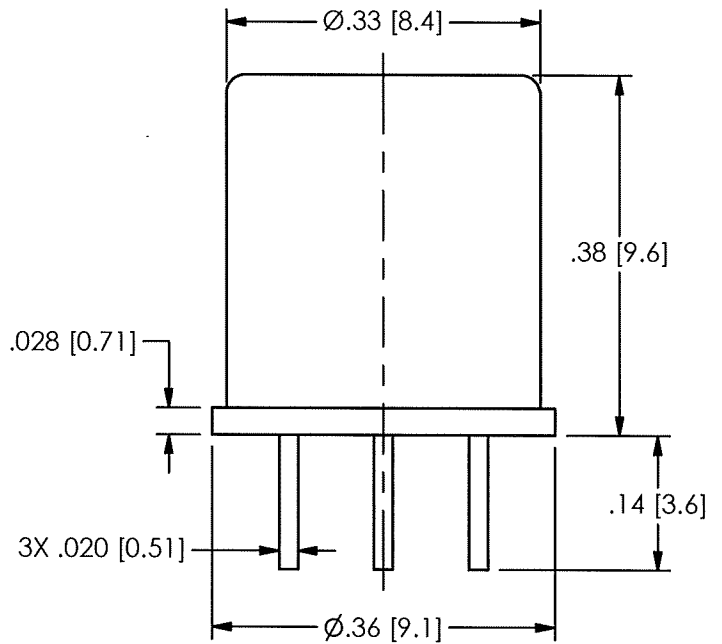

STANDARD PROFILE

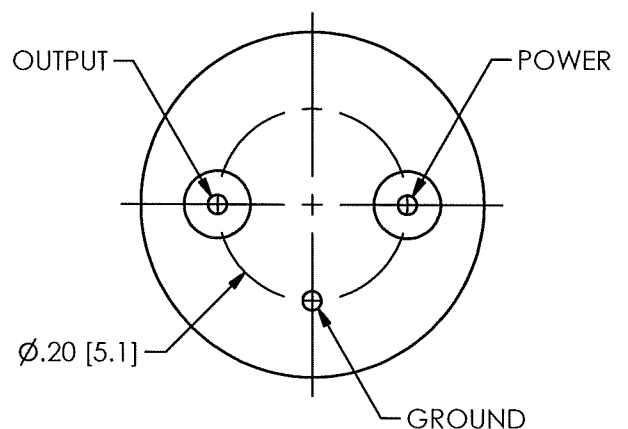
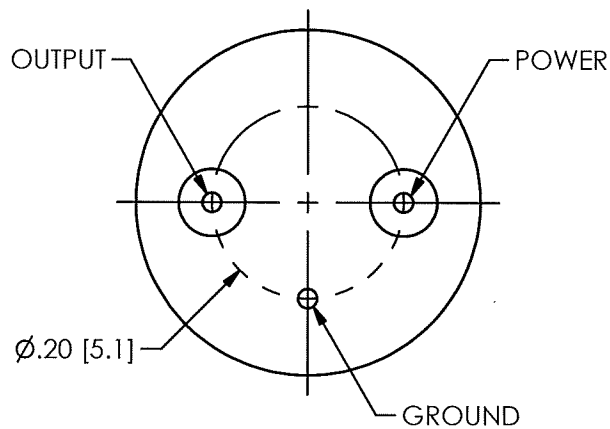

A

A

UNLESS OTHERWISE SPECIFIED TOLERANCES ARE:

DIMENSIONS IN INCHES

DECIMALS XX ±.03
XXX ±.010

ANGLES ± 2 DEGREES

FILLETS AND RADII
.003 - .005

DIMENSIONS IN MILLIMETERS
[IN BRACKETS]

DECIMALS X ± 0.8
XX ± 0.25

ANGLES ± 2 DEGREES

FILLETS AND RADII
0.07 - 0.13

DRAWN

NOF 5/5/11

CHECKED

ECB 5/5/11

ENGINEER

LAB 5/5/11

TITLE

OUTLINE DRAWING
MODEL 660 SERIES
3-WIRE ACCELEROMETER

PCB PIEZOTRONICS^{INC}

3425 WALDEN AVE. DEPEW, NY 14043
(716) 684-0001 E-MAIL: sales@pcb.com

CODE IDENT. NO.
52681

DWG. NO.

49903

SCALE: 5X

SHEET 1 OF 1

2

1