



Model 8180-SH311A

STATOR HEAD - SIGNAL RECEPTION ONLY W/10M CABLE

Installation and Operating Manual

**For assistance with the operation of this product,
contact PCB Piezotronics, Inc.**

**Toll-free: 800-828-8840
24-hour SensorLine: 716-684-0001
Fax: 716-684-0987
E-mail: info@pcb.com
Web: www.pcb.com**





Warranty, Service, Repair, and Return Policies and Instructions
--

The information contained in this document supersedes all similar information that may be found elsewhere in this manual.

Total Customer Satisfaction – PCB Piezotronics guarantees Total Customer Satisfaction. If, at any time, for any reason, you are not completely satisfied with any PCB product, PCB will repair, replace, or exchange it at no charge. You may also choose to have your purchase price refunded in lieu of the repair, replacement, or exchange of the product.

Service – Due to the sophisticated nature of the sensors and associated instrumentation provided by PCB Piezotronics, user servicing or repair is not recommended and, if attempted, may void the factory warranty. Routine maintenance, such as the cleaning of electrical connectors, housings, and mounting surfaces with solutions and techniques that will not harm the physical material of construction, is acceptable. Caution should be observed to insure that liquids are not permitted to migrate into devices that are not hermetically sealed. Such devices should only be wiped with a dampened cloth and never submerged or have liquids poured upon them.

Repair – In the event that equipment becomes damaged or ceases to operate, arrangements should be made to return the equipment to PCB Piezotronics for repair. User servicing or repair is not recommended and, if attempted, may void the factory warranty.

Calibration – Routine calibration of sensors and associated instrumentation is recommended as this helps build confidence in measurement accuracy and acquired data. Equipment calibration cycles are typically established by the users own quality regimen. When in doubt about a calibration cycle, a good “rule of thumb” is to recalibrate on an annual basis. It is also good practice to recalibrate after exposure to any severe temperature extreme, shock, load, or other environmental influence, or prior to any critical test.

PCB Piezotronics maintains an ISO-9001 certified metrology laboratory and offers calibration services, which are accredited by A2LA to ISO/IEC 17025, with full traceability to SI through N.I.S.T. In addition to the normally supplied calibration, special testing is also available, such as: sensitivity at elevated or cryogenic temperatures, phase response, extended high or low frequency response, extended range, leak testing, hydrostatic pressure testing, and others. For information on standard recalibration services or special testing, contact your local PCB Piezotronics distributor, sales representative, or factory customer service representative.

Returning Equipment – *Following these procedures will insure that your returned materials are handled in the most expedient manner.* Before

returning any equipment to PCB Piezotronics, contact your local distributor, sales representative, or factory customer service representative to obtain a Return **Warranty, Service, Repair, and Return Policies and Instructions** Materials Authorization (RMA) Number. This RMA number should be clearly marked on the outside of all package(s) and on the packing list(s) accompanying the shipment. A detailed account of the nature of the problem(s) being experienced with the equipment should also be included inside the package(s) containing any returned materials.

A Purchase Order, included with the returned materials, will expedite the turn-around of serviced equipment. It is recommended to include authorization on the Purchase Order for PCB to proceed with any repairs, as long as they do not exceed 50% of the replacement cost of the returned item(s). PCB will provide a price quotation or replacement recommendation for any item whose repair costs would exceed 50% of replacement cost, or any item that is not economically feasible to repair. For routine calibration services, the Purchase Order should include authorization to proceed and return at current pricing, which can be obtained from a factory customer service representative.

Warranty – All equipment and repair services provided by PCB Piezotronics, Inc. are covered by a limited warranty against defective material and workmanship for a period of one year from date of original purchase. Contact

PCB for a complete statement of our warranty. Expendable items, such as batteries and mounting hardware, are not covered by warranty. Mechanical damage to equipment due to improper use is not covered by warranty. Electronic circuitry failure caused by the introduction of unregulated or improper excitation power or electrostatic discharge is not covered by warranty.

Contact Information – International customers should direct all inquiries to their local distributor or sales office. A complete list of distributors and offices can be found at www.pcb.com. Customers within the United States may contact their local sales representative or a factory customer service representative. A complete list of sales representatives can be found at www.pcb.com. Toll-free telephone numbers for a factory customer service representative, in the division responsible for this product, can be found on the title page at the front of this manual. Our ship to address and general contact numbers are:

PCB Piezotronics, Inc.
3425 Walden Ave.
Depew, NY14043 USA
Toll-free: (800) 828-8840
24-hour SensorLineSM: (716) 684-0001
Website: www.pcb.com
E-mail: info@pcb.com



PCB工业监视和测量设备 - 中国RoHS2公布表
 PCB Industrial Monitoring and Measuring Equipment - China RoHS 2 Disclosure Table

部件名称	有害物质					
	铅 (Pb)	汞 (Hg)	镉 (Cd)	六价铬 (Cr(VI))	多溴联苯 (PBB)	多溴二苯醚 (PBDE)
住房	○	○	○	○	○	○
PCB板	X	○	○	○	○	○
电气连接器	○	○	○	○	○	○
压电晶体	X	○	○	○	○	○
环氧	○	○	○	○	○	○
铁氟龙	○	○	○	○	○	○
电子	○	○	○	○	○	○
厚膜基板	○	○	X	○	○	○
电线	○	○	○	○	○	○
电缆	X	○	○	○	○	○
塑料	○	○	○	○	○	○
焊接	X	○	○	○	○	○
铜合金/黄铜	X	○	○	○	○	○
本表格依据 SJ/T 11364 的规定编制。						
○：表示该有害物质在该部件所有均质材料中的含量均在 GB/T 26572 规定的限量要求以下。						
X：表示该有害物质至少在该部件的某一均质材料中的含量超出 GB/T 26572 规定的限量要求。						
铅是欧洲RoHS指令2011/65/ EU附件三和附件四目前由于允许的豁免。						

CHINA RoHS COMPLIANCE

Component Name	Hazardous Substances					
	Lead (Pb)	Mercury (Hg)	Cadmium (Cd)	Chromium VI Compounds (Cr(VI))	Polybrominated Biphenyls (PBB)	Polybrominated Diphenyl Ethers (PBDE)
Housing	O	O	O	O	O	O
PCB Board	X	O	O	O	O	O
Electrical Connectors	O	O	O	O	O	O
Piezoelectric Crystals	X	O	O	O	O	O
Epoxy	O	O	O	O	O	O
Teflon	O	O	O	O	O	O
Electronics	O	O	O	O	O	O
Thick Film Substrate	O	O	X	O	O	O
Wires	O	O	O	O	O	O
Cables	X	O	O	O	O	O
Plastic	O	O	O	O	O	O
Solder	X	O	O	O	O	O
Copper Alloy/Brass	X	O	O	O	O	O

This table is prepared in accordance with the provisions of SJ/T 11364.

O: Indicates that said hazardous substance contained in all of the homogeneous materials for this part is below the limit requirement of GB/T 26572.

X: Indicates that said hazardous substance contained in at least one of the homogeneous materials for this part is above the limit requirement of GB/T 26572.

Lead is present due to allowed exemption in Annex III or Annex IV of the European RoHS Directive 2011/65/EU.

DOCUMENT NUMBER: 21354

DOCUMENT REVISION: C

ECN: 45605

System Components	<u>ENGLISH</u>	<u>SI</u>	[1]
Model	Stator Head Rcv Only	Stator Head Rcv Only	
Environmental			
Temperature Range	32 to 140 °F	0 to 60 °C	
Electrical			
Typical Air Gap	1.6 ft	500 mm	
Physical			
Size (Height x Length x Width)	0.217 in x 0.945 in x 0.472 in	5.5 mm x 24 mm x 12 mm	
Weight	0.1 oz	3 g	
Cable Length(Captive)	1 ft	0.3 m	
Cable Length(Extension)	32 ft	10 m	
Mounting	No English Equivalent	M3	
Mounting(Alternate)(Application Dependant)	Glue or double sided adhesive tape	Glue or double sided adhesive tape	

*All specifications are at room temperature unless otherwise specified.
In the interest of constant product improvement, we reserve the right to change specifications without notice.
ICP® is a registered trademark of PCB Group, Inc.*

OPTIONAL VERSIONS

Optional versions have identical specifications and accessories as listed for the standard model except where noted below. More than one option may be used.

8180-SH100 - Large Inductive Head - Typ. Air Gap 40mm/1.58in

8180-SH11X - Large Inductive Head with Ext. Cable

8180-SH200 - Small Inductive Head - Typ. Air Gap 10mm/0.4in

8180-SH21X - Small Inductive Head with Ext. Cable

8180-SH400 - Loop Head - 350mm to 650mm/13.8in to 25.6in

8180-SH41X - Loop Head with Ext. Cable

NOTES:
[1]This model requires the use of an 8180-CUXXA - Control Unit, an 8180-REXXA - Rotor unit, and an extension cable.

REQUIRED ACCESSORIES:
 Model 8180-CU0XD Control Unit with display, DIN rail mounting
 Model 8180-CUXXA Control Unit with display, standard mounting
 Model 8180-RE102A Single channel telemetry transmitter, strain gage input for full and half bridges, 19.5 MHz carrier
 Model 8180-RE103A PCB L&T Single channel telemetry rotor electronics for strain, 23 MHz
 Model 8180-RE110A PCB L&T Single channel telemetry transmitter for strain gage input, 10.7 MHz, Extended temperature range of -40 to 248 F (-40 to 120 C)
 Model 8180-RE112A
 Model 8180-RE113A

Entered: AP	Engineer: PE	Sales: RM	Approved: JM	Spec Number:
Date: 1/6/2015	Date: 1/6/2015	Date: 1/6/2015	Date: 1/6/2015	60336

PCB Load & Torque, Inc.
24350 Indoplex Circle
Farmington Hills, MI 48335
UNITED STATES
Phone: 866-684-7107
Fax: 716-684-0987
E-Mail: Itinfo@pcbloadtorque.com
Web site:
<http://www.pcbloadtorque.com>



PCB LOAD & TORQUE
A PCB GROUP COMPANY

60343

PCB Load & Torque (A Division of PCB Piezotronics, Inc.)
claims proprietary rights in the information disclosed hereon.
Neither it nor any reproduction thereof will be disclosed to
others without the written consent of PCB Load and Torque.

REVISIONS		
REV	DESCRIPTION	ECO
NR	RELEASED FOR PRODUCTION - 12.02.14, PTE	43567

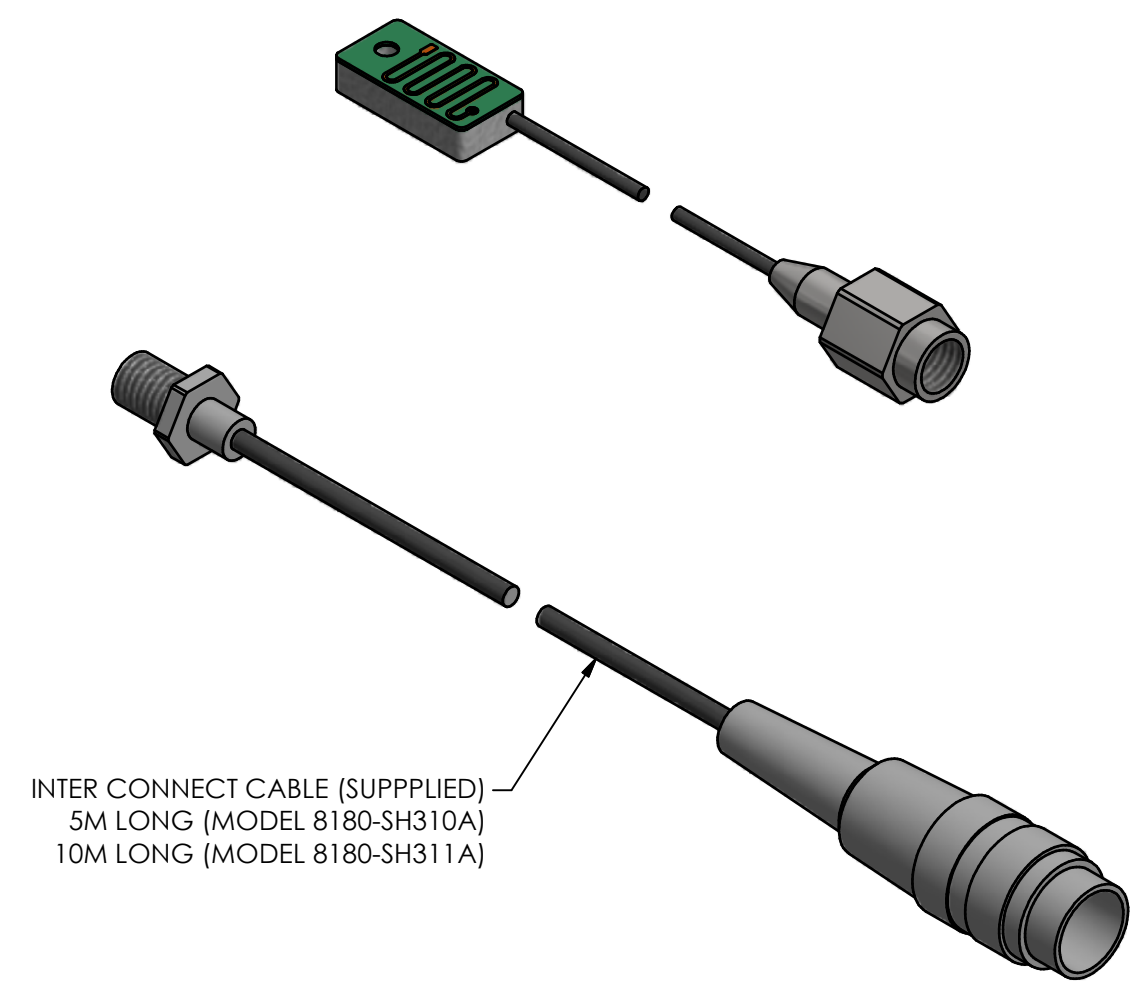
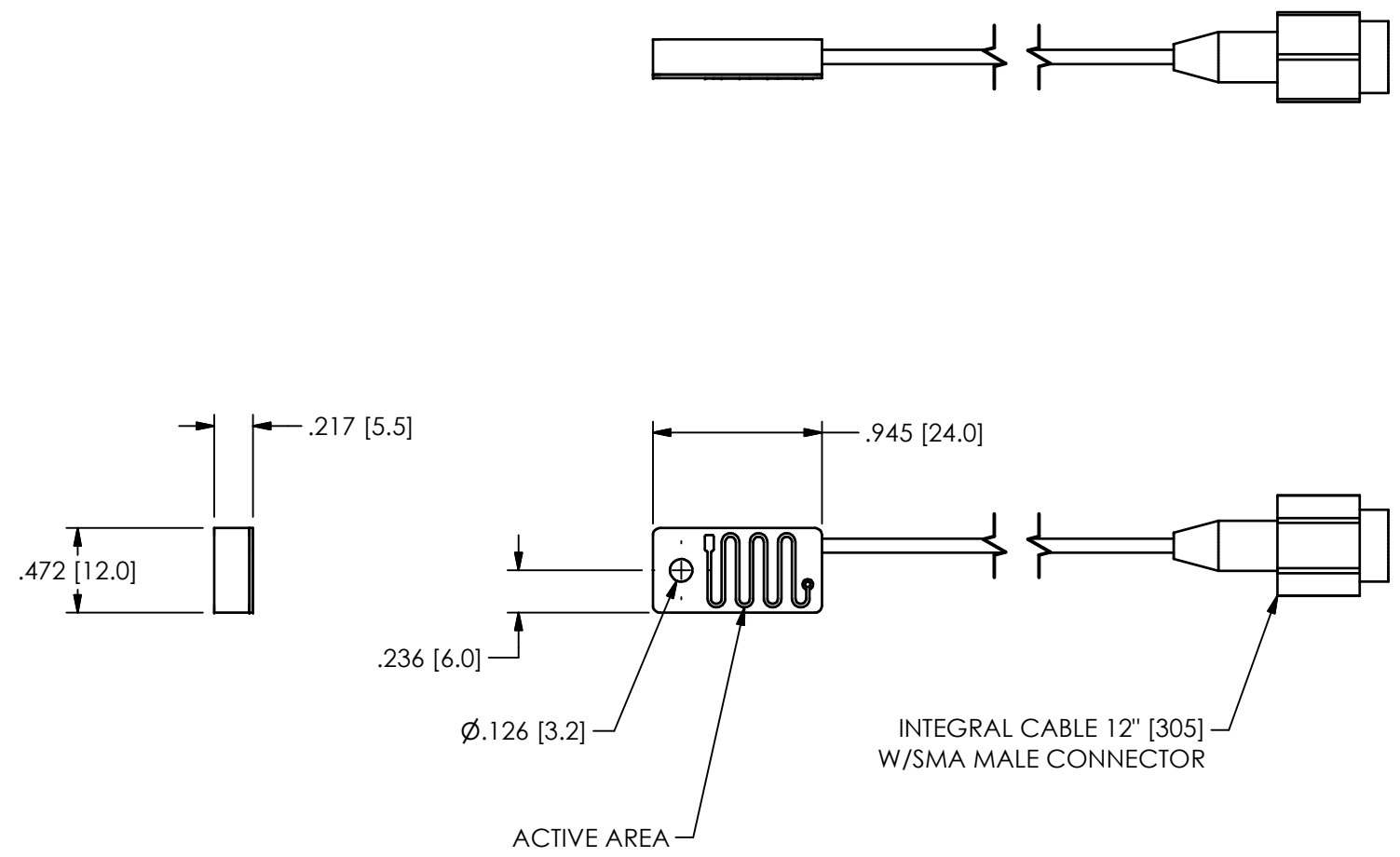

UNLESS OTHERWISE SPECIFIED TOLERANCES ARE:		DRAWN		CHECKED		ENGINEER		 PCB LOAD & TORQUE <small>A PCB GROUP COMPANY</small> 24350 Indoplex Circle, Farmington Hills, MI 48335 (248) 888-8260 E-MAIL: liinfo@pcb.com DWG. NO. 60343 SCALE: FULL SHEET 1 of 1
DIMENSIONS IN INCHES	DIMENSIONS IN MILLIMETERS [IN BRACKETS]	PTE	12.02.14	SAC	12.02.14	SAC	12.02.14	
DECIMALS XX ±.01 XXX ±.005	DECIMALS X ± 0.3 XX ± 0.13	TITLE OUTLINE DRAWING RECEIVING HEAD 8180-SH3XXA SERIES						
ANGLES ± .5 DEGREES	ANGLES ± .5 DEGREES							
FILLETS AND RADII .015 MAX	FILLETS AND RADII 0.38 MAX							

Model 8180

Single channel Telemetry



A simple, accurate method of conditioning and transmitting strain, thermocouple, voltage or ICP® signals from moving or rotating components.

Model 8180

Contents

	Page
Important Safety Tips	1
Important Installation Tips	2
Technical Data	3
Basic System Configuration	4
Rotor Electronics 8180-RE1	5
Rotor Electronics 8180-RE1 (Overview)	6
Power the 8180-RE1	7
Inductive /Receiving Heads 8180-Sh	8
Telemetry Cable	13
Control Unit 8180-CU	14
Shunt Calibration	16
Installation of Antenna	17
Installation Kit 8180-IK00A	19
CE Approved	20

Abbreviations

TC	Thermocouple	STG	Strain Gage	n	RPM
Mt	Torque	AC	Alternating Current	DC	Direct Current

Units of physical dimensions

Voltage	1V = 1,000mV
Current	1A = 1,000mA
Weight	1kg = 1,000g = 35.275 oz.
Temperature	°C = degrees Celsius
	°F = degrees Fahrenheit
	°K = degrees Kelvin
Length	1m = 1,000mm = 3.28ft = 39.37"
Torque	1Nm = 8.851in.lbf



Important Safety Tips!

The 8180 single channel telemetry system utilizes an inductive electricity supply.

Avoid having combustible material in the area of the inductive head.

The power oscillator is regulated according to power usage.

With high power demand the inductive head can become hot to the touch, up to 60°C/140°F.

With high power use the Control Unit can become warm to touch and should be located in a well ventilated area.

Potential health hazard for heart pacemakers.

The inductive supply system generates a magnetic field.

Heart pacemakers and other sensitive medical devices should stay clear of the magnetic field. This area is 50cm/20" around the inductive head.

Potential Burn Hazard.

Avoid metallic objects in and around the active magnetic field. Such as rings, chains and other metallic jewelry. These objects become very hot and burn the skin.

Electrical Shock Hazard.

The Control Unit should not be opened except by authorized service personal. High voltages of up to 400V_{pp} can be found in the Control Unit and stator head cable. Any damaged or frayed stator cables should be discarded and replaced immediately as they may pose a shock hazard.

It is the responsibility of the user to ensure the rotor electronics and antenna are properly installed on the shaft.

Components not correctly mounted may come loose during operation and cause injury to personnel and damages to components and property.

Important Installation Tips!

8180 Installation

All cable connections should be done with the power off.

Only apply power to the Control unit with a stator head connected, otherwise damage to the Control Unit may occur.

If the inductive head is placed on a metallic surface with the power on, the power oscillator will produce maximum power. While there is circuitry to prevent the system from being damaged for a short period of time, this must be avoided.

The inductive head should be fastened to a non-metallic plate or bracket. If a metallic bracket is used the stator should be isolated from the metal by more than 5 mm of a non metallic material such as rubber or plastic.

Mounting the stator near or on metal could produce unnecessary warming of the stator head and cause damage to the system. Every attempt should be made to keep a metal free area around the stator head for best operation.

The installation of the 8180 single channel telemetry system requires the rotor electronics and antenna be mounted in such a way they do not come loose during operation.

It is the responsibility of the user to ensure the components of the 8180 single channel telemetry system are properly installed.

Knowledge of basic soldering techniques is required.

Soldering should be preformed using a regulated soldering iron. The recommended temperature setting is 400 °C / 752 °F.

Model 8180

Technical data

Single-Channel-Telemetry		8180
Rotor electronics 8180-RE		
Mechanical values		
	housing	nickel-plated aluminum housing dust tight and waterproof
	Mechanical adaptation	installation on shafts with tape, glue and/or resins
	weight; dimensions	3g / 0.1oz.; 40mm x 12mm x 3.5mm / 1.57" x 0.47" x 0.14"
	Maximum RPM	dependent on installation, up to 50,000 RPM; higher on request
Operating temperature		-40°C...120°C/ -40°F...248°F, not condensing
Power supply		Battery 6...18V/ 17mA; Inductive supply with module 8180-SH0 8180-SH000A module allows distances of up to 2m/6.6ft to the antenna
Sensor connection		Solder pads
Data transmission		integrated RF-transmitter; 10.7 MHz <1mW
Transmitting antenna		Dependent on application, single band around shaft
Signal input		differential amplifier for direct connection of sensors
	Configuration	by solder jumpers or resistor
	Sensors	different models for specific sensors 8180-RE1- STG full-bridge / half-bridge >=350 Ohm ; 8180-RE2 - TC Type K (non-isolated) ; 8180-RE3 - ICP
	Strain gage bridge excitation	3VDC, integrated, short circuit protected
	Measurement ranges	±0.5mV/V, ±2mV/V, set by jumper or ±0.1mV/V... ±16mV/V, adjustable -100°C .. 1,000°C/-148°F..1,832°F, linearized, cold junction compensated
	Accuracy	Better than ±0.1% FS or ±1°K
	Signal bandwidth	1,000 Hz / channel
	Linearity	< 0.1%
	Zero and Gain drift	-10°C...80°C/14°F...176°F < 0.001%/K; ...100°C/212°F < 0.002%/K -40°... 120°C/-40°F...248°F < 0.003%/K
	Anti-aliasing filter	Butterworth, integrated
	Adjustment function	Offset ±1.8V and gain ±20% by potentiometer at control unit
	Control function	Shunt calibration for STG-application ; power on negative full scale if TC break
Stator 8180-SH		
Wideband Inductive/Receiving head	8180-SH1 8180-SH2 8180-SH4	5m/16ft Telemetry cable; Transmission distance dependent on installation maximum 40mm/1.7"; dimensions 35 x 50 x 70 mm ³ maximum 10mm/0.4"; dimensions 25 x 30 x 45 mm ³ 500mm/19.7" loop length; longer lengths are available
Wideband Receiving head	8180-SH3	0.1m...2m /0.3ft..6.5ft. dependent on installation, dimensions 24 x 12 x 5.5 mm ³ ; 0.95"x 0.47"x 0.22"
Control unit 8180-CU0		
Signal output	-analog voltage -analog frequency	BNC jack on front panel, ±10V BNC jack on front panel, 10kHz ±5kHz
Display		3½ digit LCD-Display
RF-Receiver		integrated,
Power supply		9... 32VDC, with inductive power supply about 12W
dimensions (LxWxH); Weight		robust compact housing 180 x 105 x 64 mm ³ / 7.09"x 4.13"x 2.54"; 1 kg / 35oz. Rack mounting is possible 19"/3HU plug-in
Operating temperature		0°C...60°C/32°F...140°F
Options/special accessories		
	Telemetry cable	5m/16ft - 009M192/M05 ; 10m/32ft - 009M192/M010 ; 20m/64ft - 009M192/M020
	Installation Kit	Installation Kit 8180-IK00A : copper band, mu-metal, Isolation tape
	Special	Carrier frequencies other than 10.7MHz are available Other than type K thermocouples, are available upon request

In the interest of constant product improvement, we reserve the right to change specifications without notice

Model 8180

Basic System Installation

Example: torque measure on a rotating shaft with strain gage, full bridge

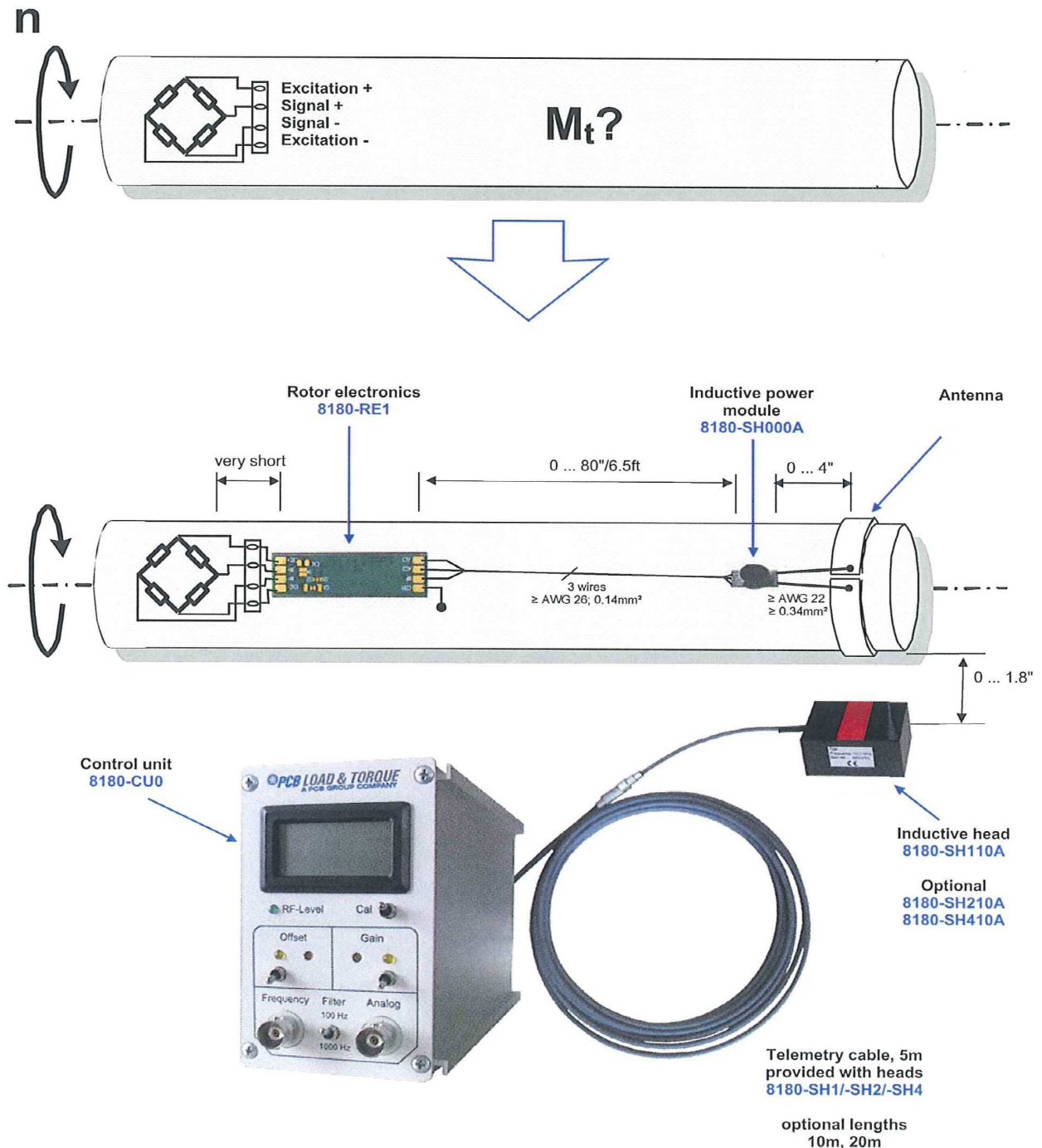

Model 8180

Rotor electronics 8180-RE1

Rotor electronics for Strain gage Full or Halfbridge, $\geq 350\Omega$

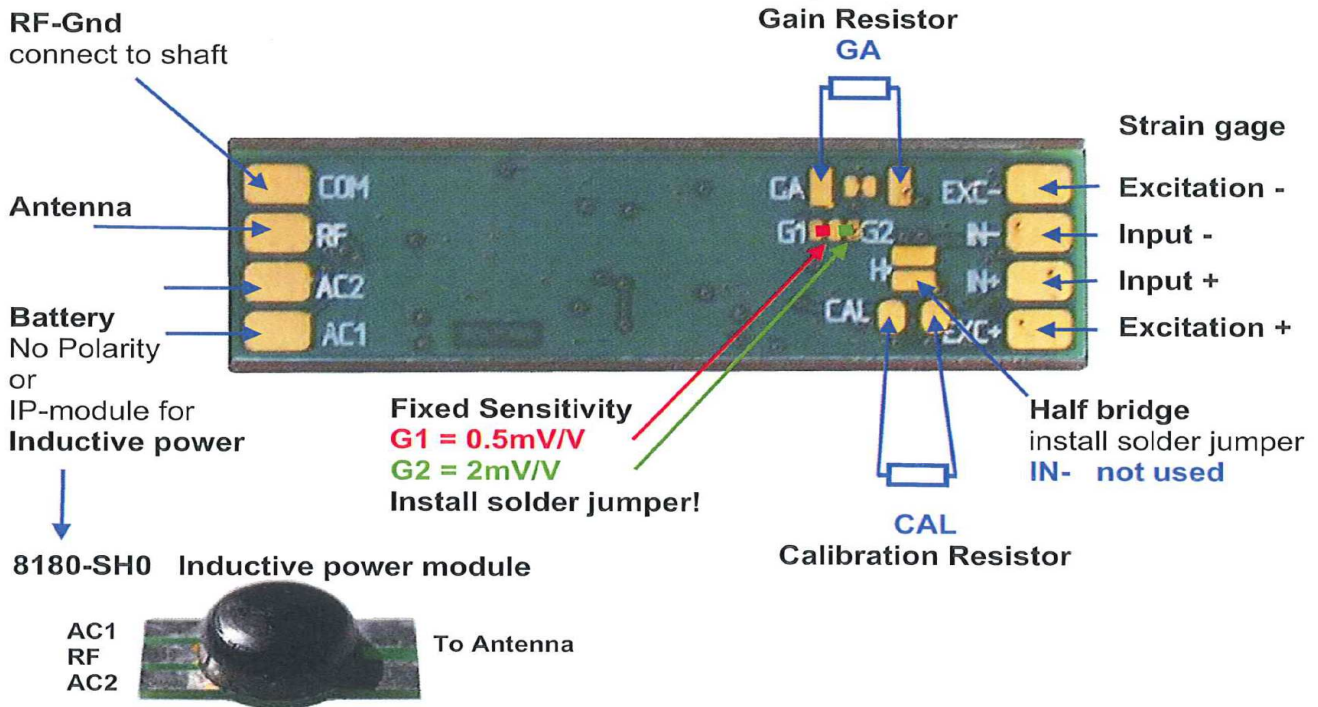

Calculation

Gain resistor GA (soldered resistor)

$$GA = 100 / (125 / (3 * S) 1) \quad [k\Omega]$$

Calibration resistor CAL (soldered resistor)

$$CAL = Rb (25000 / (D * S) 0.5) \quad [k\Omega]$$

Units S = Sensitivity [mV/V];

Rb = Bridge Resistor [kΩ];

D = Shunt [%]

Sensitivity [mV/V]	0.1	0.5	1.0	2.0	4.0	8.0
GA [kΩ]	0.241	1.215	2.459	5.042	10.619	23.762
CAL [kΩ] 80% Shunt 350Ω bridge	1,093.575	218.575	109.200	54.512	27.169	13.497

Useful Link for calculation

<http://www.rt-m.de/dl/singlecal-pcb.jnlp>

Model 8180

Rotor Electronics 8180-RE1 Overview

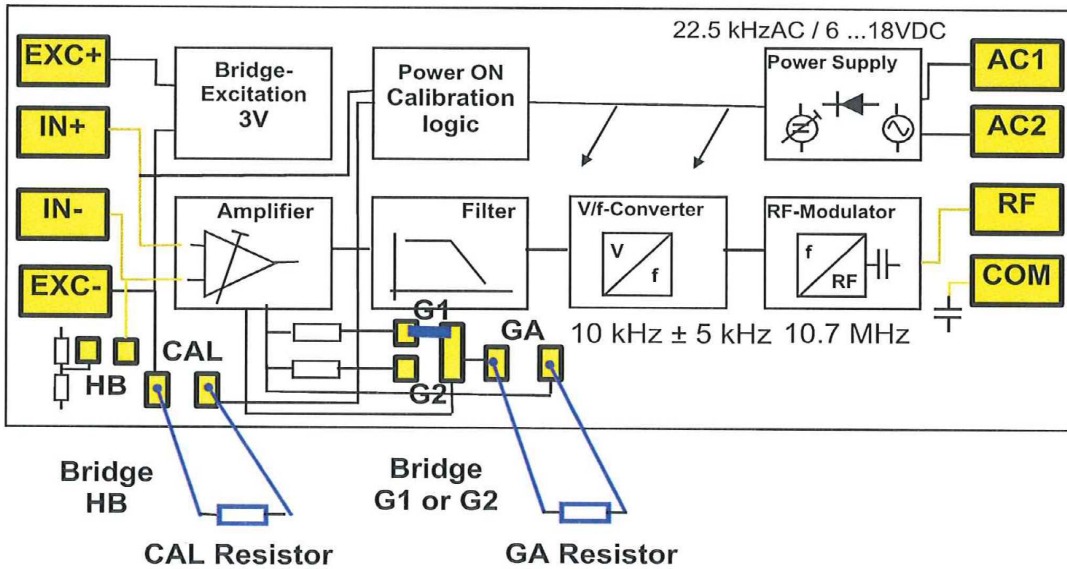
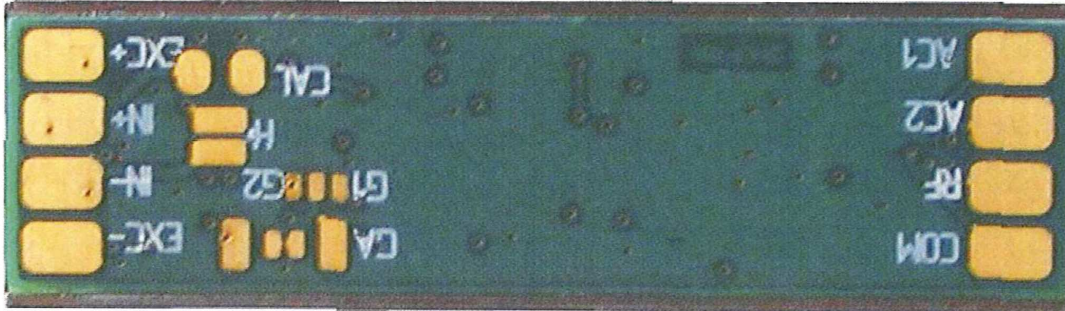

Rotor electronics 8180-RE1

Input connection

Full bridge

Half bridge

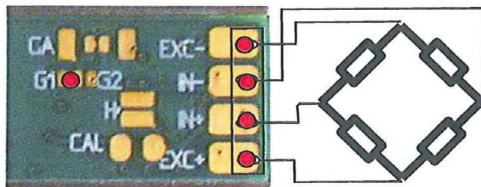

example 0.5mV/V

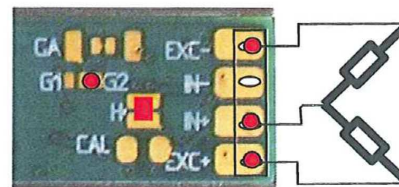

example 1mV/V

Model 8180

Powering the Rotor electronics 8180-RE1 DC Supply

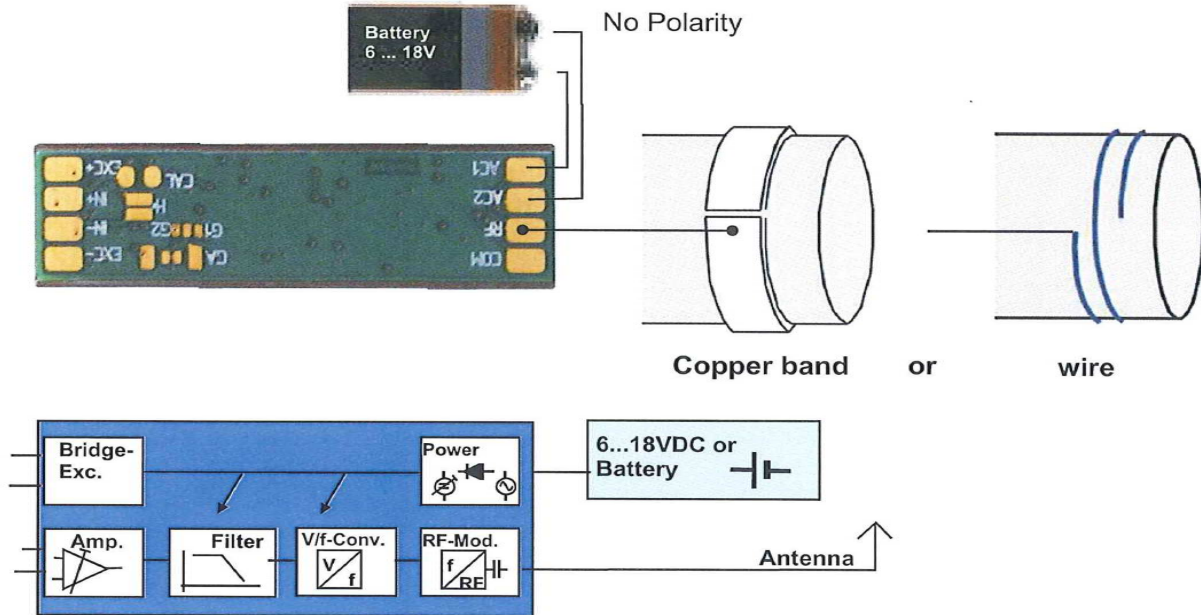

AC Supply

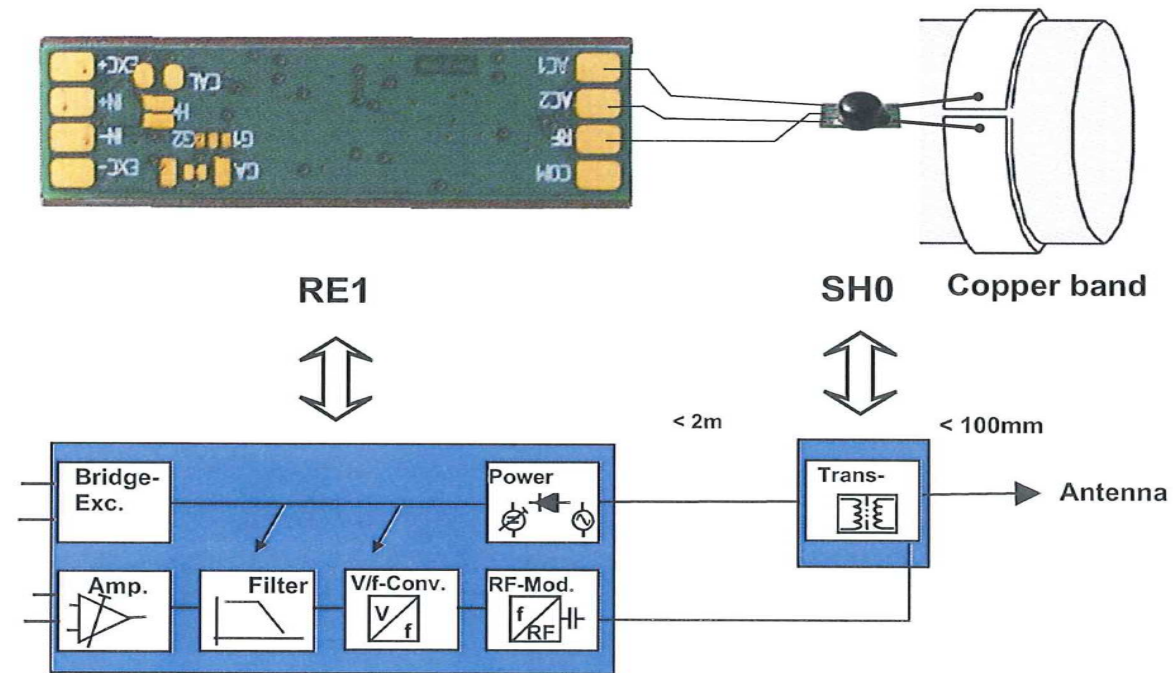

Model 8180

Inductive / Receiving Heads 8180-SH

All heads **8180-SH** have an integrated active antenna.
Frequency range: 10 MHz to 40 MHz.

The **8180-SH310A** head is designed for use with battery power and has no integrated coil system for inductive power supply.

8180-SH410A
Loop Head

8180-SH110A
Large Head

8180-SH210A
Small Head

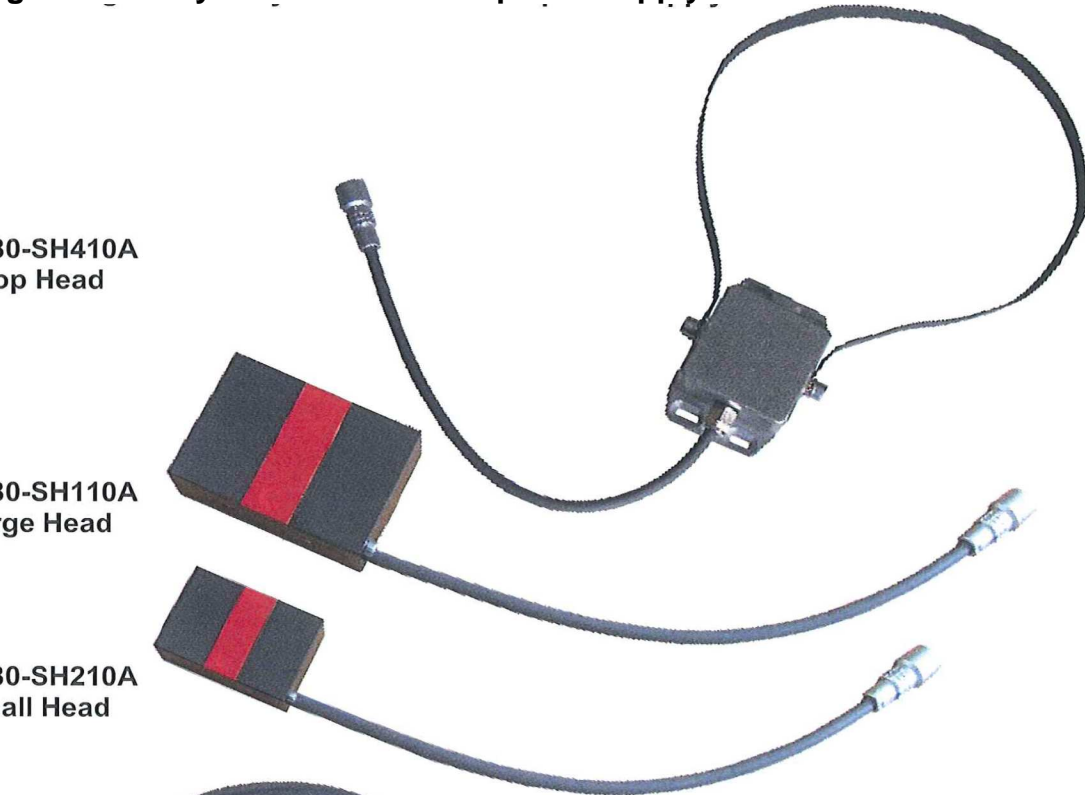

009M192/M05
Telemetry cable 5m / 16ft standard

009M192/M010
Telemetry cable 10m / 32ft

009M192/M020
Telemetry cable 20m / 64ft

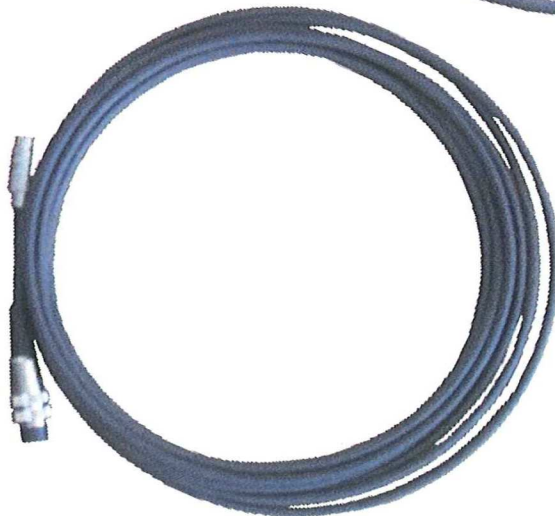

8180-SH310A
Receiving Head
(Battery Operation Only)



Model 8180

Inductive head 8180-SH110A “Large Head” Typical air gap 40 mm / 1.58”

The inductive head should be fastened to a non-metallic plate or bracket. If a metallic bracket is used the stator should be isolated from the metal by more than 5 mm of a non metallic material such as rubber or plastic.

Mounting the stator near or on metal could produce unnecessary warming of the stator head and cause damage to the system. Every attempt should be made to keep a metal free area around the stator head for best operation.

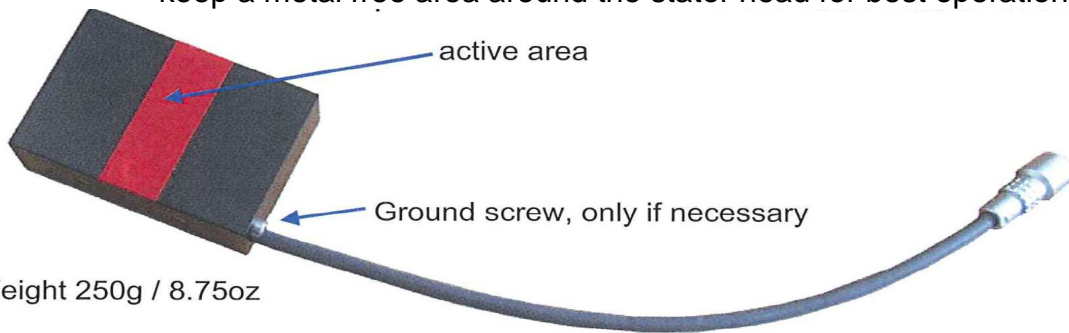

Weight 250g / 8.75oz

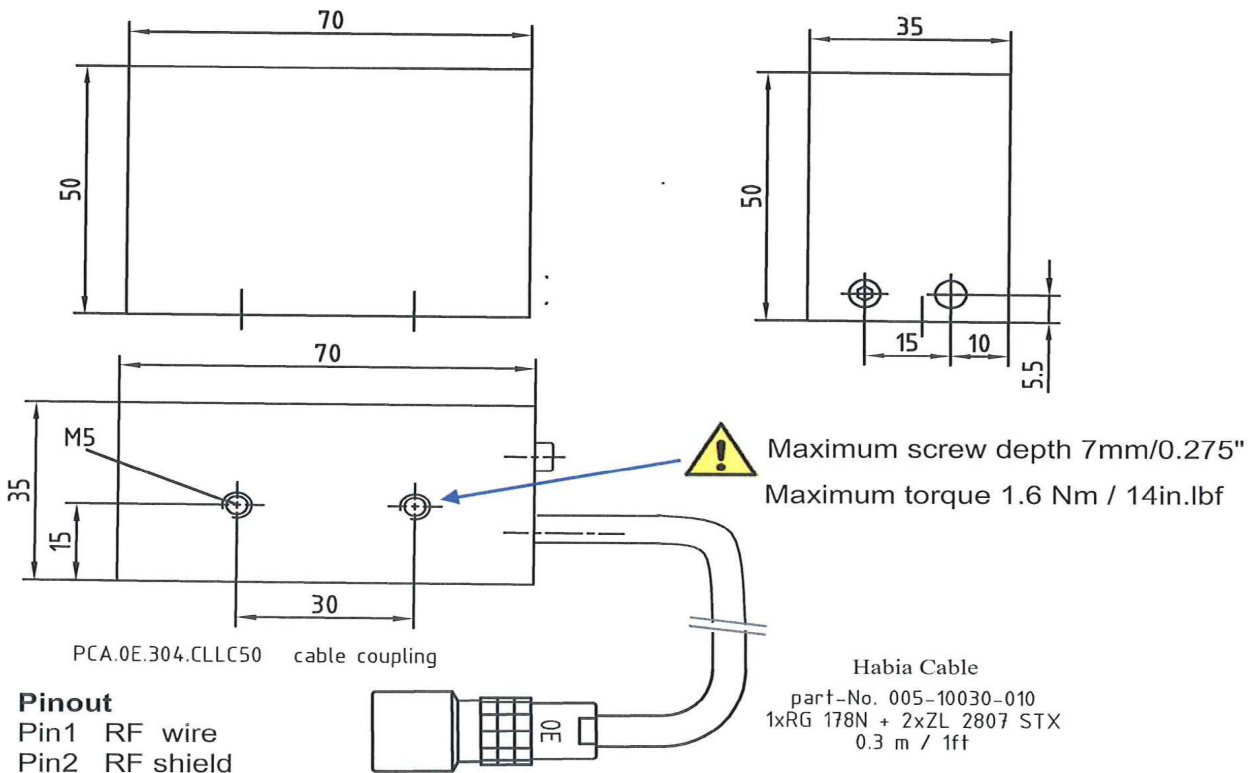

drawing dimensions in mm

Model 8180

Inductive head 8180-SH210A “Small Head” Typical air gap 10 mm / 0.4”

The inductive head should be fastened to a non-metallic plate or bracket. If a metallic bracket is used the stator should be isolated from the metal by more than 5 mm of a non metallic material such as rubber or plastic.

Mounting the stator near or on metal could produce unnecessary warming of the stator head and cause damage to the system. Every attempt should be made to keep a metal free area around the stator head for best operation.

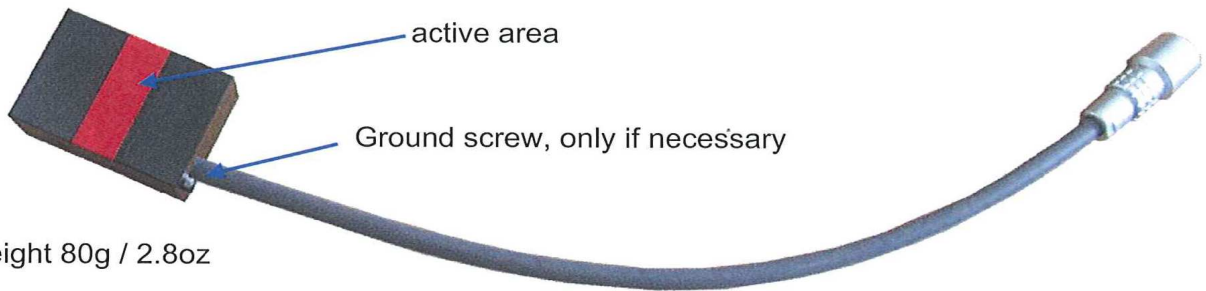

Weight 80g / 2.8oz

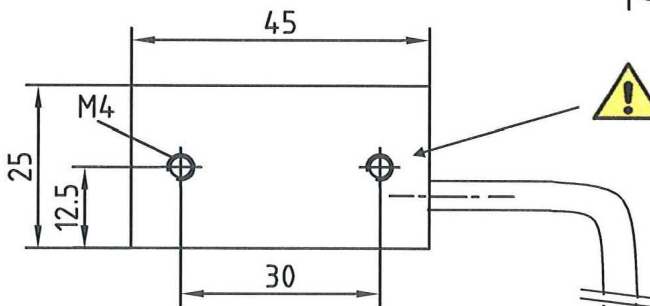
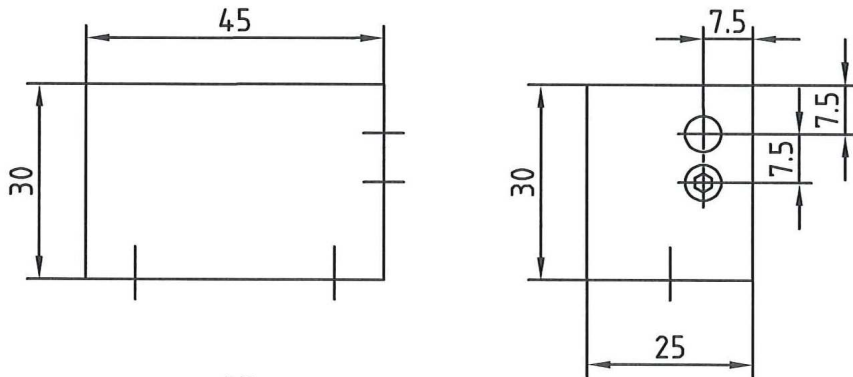

! Maximum screw depth 6mm/0.236"
Maximum torque 1.3 Nm / 11in.lbf

- Pinout**
- Pin1 RF wire
 - Pin2 RF shield
 - Pin3 Power1
 - Pin4 Power2

PCA.0E.304.CLLC50 cable coupling

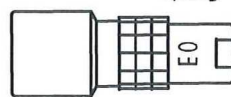

Habia Cable
part-No. 005-10030-010
1xRG 178N + 2xZL 2807 STX
0.3 m / 1ft

Drawing dimensions in mm

Model 8180

Inductive head 8180-SH410A “Loop Head” Typical loop length 350mm...650mm / 13.8”...25.6”

Loop material:

standard and recommended: Copper band 0.3 mm x 10 mm; 0.12" x 0.39"
Included Loop length: 500mm / 19.7"

Screws:



Allen-head screw; M5 x 10mm
The screws should be torqued to 2.5 Nm / 22 in.lbf

It is very important the contact area of the loop and screws be clean during assembly and should be cleaned with sandpaper.

To improve the connection a lock washer and washer should be used.

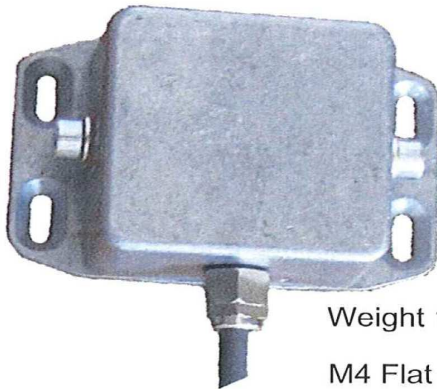

Weight 191g / 6.69oz
M4 Flat headed screw

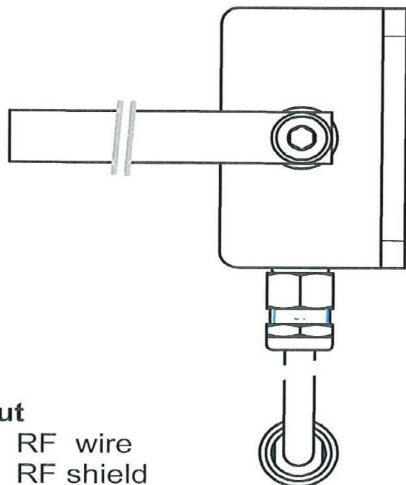

Pinout

- Pin1 RF wire
- Pin2 RF shield
- Pin3 Power1
- Pin4 Power2

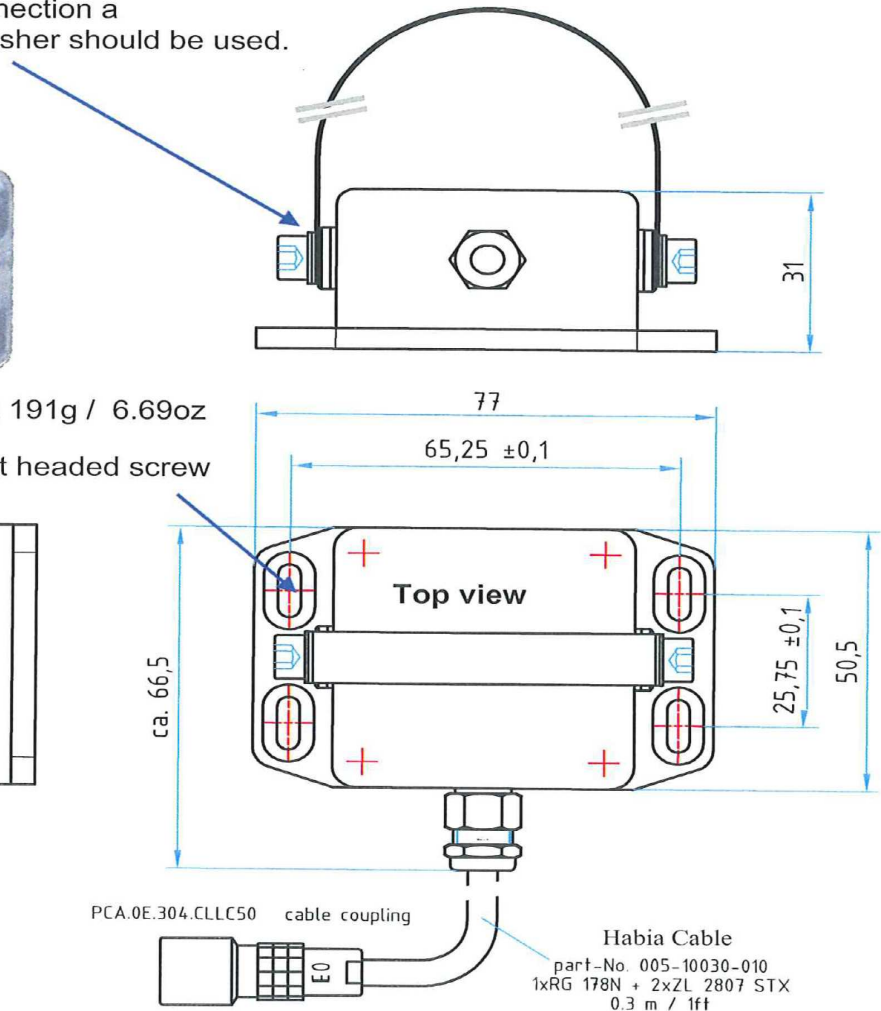

Drawing dimensions in mm

Model 8180

Receiving head 8180-SH310A “Antenna Head” Typical receiving distance 500mm/ 1.6ft

The receiving head is designed for use with battery powered installations. It is not possible to inductively power the rotor electronics with the 8180-SH310A Head.

While plug in the original connecting cable into the Control Unit the power oscillator is not switched on

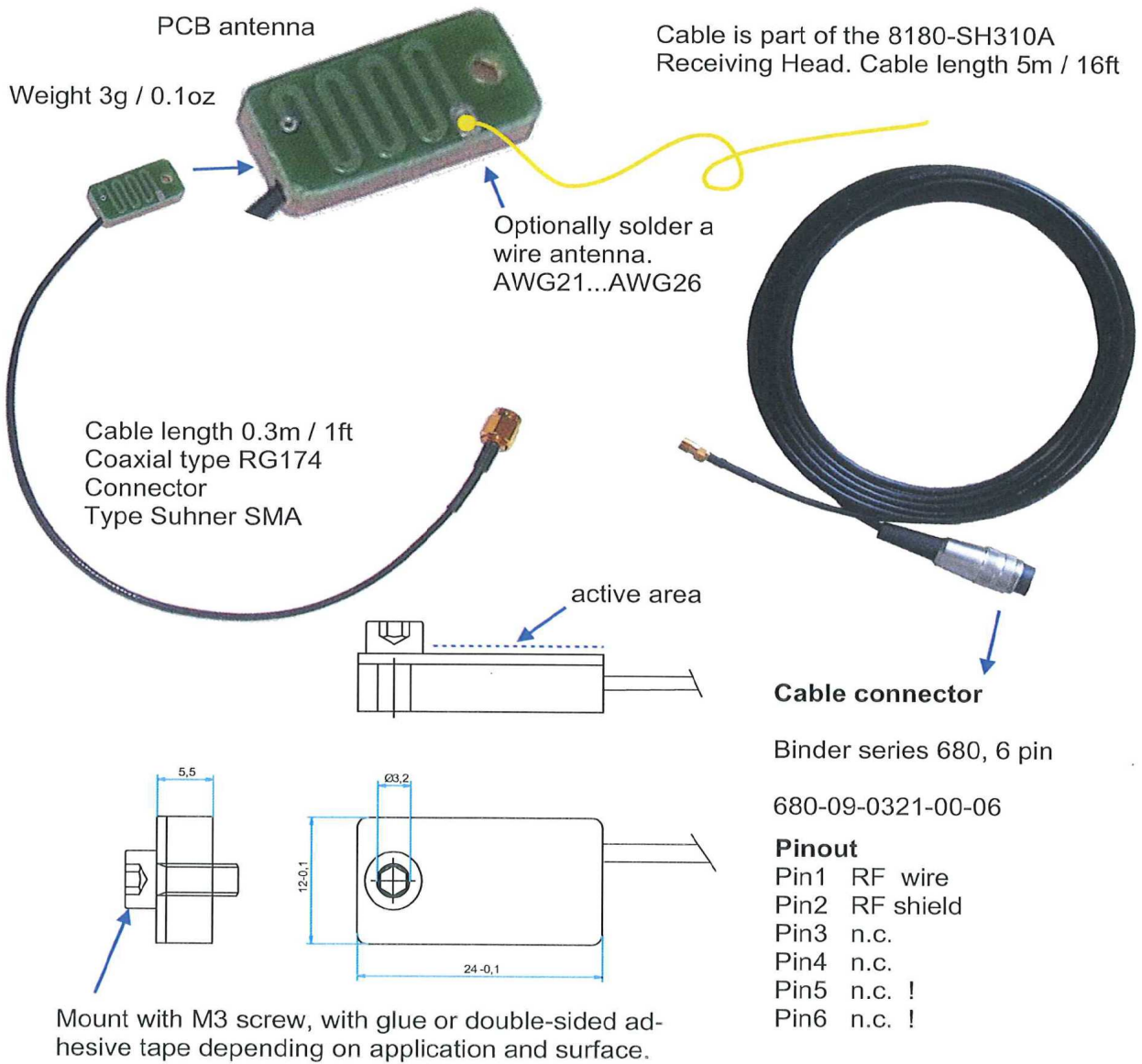

Drawing dimensions in mm

Model 8180

Telemetry cable

The Telemetry cable is supplied of the heads:

- 8180-SH110A
- 8180-SH210A
- 8180-SH410A

with standard length 5m / 16ft.

As an optional accessory the telemetry cable is available in 3 lengths:

- Length 5m / 16ft part **009M192/M05**
- Length 10m / 32ft part **009M192/M010**
- Length 20m / 64ft part **009M192/M020**

Cable connector

LEMO series 0E, 4pin
FFA.0E.304.CLAC50



Pinout

- Pin1 RF wire
- Pin2 RF shield
- Pin3 Power1
- Pin4 Power2

Cable connector

Binder series 680, 6 pin
680-09-0321-00-06

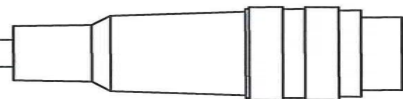

Pinout

- Pin1 RF wire
- Pin2 RF shield
- Pin3 Power1
- Pin4 Power2
- Pin5 Jumpered to turn
- Pin6 power oscillator on

Habia Cable
part-No. 005-10030-010
1xRG 178N + 2xZL 2807 STX



The cable is resistant to most oils, lubricants, water and acids.
The bending radius of the cable should not be less than 1".
Operating temperature range: -40°F to 248°F/ -40° C to 120°C



This cable is specially designed and manufactured for this system. It is extremely robust mechanically, and can be used in extreme environments.
This cable should only be substituted with a direct replacement as a non approved cable will affect the data and tuning of the overall system.



Caution!
Voltage up to 400V_{pp}, 22.5 kHz is on the cable.
Only use the approved original cable.
Damaged or frayed cable must be discarded and replaced immediately.

Model 8180

Control Unit 8180-CU0

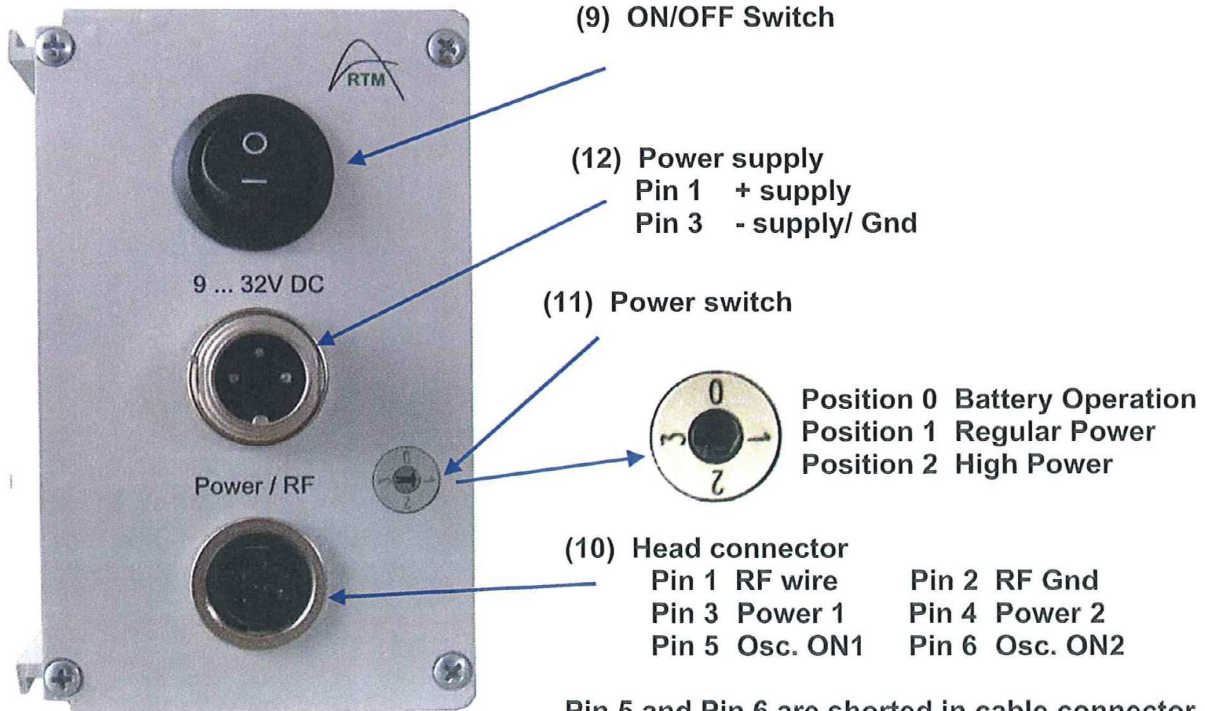
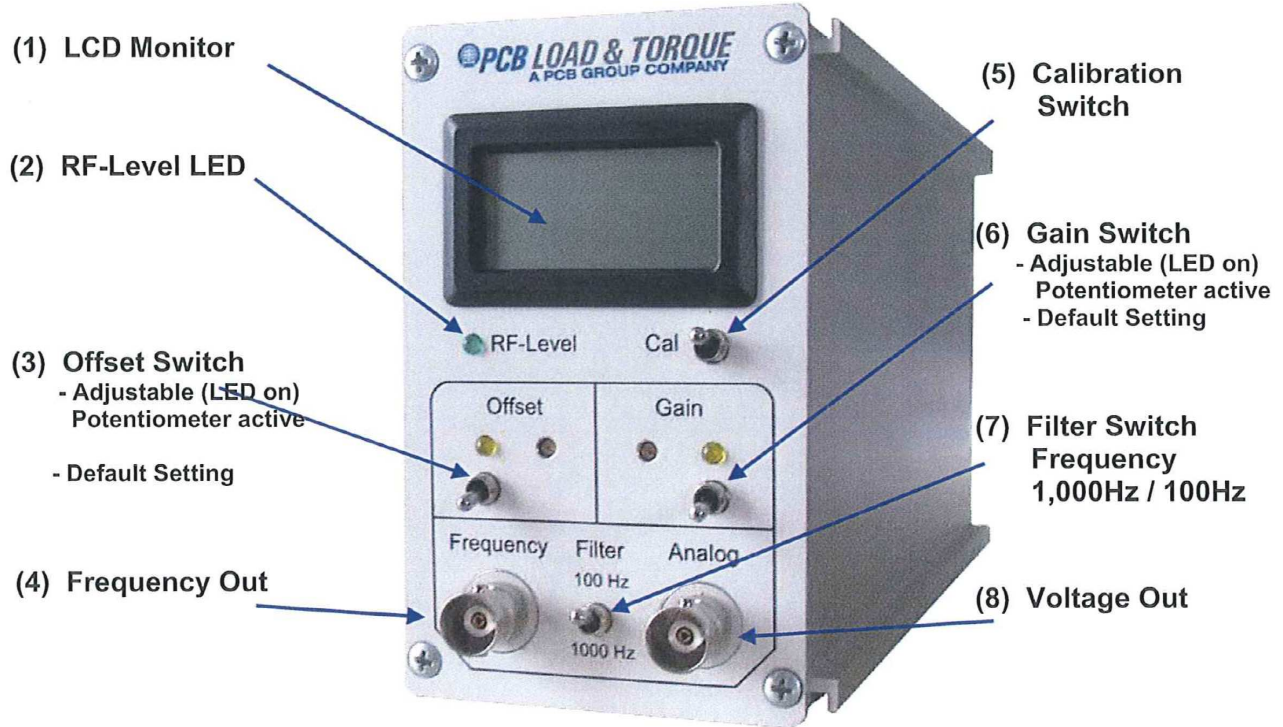

Model 8180

Control unit 8180-CU0

No.	Name	Short description
1	LCD Monitor	3.5 digit display Shows the analog output voltage, $\pm 10V$ Less resolution than analog output
2	RF-Level LED	Lit green LED indicates a good RF level. Data link is good.
3	Offset Switch	Lower position = factory calibration, LED off Upper position = user adjustable, yellow LED on Range $\pm 1.8V$ by potentiometer
4	Frequency Out	Frequency Range is $10kHz \pm 5kHz$ with TTL-level. $10kHz = 0V$; $5kHz = -10V (-FS)$; $15kHz = 10V (+FS)$ BNC Jack
5	Calibration Switch	Initiates a shunt calibration which unbalances the bridge by x% (determined by the user installed shunt resistor)
6	Gain Switch	Lower position = factory calibration, LED off Upper position = user adjustable, yellow LED on Range $\pm 20\%$ by potentiometer
7	Filter Switch	Switches the output filter (4 pole Butterworth) to a 3dB-frequency of 100 Hz or 1 kHz
8	Voltage Out	$-10V \dots 0V \dots +10V$ single ended BNC Jack
9	ON/OFF switch	Rocker switch turns on and off the DC supply voltage to the system.
10	Head connector	Connection for 8180-SHx stators
11	Power switch	Position 0 for use with 8180-SH310A stator head Position 1 Normal setting for all inductive stator heads Position 2 High power for special conditions
12	Power supply connector	DC power input to power Control Unit

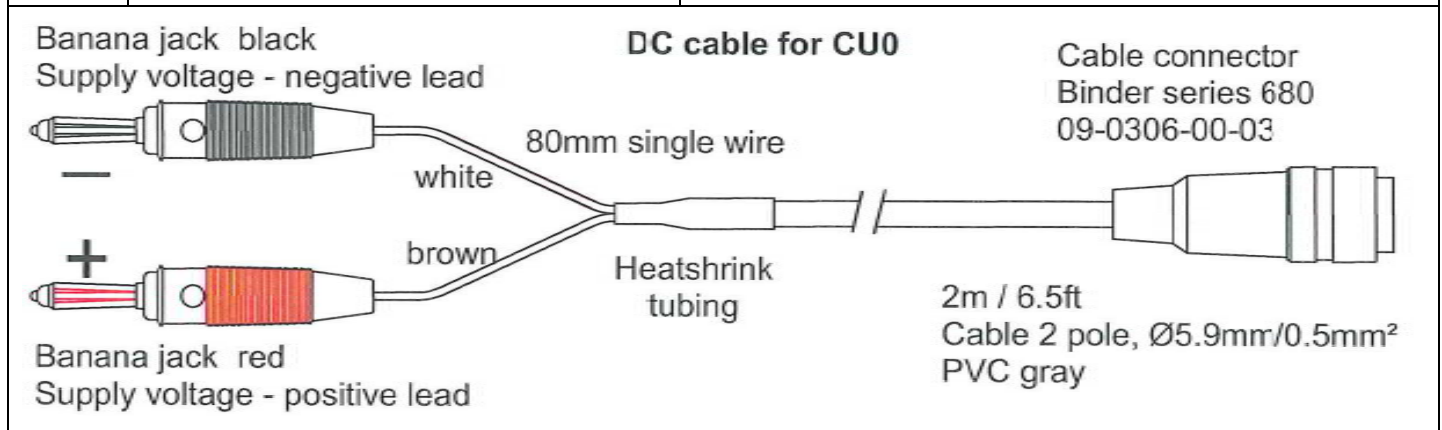

Model 8180

Shunt Calibration

The Shunt-Calibration is an accepted method to system functionality.

A resistor is placed in parallel to leg R in the picture below to unbalance the bridge to predefined value. This predefined value is determined by the value of resistor CAL.

To calculate the resistor CAL value please see chapter "Rotor Electronics 8180-RE1."

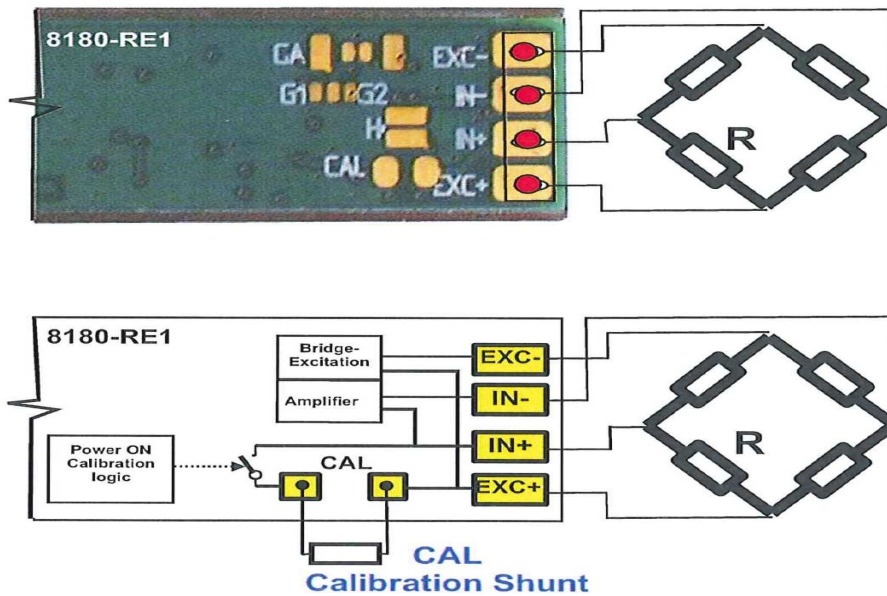

A high quality resistor should be used for the [Shunt](#) resistor and can be of form factors and construction: SMD 1206; 0805; 0603 or wired components.

A shunt calibration is automatically initiated when power is supplied to the system. The shunt is invoked for approximately 2-3 seconds and can be viewed on the Control Unit display and can be measured at the analog and frequency output BNC connectors.

The shunt cal function can be triggered manually by briefly pushing down on the cal switch located on the front panel of the Control Unit. The display and output will show a random value for approximately 8-10 seconds then for another 2-3 seconds the shunt value will be opened and displayed. After which the system returns to normal operation.

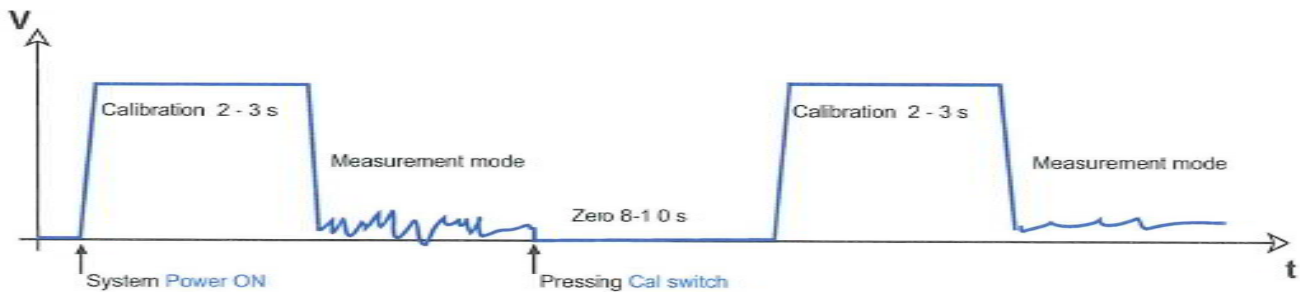

Model 8180

Installation of Antenna

Note: All materials are 1m / 3ft in length and are part of [Installation set 8180-IK00A](#)

The prepared area of the shaft should be wider than the width of the stator head being used
e.g.:

8180-SH1 about 75mm / 2.95"

8180-Sh4 about 30mm / 1.18"

- A** Wrap a layer of insulating tape around the shaft a little wider than the width of the mu metal being used..
- B** Apply a layer of self-adhesive mu-metal. Attention: Gap of 2...6mm!
The ends must not touch.
- C** Completely cover this layer with insulating tape.
- D** Apply another layer of mu-metal. Attention: Gap of 2...6mm!
The gap should be offset by 90 ° ... 180° from the first layer.
- E** Apply over the last layer of mu metal an insulating layer of Kapton tape.
This tape is very temperature-stable and allows soldering of the Copper band antenna.

Note: A third layer of mu metal can improve the ratios and is recommended.

- F** Now apply the Copper band around the shaft dividing the mu metal surface in half.
This Copper band has a self adhesive backing.

Attention: Gap of 1... 3 mm!

- G** Now the wires are soldered to both ends of the Copper band.
- H** The last step is to cover the entire installation with a layer of protective tape.

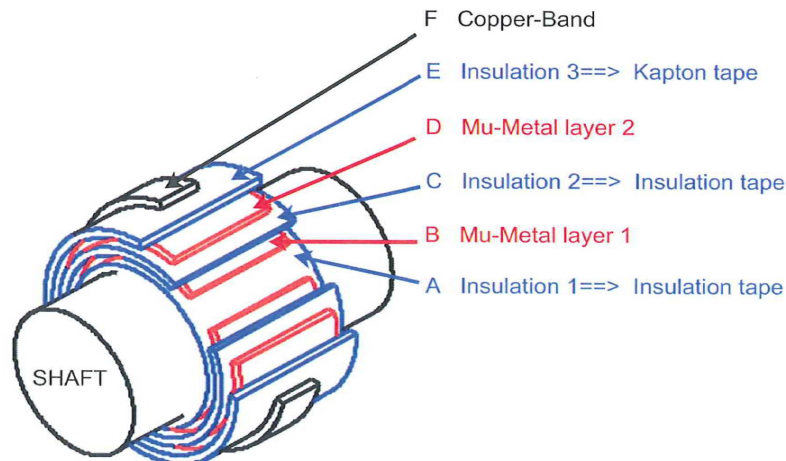

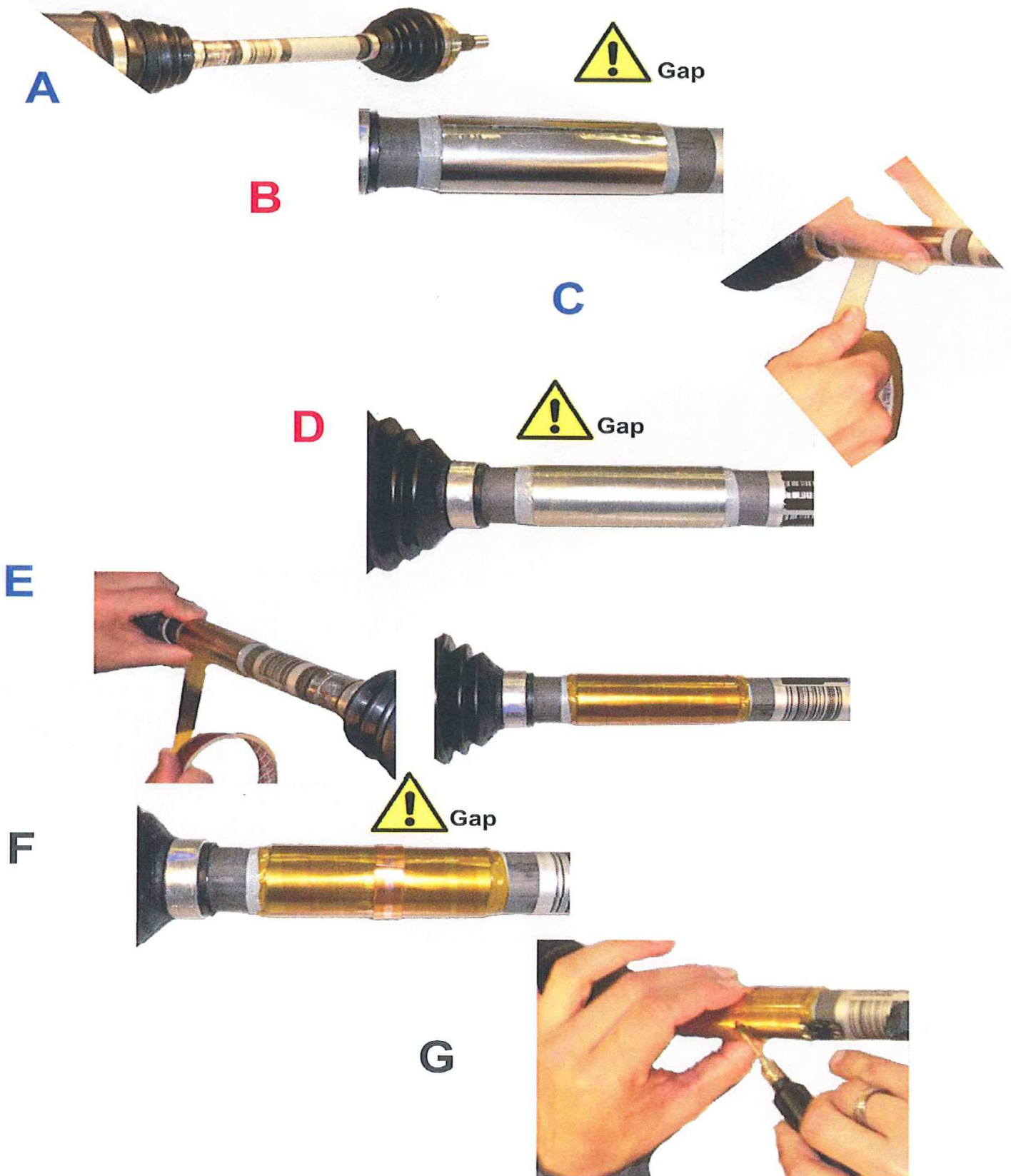

Model 8180

Installation Kit 8180-IK00A

The Installation Kit contains all materials needed for a complete installation on a shaft.

Components

1 m / 3.3ft Copper band, 0.3 mm x 10 xx; self-adhesive backing

2 m / 3.3 ft mu metal, 0.1 mm x 155 mm; self-adhesive

1 roll of insulation tape

1 roll Kapton tape

1 packet 2 components epoxy

0.3 m /1ft wire AWG22 / 0.34 mm²

1 m /3.3ft wire AWG26 / 0.14 mm²



The mu metal can be cut to length using everyday household scissors.

A small amount of 2 part epoxy is typically enough to bond the rotor to the shaft.

Note: It is recommended a layer of nylon reinforced tape be used to strap the rotor electronics in place addition to the 2 part epoxy.



It is the responsibility of the user to ensure the rotor electronics is properly installed on the shaft.

Enough 2 part epoxy should be used to create a saddle to hold the rotor electronics onto the shaft.

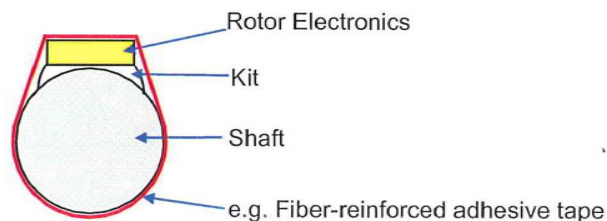

In the interest of constant product improvement, we reserve the right to change specifications without notice

Model 8180

Rainer Thomas Messtechnik GmbH
Ludwig-Erhard-Platz 2
D-83703 Gmund am Tegernsee

Germany

EC – Certificate of Conformity

We hereby certify, that the model of the subsequently designated device corresponds to the essential relevant EC-guidelines mentioned below during compatibility evaluation of the product.

Any changes not agreed with us, will void this declaration.

Description: **1-channel-Telemetry**

Type: **8179; 8180**

Serial numbers: **0290 to 0999**

Relevant EC-guidelines:

Radio and Spectrum engineering parameters: EN 300 220-3

Electromagnetic Compatibility: EN 301 489-01 and 301 489-03

Electric safety: EN 60 950

The device was tested in a typical situation.

Gmund, Oct. 02th 2010

Rainer Thomas