



Model 2301-110-02A

TORQUE SENSOR

Installation and Operating Manual

**For assistance with the operation of this product,
contact PCB Piezotronics, Inc.**

**Toll-free: 800-828-8840
24-hour SensorLine: 716-684-0001
Fax: 716-684-0987
E-mail: info@pcb.com
Web: www.pcb.com**





Service, Repair, and Return Policies and Instructions
--

The information contained in this document supersedes all similar information that may be found elsewhere in this manual.

Service – Due to the sophisticated nature of the sensors and associated instrumentation provided by PCB Piezotronics, user servicing or repair is not recommended and, if attempted, may void the factory warranty. Routine maintenance, such as the cleaning of electrical connectors, housings, and mounting surfaces with solutions and techniques that will not harm the physical material of construction, is acceptable. Caution should be observed to ensure that liquids are not permitted to migrate into devices that are not hermetically sealed. Such devices should only be wiped with a dampened cloth and never submerged or have liquids poured upon them.

Repair – In the event that equipment becomes damaged or ceases to operate, arrangements should be made to return the equipment to PCB Piezotronics for repair. User servicing or repair is not recommended and, if attempted, may void the factory warranty.

Calibration – Routine calibration of sensors and associated instrumentation is recommended as this helps build confidence in measurement accuracy and acquired data. Equipment calibration cycles are typically established by the users own quality regimen. When in doubt about a calibration cycle, a good “rule of thumb” is to recalibrate on an annual basis. It is

also good practice to recalibrate after exposure to any severe temperature extreme, shock, load, or other environmental influence, or prior to any critical test.

PCB Piezotronics maintains an ISO-9001 certified metrology laboratory and offers calibration services, which are accredited by A2LA to ISO/IEC 17025, with full traceability to SI through N.I.S.T. In addition to the normally supplied calibration, special testing is also available, such as: sensitivity at elevated or cryogenic temperatures, phase response, extended high or low frequency response, extended range, leak testing, hydrostatic pressure testing, and others. For information on standard recalibration services or special testing, contact your local PCB Piezotronics distributor, sales representative, or factory customer service representative.

Returning Equipment – *Following these procedures will ensure that your returned materials are handled in the most expedient manner.* Before returning any equipment to PCB Piezotronics, contact your local distributor, sales representative, or factory customer service representative to obtain a Return **Warranty, Service, Repair, and Return Policies and Instructions** Materials Authorization (RMA) Number. This RMA number should be clearly marked on the outside of all package(s) and on the packing

list(s) accompanying the shipment. A detailed account of the nature of the problem(s) being experienced with the equipment should also be included inside the package(s) containing any returned materials.

A Purchase Order, included with the returned materials, will expedite the turn-around of serviced equipment. It is recommended to include authorization on the Purchase Order for PCB to proceed with any repairs, as long as they do not exceed 50% of the replacement cost of the returned item(s). PCB will provide a price quotation or replacement recommendation for any item whose repair costs would exceed 50% of replacement cost, or any item that is not economically feasible to repair. For routine calibration services, the Purchase Order should include authorization to proceed and return at current pricing, which can be obtained from a factory customer service representative.

Contact Information – International customers should direct all inquiries to their local distributor or sales office. A

complete list of distributors and offices can be found at www.pcb.com. Customers within the United States may contact their local sales representative or a factory customer service representative. A complete list of sales representatives can be found at www.pcb.com. Toll-free telephone numbers for a factory customer service representative, in the division responsible for this product, can be found on the title page at the front of this manual. Our ship to address and general contact numbers are:

PCB Piezotronics, Inc.
3425 Walden Ave.
Depew, NY14043 USA
Toll-free: (800) 828-8840
24-hour SensorLineSM: (716) 684-0001
Website: www.pcb.com
E-mail: info@pcb.com



PCB工业监视和测量设备 - 中国RoHS2公布表
 PCB Industrial Monitoring and Measuring Equipment - China RoHS 2 Disclosure Table

部件名称	有害物质					
	铅 (Pb)	汞 (Hg)	镉 (Cd)	六价铬 (Cr(VI))	多溴联苯 (PBB)	多溴二苯醚 (PBDE)
住房	○	○	○	○	○	○
PCB板	X	○	○	○	○	○
电气连接器	○	○	○	○	○	○
压电晶体	X	○	○	○	○	○
环氧	○	○	○	○	○	○
铁氟龙	○	○	○	○	○	○
电子	○	○	○	○	○	○
厚膜基板	○	○	X	○	○	○
电线	○	○	○	○	○	○
电缆	X	○	○	○	○	○
塑料	○	○	○	○	○	○
焊接	X	○	○	○	○	○
铜合金/黄铜	X	○	○	○	○	○
本表格依据 SJ/T 11364 的规定编制。						
○：表示该有害物质在该部件所有均质材料中的含量均在 GB/T 26572 规定的限量要求以下。						
X：表示该有害物质至少在该部件的某一均质材料中的含量超出 GB/T 26572 规定的限量要求。						
铅是欧洲RoHS指令2011/65/ EU附件三和附件四目前由于允许的豁免。						

CHINA RoHS COMPLIANCE

Component Name	Hazardous Substances					
	Lead (Pb)	Mercury (Hg)	Cadmium (Cd)	Chromium VI Compounds (Cr(VI))	Polybrominated Biphenyls (PBB)	Polybrominated Diphenyl Ethers (PBDE)
Housing	O	O	O	O	O	O
PCB Board	X	O	O	O	O	O
Electrical Connectors	O	O	O	O	O	O
Piezoelectric Crystals	X	O	O	O	O	O
Epoxy	O	O	O	O	O	O
Teflon	O	O	O	O	O	O
Electronics	O	O	O	O	O	O
Thick Film Substrate	O	O	X	O	O	O
Wires	O	O	O	O	O	O
Cables	X	O	O	O	O	O
Plastic	O	O	O	O	O	O
Solder	X	O	O	O	O	O
Copper Alloy/Brass	X	O	O	O	O	O

This table is prepared in accordance with the provisions of SJ/T 11364.

O: Indicates that said hazardous substance contained in all of the homogeneous materials for this part is below the limit requirement of GB/T 26572.

X: Indicates that said hazardous substance contained in at least one of the homogeneous materials for this part is above the limit requirement of GB/T 26572.

Lead is present due to allowed exemption in Annex III or Annex IV of the European RoHS Directive 2011/65/EU.

DOCUMENT NUMBER: 21354

DOCUMENT REVISION: **D**

ECN: 46162

TABLE OF CONTENTS

Section	Page
1.0 Introduction	2
2.0 Safety Information	3
3.0 Mechanical Installation	3
4.0 Electrical Installation	4
5.0 Polarity	4
6.0 Shunt Calibration	4
7.0 Operation	5
8.0 Troubleshooting	6
9.0 Maintenance	6

LIST OF ILLUSTRATIONS

Figure	Page
1. Flange Mount Reaction Torque Sensor	2
2. Wheatstone Bridge Circuit	2
3. Western Regional Strain Gage Committee Wiring Code	2
4. Axis and Sense Nomenclature	3
5. Reaction Torque Sensor Configurations	3
6. Shunt Resistor Locations	4
7. Reaction Torque Sensor System Configurations	5

1.0 INTRODUCTION

Reaction torque sensors manufactured by the Force-Torque Division of PCB are strain gage based measuring instruments suitable for a wide range of torque measurement applications. They are rigid structures with no moving parts and are typically mounted in a fixed position. Their output signal varies proportionally to an applied torsional force. Capacities range from 5 to 500k in-lb (0.56 to 56.5k N-m).

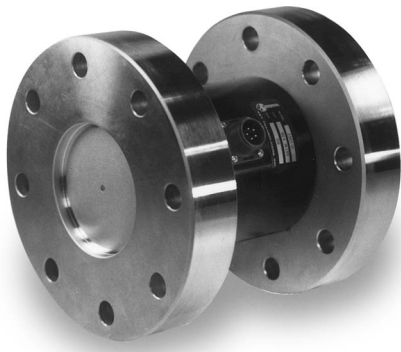

Figure 1 – Flange Mount Reaction Torque Sensor

Due to the fact that these sensors do not utilize bearings, slip rings, or any other rotating elements, their installation and use can be very cost effective. Reaction torque sensors are particularly useful in applications where the introduction of a rotating mass between the driver and driven is undesirable.

All models utilize strain gages configured into a Wheatstone Bridge Circuit to produce the primary sensing element. The four-arm Wheatstone Bridge configuration is shown below in **Figure 2**.

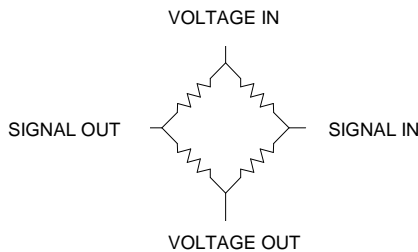

Figure 2 - Wheatstone Bridge Circuit

Most PCB reaction torque sensors follow a wiring code established by the Western Regional Strain

Gage Committee as revised in May 1960. The wiring code is as follows:

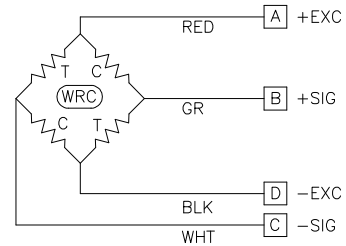

Figure 3 - Western Regional Strain Gage Committee Wiring Code

Refer to the wiring drawing included with this manual for specific wiring of the supplied torque sensor.

The gages are bonded to the sensor’s structure. Typically, a regulated DC or AC excitation is applied between A and D of the bridge. When torque is applied to the sensor, the Wheatstone Bridge becomes unbalanced, causing an output voltage between B and C which is proportional to the applied torque. The magnitude of the output voltage corresponds to the torsional deflection of the sensor structure and therefore the applied torque. This configuration allows for temperature and pressure compensation, as well as cancellation of signals caused by forces not directly applied to the axis of the applied load. Output is typically expressed in units of millivolt per volt of excitation.

Optional signal conditioners are available from PCB. A signal conditioner may have analog voltage output, current output, or digital output. Digital display signal conditioners are also available.

Axis Definition

PCB force products comply with the Axis and Sense Definitions of NAS-938 (National Aerospace Standard-Machine Axis and Motion) nomenclature and recommendations of the Western Regional Strain Gage committee. These axes are defined in terms of a "Right Handed" orthogonal coordinate system as show below. A (+) sign indicates force in a direction which produces a (+) signal voltage and generally defines a clockwise torque.

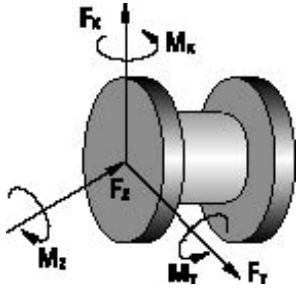

Figure 4 - Axis and Sense Nomenclature for PCB Reaction Torque Sensors

The principal axis of a transducer is normally the M_z axis. The M_z axis will also be the axis of radial symmetry or axis of rotation. In the event there is no clearly defined axis, the following preference system will be used z,x,y.

2.0 SAFETY INFORMATION

Failure of the sensor structure or fasteners used in its installation may cause personal injury and equipment damage. To prevent structure failure, review the extraneous load limits listed on the specification sheet supplied with this manual. Extraneous load limits are extraneous side force,

thrust and bending moment that may be applied without electrical or mechanical damage to the torque sensor. Do not exceed moment ($W \times S$) or shear (W) whichever attained first. Measurement inaccuracy and structure damage may result. Install the sensor in a manner that minimizes these loads. In addition, review data from manufacturers of fixtures and fasteners used in the sensors installation to determine if failure might occur due to these loads.

3.0 MECHANICAL INSTALLATION

Refer to the outline drawing supplied with this manual for specific outline dimensions and installation details for your particular model. The specification is also included to provide details of the sensor's characteristic properties.

Shown below are some of the standard reaction torque sensor configurations offered by the Force/Torque Division.

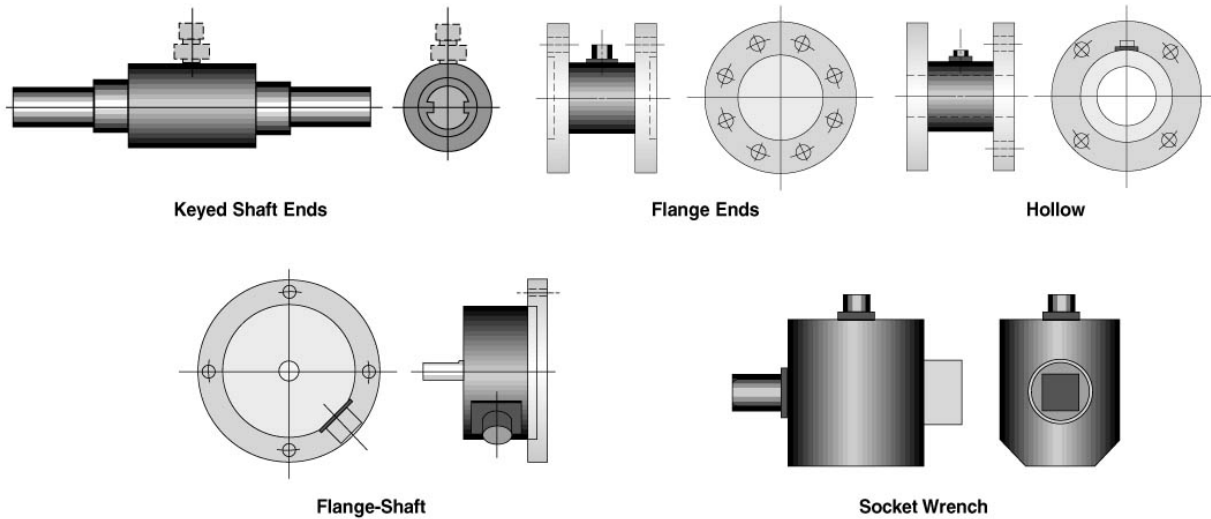

Figure 5 – Reaction Torque Sensor Configurations

4.0 ELECTRICAL INSTALLATION

For proper electrical connections, refer to the installation drawing for the torque sensor, and the wiring drawing for the signal conditioner used. Construct the interconnect cable from high-quality shielded instrumentation cable. Various cable assemblies are available through PCB.

Connect one end of the cable to the sensor connector and the other end to the signal conditioner. Make sure to tighten the cable connector to the sensor. For installation in dirty, humid, or rugged environments, it is suggested that the connection be shielded against dust or moisture with shrink tubing or other protective material. Strain relieving the cable/sensor connection can also prolong cable life. Mounting cables to a test structure with tape, clamps, or adhesives minimizes cable whip.

5.0 POLARITY

Clockwise torque upon standard PCB reaction torque sensors produces a positive-going voltage output. Counter-clockwise torque produces a negative-going voltage output.

6.0 SHUNT CALIBRATION

Shunt calibration is the known, electrical, unbalancing of a strain gage bridge by means of a fixed resistor that is placed, or “shunted”, across one leg of the bridge. The “Wheatstone Bridge” utilized by PCB reaction torque sensors are typically calibrated using the shunt calibration technique.

Shunt calibration is a method of periodically checking the gain or span of a signal conditioner, which is used in conjunction with a strain gage based transducer, without exposing the transducer to known, traceable, physical input values. If required, adjustments can then be made to the signal conditioner to insure accurate measurement results.

The strain gage bridge is “in balance” when the host mechanical structure is unloaded and unstressed.

As the host structure (diaphragm, bending beam, shear beam, column, etc.) is loaded or stressed, the Wheatstone Bridge becomes unbalanced, resulting in an output signal that is proportional to the applied load.

Shunt calibration simulates the mechanical input to a transducer by unbalancing the bridge with a fixed resistor placed across, or in parallel with, one leg of the bridge. For tension shunt calibration, or +CAL, the shunt resistor (R_{st}) is shunted across the +Excitation (A) and +Signal (B) leg of the bridge. For compression shunt calibration, or -CAL, the shunt resistor (R_{sc}) is shunted across the -Excitation (D) and +Signal (B) leg of the bridge. Refer to **Figure 6** for shunt resistor locations in the Wheatstone Bridge circuit.

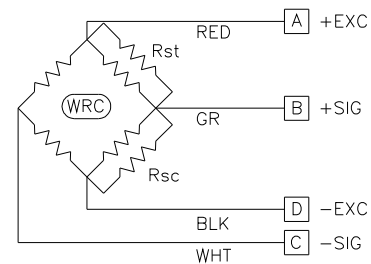

Figure 6 - Shunt Resistor Locations

Shunt Calibration Procedure

1. Connect the transducer to an appropriate strain gage signal conditioner and allow adequate time for the system to stabilize.
2. Apply a full-scale, N.I.S.T. traceable, mechanical input (or torque) to the transducer.
3. Adjust the signal conditioner's gain or span controls, as required, to obtain a full-scale electrical output signal, and/or numeric display that represents the applied, mechanical input quantity.
4. Remove the mechanical input (or torque).
5. Place the shunt calibration resistor across an appropriate leg of the Wheatstone Bridge as discussed above.

6. Record the value of the signal conditioner's output signal and/or numeric display. This value is the shunt calibration value, or equivalent torque.
7. It is important to note that the shunt calibration value is specific for the particular shunt resistor

used. This value, and the particular resistor, are now matched to the transducer and form a basis of the transferable shunt calibration.

Recalculating Shunt Calibration Value

The shunt calibration resistor value and the resulting transducer output can be recalculated using the following formula:

$$\frac{\text{Supplied Transducer Output}}{\text{New Transducer Output}} = \frac{\text{New Resistor Value}}{\text{Supplied Resistor Value}}$$

Shunt calibration is accepted throughout the industry as a means of periodic calibration of a signal conditioner and transducer between calibrations of known, applied, traceable, mechanical, input values. Consequently, most all strain gage transducer manufacturers collect and supply shunt calibration data, along with a shunt calibration resistor, as a standard feature.

7.0 OPERATION

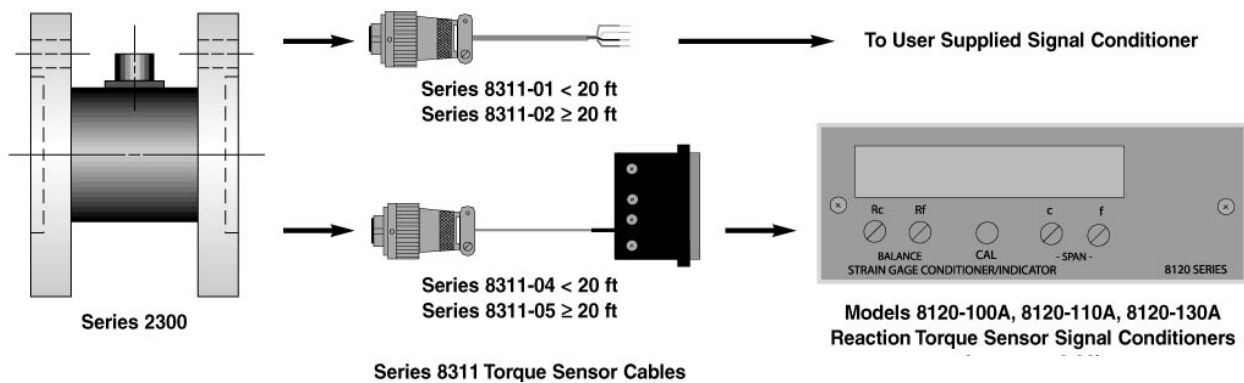

Figure 7 – Reaction Torque Sensor System Configurations

Typical Reaction Torque Sensor System Configurations

Operation requires the connection of the sensor to a signal conditioner, then to a readout device (if signal conditioner does not have a display). Strain gage signal conditioners and cable assemblies are available from PCB.

Operation with a Signal Conditioner

The signal conditioner span and zero must be set before the torque sensor system can be used. The span can be set using dead weights or the shunt calibration value. Refer to the shunt calibration information in this manual, and the signal conditioner instruction manual, for proper set-up information.

8.0 TROUBLESHOOTING

No output

- ✓No power
- ✓Loose or dirty connections
- ✓Circuit opens or shorts
- ✓Faulty or improper wiring
- ✓No load applied

Erratic or Improper Readings

- ✓Excitation voltage drift
- ✓Electrical noise
- ✓Loose fixturing
- ✓Circuit opens or shorts
- ✓Improper torque applied
- ✓Cable too long

Blinking Display

- ✓Overload condition
- ✓Open circuit

Zero Balance

- ✓Torque applied to sensor
- ✓Overloaded or side-loaded sensor
- ✓Open circuit
- ✓Improper electrical connections

Zero Shift

- ✓Fixture preload
- ✓Faulty or improper wiring
- ✓Improper tare

Zero Drift

- ✓Unconditioned power supply
- ✓Circuit opens or shorts
- ✓Loose wiring
- ✓RFI/EMI interface
- ✓Temperature change

Damaged or Deformed Equipment

- ✓Improper use

Often overlooked by the customer, is the error due to the presence of non-measured forces and bending moments. Even Though the Single Axis of

Measurement sensors are designed and built to withstand these non-measured forces and bending moments (extraneous loads), the errors due to them are present. PCB engineers can design the set-up to eliminate or minimize these extraneous loads. However, if these extraneous loads are present, the errors due to them should be considered. Due to cost restraints, the Force/Torque Division, as with its competition, does not typically measure or compensate for errors due to extraneous loads. If the presences of these extraneous loads are known, the user should request the transducer manufacturer to run a special test, at extra cost, to define and quantify the extraneous load errors. These errors are defined as cross-talk errors.

Error Analysis

The Force/Torque Division typically supplies accuracy information on its products in the form of individual errors (see specification sheet). They are: Non-Linearity, Hysteresis, Non-Repeatability, Effect of Temperature on Zero, and Effect of Temperature on Output.

The customer can combine these individual errors to establish the maximum possible error for the measurement or just examine the applicable individual error. If the temperature remains stable during the test, temperature related errors may be ignored. If the sensor is used for increasing load measurement only, ignore the Hysteresis error. If the load measurement is near the full capacity, the linearity error can be ignored. If the capability exists to correct the data through linearization-fit or a look-up-table, the error in the measurement can be minimized. A sophisticated user can get rid of all the errors except for the non-repeatability error in the measurement.

9.0 MAINTENANCE

Routine maintenance, such as cleaning of electrical connectors, housings, and mounting surfaces with solutions and techniques that will not harm the physical material of construction is acceptable.

Caution should be observed to insure that liquids are not permitted to migrate into devices that are not hermetically sealed. Such devices should only be wiped with a damp cloth and never submerged or have liquids poured on them.

Model Number 2301-110-02A	REACTION TORQUE SENSOR	Revision: B ECN #: 44666
------------------------------	-------------------------------	-----------------------------

	ENGLISH	SI	
Performance			
Measurement Range	5000 lbf-in	565 Nm	
Sensitivity(± 10 %)	2 mV/V	2 mV/V	[5][4]
Non-Linearity	≤ 0.10 % FS	≤ 0.10 % FS	[4]
Hysteresis	≤ 0.10 % FS	≤ 0.10 % FS	[4]
Non-Repeatability	≤ 0.02 % FS	≤ 0.02 % FS	[4]
Resonant Frequency	1.8 kHz	1.8 kHz	
Maximum Torque	7500 lbf-in	847 Nm	
Environmental			
Overload Limit(Axial Thrust)	5000 lbf	22.2 kN	[2]
Overload Limit(Overhung Moment)	2500 lbf-in	282 Nm	[2]
Overload Limit(Shear)	2500 lbf	11.1 kN	[2]
Temperature Range(Operating)	-65 to +200 °F	-54 to +93 °C	
Temperature Range(Compensated)	+70 to +170 °F	+21 to +77 °C	
Temperature Effect on Output(Maximum)	± 0.002 %Reading/°F	± 0.0036 %Reading/°C	[3]
Temperature Effect on Zero Balance(Maximum)	± 0.002 %FS/°F	± 0.0036 %FS/°C	[4][3]
Electrical			
Bridge Resistance	350 Ohm	350 Ohm	
Excitation Voltage(Recommended)	10 VDC	10 VDC	[1]
Insulation Resistance	>5 GOhm	>5 GOhm	
Zero Balance	≤ 1 %RO	≤ 1 %RO	
Output Polarity	cw+	cw+	
Physical			
Size (Diameter x Length)	4.00 in x 3.00 in	101.6 mm x 76.2 mm	[6]
Weight	5 lb	2.268 kg	
Mounting	Flange (5/16in Bolts)	Flange (M8 Bolts)	
Torsional Stiffness	1400 klf-in/radian	158 kN-m/radian	
Sensing Element	Strain Gage	Strain Gage	
Housing Material	Anodized Aluminum	Anodized Aluminum	
Electrical Connector	MS3102E-14S-6P	MS3102E-14S-6P	
Sensor Material	plated steel	plated steel	

OPTIONAL VERSIONS

Optional versions have identical specifications and accessories as listed for the standard model except where noted below. More than one option may be used.

NOTES:

[1] Calibrated at 10 VDC, usable 5 to 20 VDC or VAC RMS.
 [2] Singularity applied, i.e. no other extraneous loads.
 [3] Over compensated operating temperature range.
 [4] FS - Full Scale.
 [5] Nominal.
 [6] See outline drawing 26444 for complete dimensions

OPTIONAL ACCESSORIES:
 Model 180-012A Mating connector (1)

Entered: LK	Engineer: JSD	Sales: RB	Approved: JM	Spec Number:
Date: 12/30/2015	Date: 12/30/2015	Date: 12/30/2015	Date: 12/30/2015	23541



All specifications are at room temperature unless otherwise specified.
 In the interest of constant product improvement, we reserve the right to change specifications without notice.

26444

PCB Load & Torque (A Division of PCB Piezotronics, Inc.)
claims proprietary rights in the information disclosed hereon.
Neither it nor any reproduction thereof will be disclosed to
others without the written consent of PCB Load and Torque.

REVISIONS		
REV	DESCRIPTION	ECO
A	CORRECTED CONN. VIEW - 02.22.18, PTE	47634

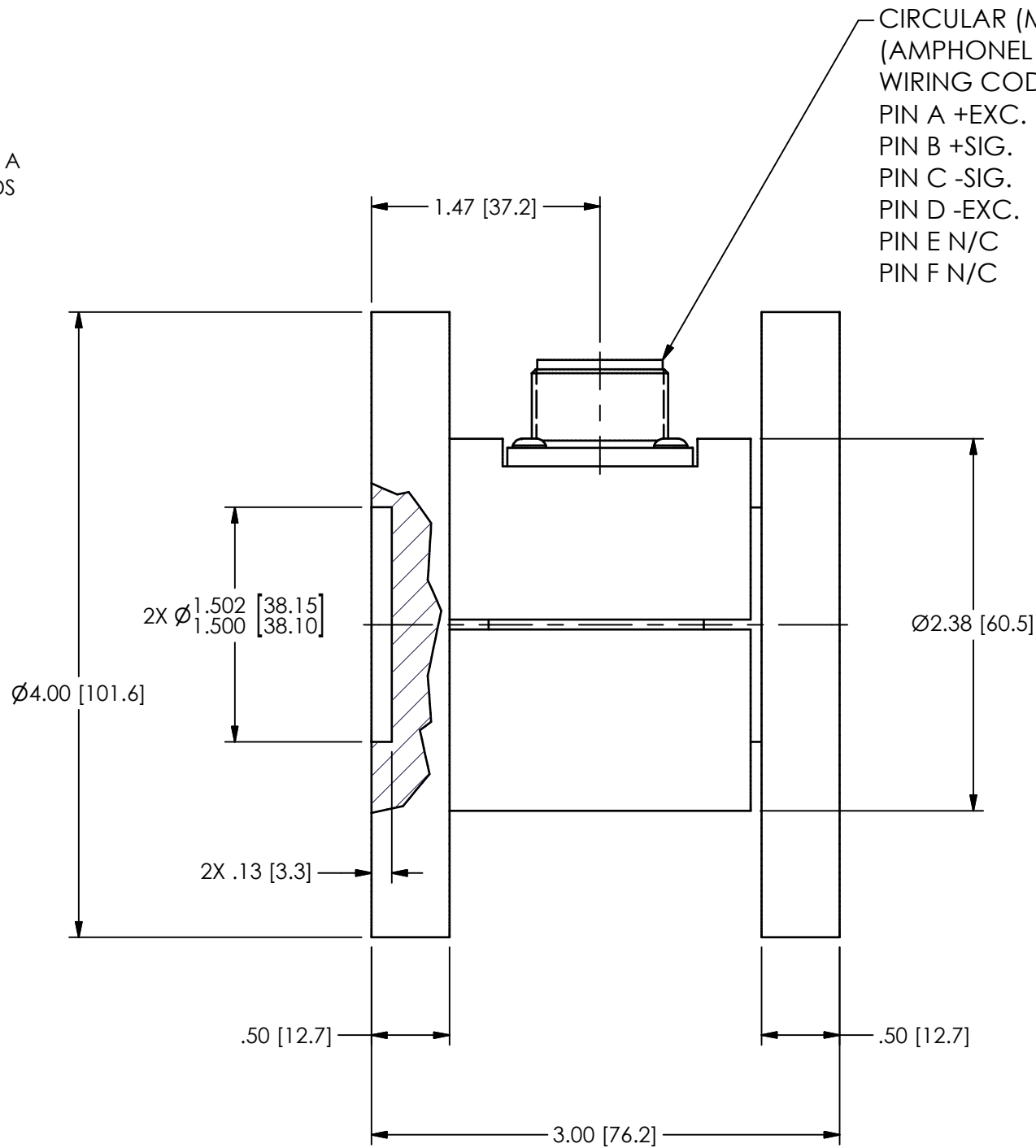
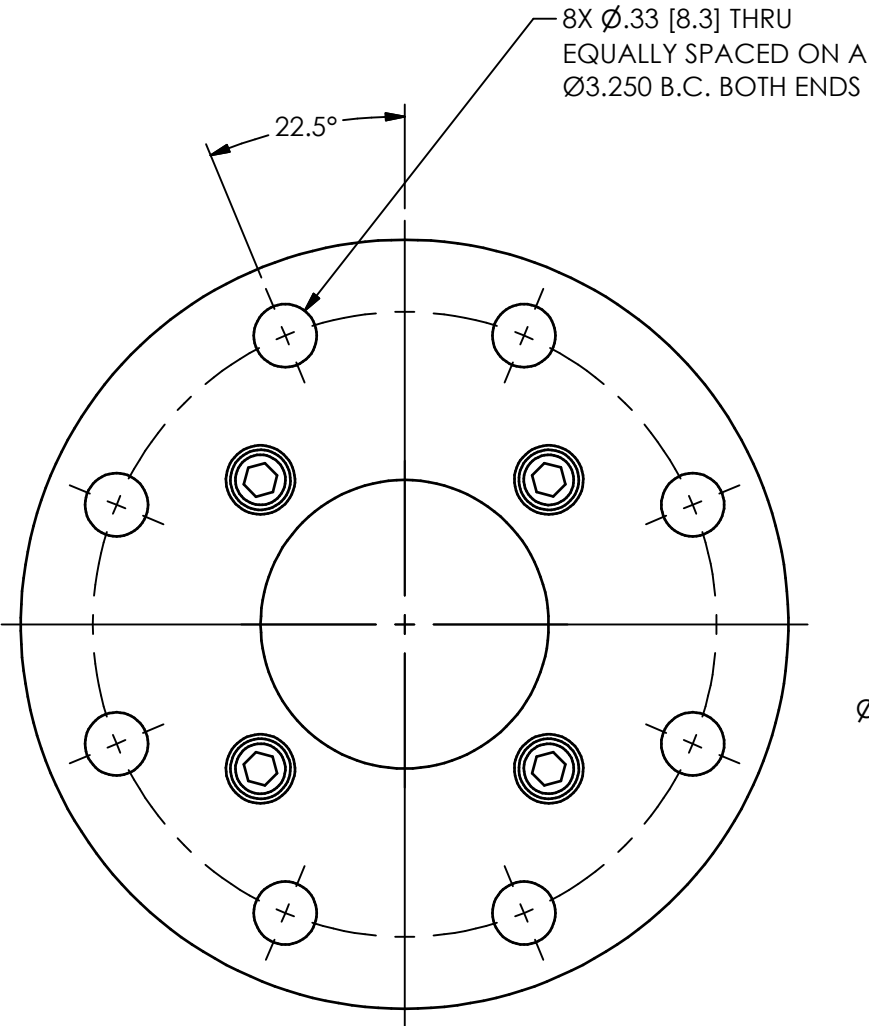

CIRCULAR (MIL SPEC.) RECEPTACLE
(AMPHONEL MS3102E-14S-6P OR EQUIV.)
WIRING CODE (WR):
PIN A +EXC.
PIN B +SIG.
PIN C -SIG.
PIN D -EXC.
PIN E N/C
PIN F N/C

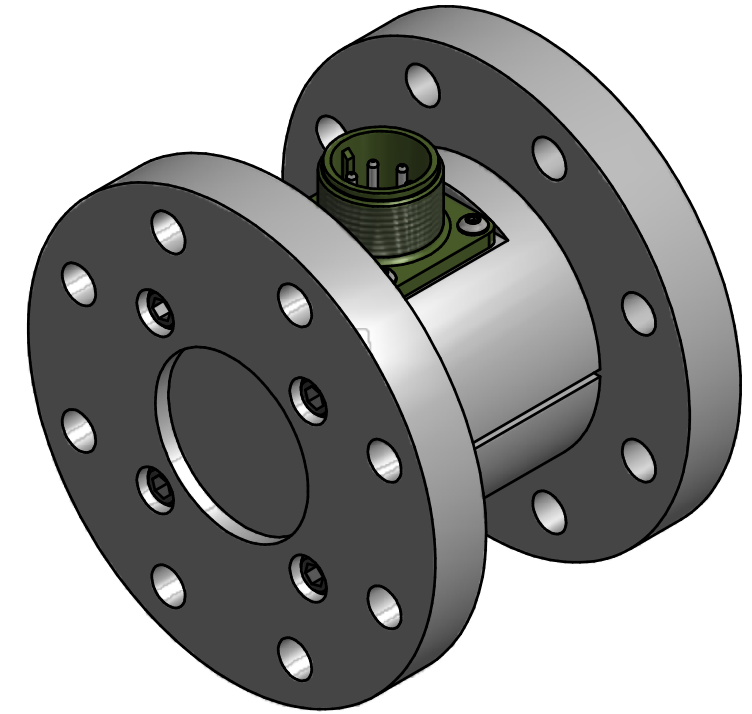

ISO VIEW
SCALE 3 / 4

UNLESS OTHERWISE SPECIFIED TOLERANCES ARE:		DRAWN	CHECKED	ENGINEER	 A PCB GROUP COMPANY
DIMENSIONS IN INCHES	DIMENSIONS IN MILLIMETERS [IN BRACKETS]	DMB 06.03.04	MJK 06.04.04	DMB 06.03.04	
DECIMALS XX ±.01 XXX ±.005	DECIMALS X ±.3 XX ±.13	TITLE OUTLINE DRAWING MODEL 2301-110-XXA SERIES REACTION TORQUE SENSOR			24350 Indoplex Circle, Farmington Hills, MI 48335 (248) 888-8260 E-MAIL: linfo@pcb.com
ANGLES ± .5 DEGREES	ANGLES ± .5 DEGREES				DWG. NO.
FILLETS AND RADII .015 MAX	FILLETS AND RADII 0.38 MAX	SCALE: FULL	SHEET	1 OF 1	