



Model 059740-01185

Fastener Torque-Tension Load Cell, Clamp Load Capacity 1,800 kN

Installation and Operating Manual

**For assistance with the operation of this product,
contact PCB Piezotronics, Inc.**

**Toll-free: 800-828-8840
24-hour SensorLine: 716-684-0001
Fax: 716-684-0987
E-mail: info@pcb.com
Web: www.pcb.com**



Repair and Maintenance

PCB guarantees Total Customer Satisfaction through its “Lifetime Warranty Plus” on all Platinum Stock Products sold by PCB and through its limited warranties on all other PCB Stock, Standard and Special products. Due to the sophisticated nature of our sensors and associated instrumentation, **field servicing and repair is not recommended and, if attempted, will void the factory warranty.**

Beyond routine calibration and battery replacements where applicable, our products require no user maintenance. Clean electrical connectors, housings, and mounting surfaces with solutions and techniques that will not harm the material of construction. Observe caution when using liquids near devices that are not hermetically sealed. Such devices should only be wiped with a dampened cloth—never saturated or submerged.

In the event that equipment becomes damaged or ceases to operate, our Application Engineers are here to support your troubleshooting efforts 24 hours a day, 7 days a week. Call or email with model and serial number as well as a brief description of the problem.

Calibration

Routine calibration of sensors and associated instrumentation is necessary to maintain measurement accuracy. We recommend calibrating on an annual basis, after exposure to any extreme environmental influence, or prior to any critical test.

PCB Piezotronics is an ISO-9001 certified company whose calibration services are accredited by A2LA to ISO/IEC 17025, with full traceability to SI through N.I.S.T. In addition to our standard calibration services, we also offer specialized tests, including: sensitivity at elevated or cryogenic temperatures, phase response, extended high or low frequency response, extended range, leak testing, hydrostatic pressure testing, and others. For more information, contact your local PCB Piezotronics distributor, sales representative, or factory customer service representative.

Returning Equipment

If factory repair is required, our representatives will provide you with a Return Material Authorization (RMA) number, which we use to reference any information you have already provided and expedite the repair process. This number should be clearly marked on the outside of all returned package(s) and on any packing list(s) accompanying the shipment.

Contact Information

PCB Piezotronics, Inc.
3425 Walden Ave.
Depew, NY14043 USA
Toll-free: (800) 828-8840
24-hour SensorLine: (716) 684-0001
General inquiries: info@pcb.com
Repair inquiries: rma@pcb.com

For a complete list of distributors, global offices and sales representatives, visit our website, www.pcb.com.

Safety Considerations

This product is intended for use by qualified personnel who recognize shock hazards and are familiar with the precautions required to avoid injury. While our equipment is designed with user safety in mind, the protection provided by the equipment may be impaired if equipment is used in a manner not specified by this manual.

Discontinue use and contact our 24-Hour Sensorline if:

- Assistance is needed to safely operate equipment
- Damage is visible or suspected
- Equipment fails or malfunctions

For complete equipment ratings, refer to the enclosed specification sheet for your product.

Definition of Terms and Symbols

The following symbols may be used in this manual:



DANGER

Indicates an immediate hazardous situation, which, if not avoided, may result in death or serious injury.

**CAUTION**

Refers to hazards that could damage the instrument.

**NOTE**

Indicates tips, recommendations and important information. The notes simplify processes and contain additional information on particular operating steps.

The following symbols may be found on the equipment described in this manual:



This symbol on the unit indicates that high voltage may be present. Use standard safety precautions to avoid personal contact with this voltage.



This symbol on the unit indicates that the user should refer to the operating instructions located in the manual.



This symbol indicates safety, earth ground.



PCB工业监视和测量设备 - 中国RoHS2公布表

PCB Industrial Monitoring and Measuring Equipment - China RoHS 2 Disclosure Table

部件名称	有害物质					
	铅 (Pb)	汞 (Hg)	镉 (Cd)	六价铬 (Cr(VI))	多溴联苯 (PBB)	多溴二苯醚 (PBDE)
住房	0	0	0	0	0	0
PCB板	X	0	0	0	0	0
电气连接器	0	0	0	0	0	0
压电晶体	X	0	0	0	0	0
环氧	0	0	0	0	0	0
铁氟龙	0	0	0	0	0	0
电子	0	0	0	0	0	0
厚膜基板	0	0	X	0	0	0
电线	0	0	0	0	0	0
电缆	X	0	0	0	0	0
塑料	0	0	0	0	0	0
焊接	X	0	0	0	0	0
铜合金/黄铜	X	0	0	0	0	0
本表格依据 SJ/T 11364 的规定编制。						
0：表示该有害物质在该部件所有均质材料中的含量均在 GB/T 26572 规定的限量要求以下。						
X：表示该有害物质至少在该部件的某一均质材料中的含量超出 GB/T 26572 规定的限量要求。						
铅是欧洲RoHS指令2011/65/ EU附件三和附件四目前由于允许的豁免。						

CHINA RoHS COMPLIANCE

Component Name	Hazardous Substances					
	Lead (Pb)	Mercury (Hg)	Cadmium (Cd)	Chromium VI Compounds (Cr(VI))	Polybrominated Biphenyls (PBB)	Polybrominated Diphenyl Ethers (PBDE)
Housing	O	O	O	O	O	O
PCB Board	X	O	O	O	O	O
Electrical Connectors	O	O	O	O	O	O
Piezoelectric Crystals	X	O	O	O	O	O
Epoxy	O	O	O	O	O	O
Teflon	O	O	O	O	O	O
Electronics	O	O	O	O	O	O
Thick Film Substrate	O	O	X	O	O	O
Wires	O	O	O	O	O	O
Cables	X	O	O	O	O	O
Plastic	O	O	O	O	O	O
Solder	X	O	O	O	O	O
Copper Alloy/Brass	X	O	O	O	O	O

This table is prepared in accordance with the provisions of SJ/T 11364.

O: Indicates that said hazardous substance contained in all of the homogeneous materials for this part is below the limit requirement of GB/T 26572.

X: Indicates that said hazardous substance contained in at least one of the homogeneous materials for this part is above the limit requirement of GB/T 26572.

Lead is present due to allowed exemption in Annex III or Annex IV of the European RoHS Directive 2011/65/EU.

TABLE OF CONTENTS

1.0 INTRODUCTION..... 2

2.0 SAFETY PRECAUTIONS 2

3.0 OVERVIEW 2

 3.1 Dimensions 2

 3.2 Standard Components 3

 3.3 Fixturing 3

 3.4 Data Acquisition and Cables 3

4.0 MECHANICAL INSTALLATION 4

 4.1 Mounting the Load Cell 4

 4.2 Mounting the Load Cell Clamp 4

 4.3 Fixturing Installation 4

5.0 ELECTRICAL INSTALLATION 4

 5.1 Connector Wiring Code 4

 5.2 Output Polarity 5

 5.3 Cable & Grounding Considerations 5

6.0 CALIBRATION..... 5

 6.1 Calibration Certificate Description 5

 6.1.1 Measured Output 5

 6.1.2 Hysteresis 5

 6.1.3 Best Fit Output 5

 6.1.4 Strain Gage Measurements 5

 6.1.5 Shunt Calibration Standard Resistor 6

 6.1.6 Static Error Band (SEB) 6

7.0 CROSS-TALK COMPENSATION..... 6

8.0 SHUNT CALIBRATION DESCRIPTION 6

 8.1 Resistor Value 6

 8.2 Shunt Calibration Process 6

 8.3 Estimating Shunt Resistor for a Given Load 6

9.0 MAINTENANCE 6

10.0 TROUBLESHOOTING 6

 10.1 Mechanical Troubleshooting 6

 10.2 Electrical Troubleshooting 7

11.0 CALIBRATION / REPAIR SERVICES 7

 11.1 RMA / Purchase Order 7

12.0 WARRANTY 7

1.0 INTRODUCTION

Fastener torque-tension load cells manufactured by PCB Load & Torque are designed to accurately measure tensile loads and thread torque on threaded fasteners.

Input Torque: Torque applied to the fastener (either to the bolt head or nut).

Bolt Tension: Bolt preload caused by the bolt stretching.

Thread Torque: Reaction torque to the installation torque less the torque to overcome friction in the bearing region.

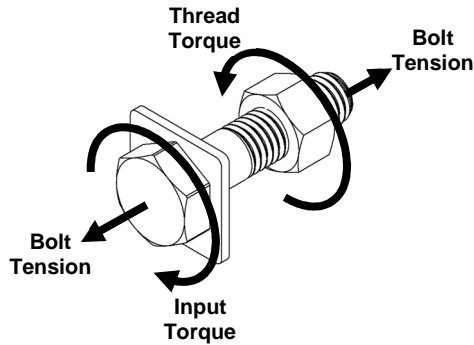

Figure 1 - Bolt Loads

These measurements, along with the input torque, allow for the calculation of the friction coefficients in the tested bolt assembly.

The fastener torque-tension load cells minimize the effects the tensile load has on the thread torque through cross-talk compensation methods. This increases the accuracy of the thread torque measurements, which in turn creates a more accurate friction calculation.

The following document explains the use and fixturing of the load cell for the testing of threaded fasteners.

2.0 SAFETY PRECAUTIONS

Failure of the load cell structure or fasteners being tested in the load cell may cause personal injury and equipment damage.

The load cell can withstand loads of at least 150% of the full-scale capacity before any damage occurs to the sensing element. Be sure that the load cell and any fixturing used is properly and securely installed prior to use.

Fasteners tested to failure resulting in the fastener breaking may act like a projectile at the point of failure. When performing this type of testing be sure that proper safe guards and shielding are in place to prevent any personal injury or equipment damage.

3.0 OVERVIEW

Fastener torque-tension load cells come in a wide range of capacities to handle bolt diameters ranging from #4 (3mm) to 2½ inches (64mm).

Table 1 - Full-Scale Capacities

Model	Full-Scale Capacities					
	Tension		Thread Torque		Recommended Bolt Range	
	(lbf)	(N)	(lbf-ft)	(N-m)	Minimum	Maximum
059400-01024	4,496	20k	15	20	#4 (M3)	#12 (M6)
059500-01044	8,992	40k	44	60	1/4" (M6)	5/16" (M8)
059600-01104	22k	100k	111	150	5/16" (M8)	9/16" (M14)
059625-01304	85k	300k	590	800	9/16" (M14)	7/8" (M22)
059650-01604	135k	600k	1,475	2,000	3/4" (M20)	1 1/8" (M30)
059720-01095	200k	900k	2,950	4,000	1" (M24)	1 1/2" (M39)
059740-01185	405k	1,800k	5,901	8,000	1 3/4" (M33)	2 1/2" (M64)

3.1 Dimensions

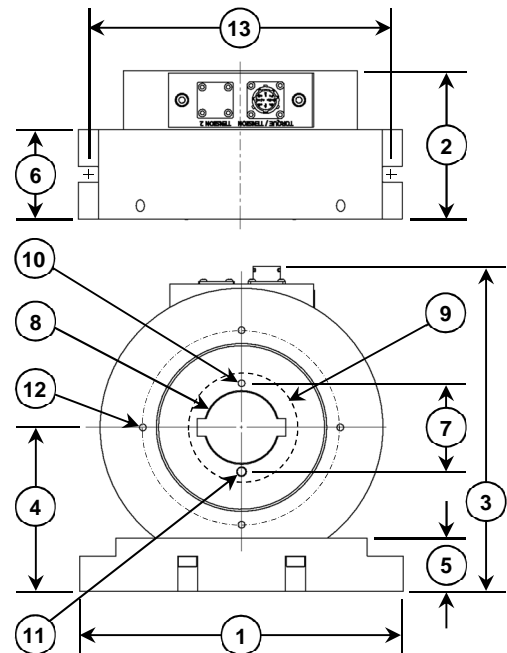

Figure 2 - Dimensions

Table 2 - Dimension Values

Dimensions (see Figure 2)	Model Number			
	059400-01024 059500-01044 059600-01104 059625-01304 059650-01604		059720-01095 059740-01185	
	(in)	(mm)	(in)	(mm)
1	9.00	228.6	14.75	374.7
2	4.13	104.9	6.18	157.0
3	9.56	242.8	15.63	397.0
4	5.00	127.0	8.38	212.9
5	1.50	38.1	2.25	57.2
6	2.50	63.5	4.43	112.5
7	2.50	63.5	3.13	79.5
8	Ø2.03	Ø51.6	Ø2.56	Ø65.0
9	Ø3.06	Ø77.7	Ø5.78	Ø146.8
10	M6x1.0 Tapped Hole		Ø0.375 Dowel Pin	Ø9.53 Dowel Pin
11	Ø0.277 Dowel Pin	Ø7.04 Dowel Pin		
12	M6x1.0 Tapped 4 Places 90° Apart		M8x1.25 Tapped 4 Places 90° Apart	
Thread Depth	0.50		1.00	
Bolt Circle	5.50		7.00	
Mounting				
13	7.00		14.75	
Screw Ø	3/8		5/8	
	M10		M16	

3.2 Standard Components

The following figure describes the standard components of the fastener torque-tension load cells.

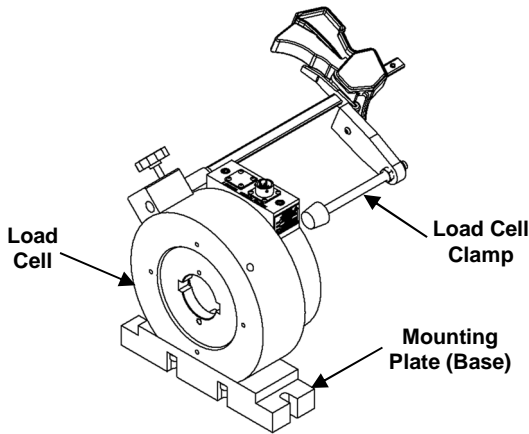

Figure 3 - Standard Components

3.3 Fixturing

Fixturing is necessary for testing of threaded fasteners in the torque-tension load cell. A bushing and plate are required as shown in the following figure.

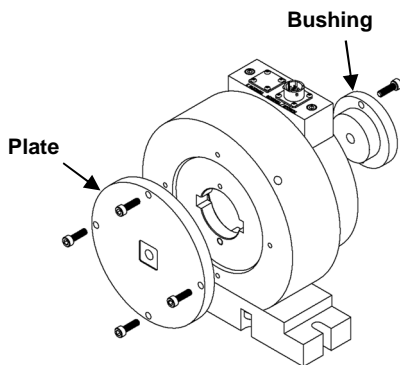

Figure 4 - Fixturing

Each fastener diameter size requires it's own fixturing set. The following table lists the standard fixturing sets available.

NOTE: The fixturing sets listed are not designed to accommodate all fasteners. As fasteners can vary in length and specification so does the fixturing required to accommodate them. Be sure to have the fastener dimensions ready when ordering.

NOTE: The fixturing sets listed are standard Skidmore-Wilhelm Model J, modified to fit the torque-tension load cells.

Table 3 - Fixturing Sets

Item Number	Size	Item Number	Size
100008-02000	#8	1000M6-30429	6 mm
100010-02000	#10	1000M8-30430	8 mm
100250-02000	1/4 inch	100M10-30431	10 mm
100313-02000	5/16 inch	100M12-30432	12 mm
100375-02000	3/8 inch	100M14-30433	14 mm
100438-02000	7/16 inch	100M16-30434	16 mm
100500-02000	1/2 inch	100M18-30435	18 mm
100563-02000	9/16 inch	100M20-30436	20 mm
100625-02000	5/8 inch	100M22-30438	22 mm
100750-02000	3/4 inch	100M25-30437	25 mm
100875-02000	7/8 inch	100M27-30440	27 mm
101000-02000	1 inch	100M30-30443	30 mm
101125-02000	1 1/8 inch		
101250-02000	1 1/4 inch		
101500-02000	1 1/2 inch		

Note: The fixturing listed in Table 3 are based off of standard test plate thicknesses. These will not work with all bolt lengths. Special fixturing or multiple plates may have to be used to accommodate longer bolt lengths. A proper stack-up length will leave at least 2 threads protruding from the nut when fully tightened as shown in Figure 5.

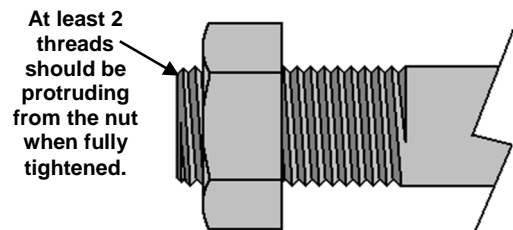

Figure 5 – Proper Thread Engagement

3.4 Data Acquisition and Cables

For friction calculations, the fastener torque-tension load cell requires a data acquisition system with a minimum of three channels (one each for input torque, tension, and thread torque). The following table describes compatible data acquisition systems and cables manufactured by PCB Load & Torque.

Table 4 – Data Acquisition Systems and Cables

Item Number	Description
083210-01000	Model 3210 LabMaster Portable
093210-49586	Cable – Torque-Tension Load Cell to Model 3210 – 10 feet
083200-01000	Model 3200 LabMaster Professional
099404-30566	Cable – Torque-Tension Load Cell to Model 3200 – 10 feet

4.0 MECHANICAL INSTALLATION

The following sections describe the mechanical installation of mounting the load cell, mounting the load cell clamp, and installation of the fixturing to perform a test.

4.1 Mounting the Load Cell

All fastener torque-tension load cells come with a supplied factory installed mounting plate to allow for mounting on a test stand or bench. Depending on the load cell there are 2 to 6 mounting slots (see Figure 2 and Table 2 for mounting dimensions and screws).

4.2 Mounting the Load Cell Clamp

All fastener torque-tension load cells come supplied with a load cell clamp designed to hold the bolt in place while tightening the nut. The clamp is mainly used for locknut testing and is not required for all testing. To attach, simply tighten the supplied M10x1.5 socket head cap screw through the hole in the clamps mounting base into one of the tapped holes on the top of the black ring of the load cell (see Figures 3 and 6).

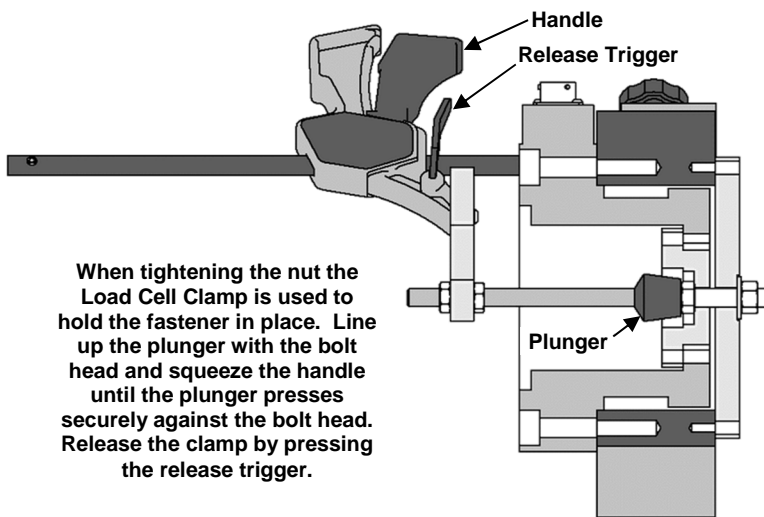

When tightening the nut the Load Cell Clamp is used to hold the fastener in place. Line up the plunger with the bolt head and squeeze the handle until the plunger presses securely against the bolt head. Release the clamp by pressing the release trigger.

Figure 6 – Load Cell Clamp Installation

4.3 Fixturing Installation

Load cell fixturing sets are comprised of a plate and a bushing of a particular fastener diameter size (see Figure 4). The plate mounts to the black ring of the load cell with four screws (screw size depends on size of the load cell, see Figure 2 and Table 2). The bushing mounts on the inside of the load cell. The bushing should line up with the pins in the load cell and held in place with a screw. Figure 7 describes how the fixturing is mounted to the load cell.

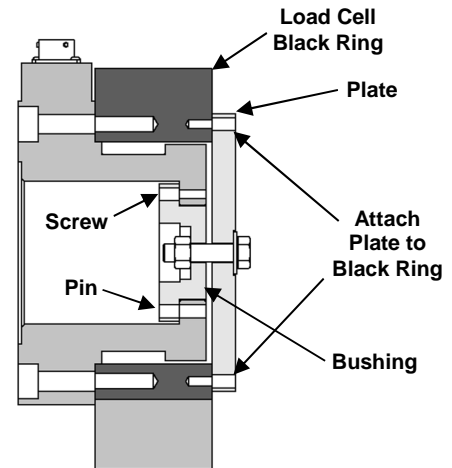

Figure 7 - Fixturing Installation

NOTE: It is important that the screw for the bushing is used to ensure that the bushing is securely installed and perpendicular to loading. If the bushing is not in flush, data values can be skewed and damage to the load cell can occur.

5.0 ELECTRICAL INSTALLATION

Table 5 – Electrical Connections

Load Cell Receptacle:	PT02H-12-10P
PCB Load & Torque P/N:	42410-000755
Mating Connector:	PT02A-12-10S(SR)
PCB Load & Torque P/N:	4242R-000630

5.1 Connector Wiring Code

All load cells are wired following the standard.

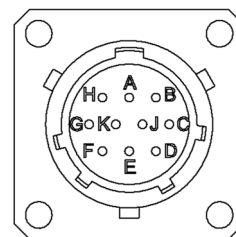

- Tension**
- A + Excitation
- B - Excitation
- C + Signal
- D - Signal
- H + Sense (A-H Jumper)
- K - Sense (B-K Jumper)
- Torque**
- E + Excitation
- F - Excitation
- G + Signal
- J - Signal

Figure 8 - Connector Wiring Code

5.2 Output Polarity

The following figure describes the positive output polarity.

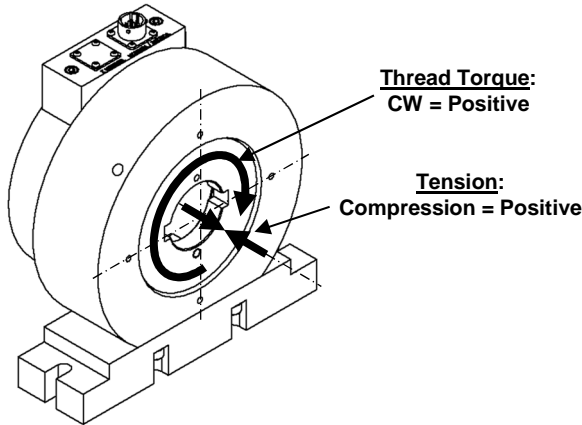

Figure 9 - Output Polarity

5.3 Cable & Grounding Considerations

Proper grounding and shielding is required to prevent electrical noise in strain gage load cell measuring systems. The cable must be shielded twisted pairs with a drain wire.

Cable shields must be grounded only at one end, for example, on the instrument or control system ground. The load cell case is grounded by mechanical attachment to the structure to which it is mounted.

The instrument or control system is grounded through its power cord. Ground loops and inadequate measuring system wiring may result in unstable or noisy signals.

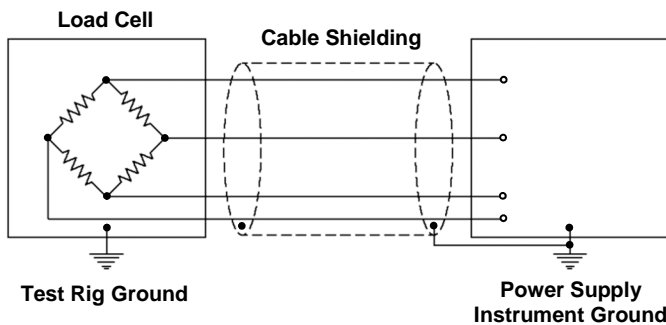

Figure 10 - Grounding

A simple test with a voltmeter connected between the power cord ground and the structure on which the load cell is mounted can confirm that the structure has been properly grounded. If the power cord ground and structure ground are not at the same potential, it may be necessary to provide a secure structure ground, perhaps by driving a copper rod and attaching a ground strap.

6.0 CALIBRATION

Every fastener torque-tension load cell manufactured by PCB Load & Torque has been fully calibrated per ISO/IEC 17025 procedures, and meets all published specifications. Each load cell will come with a calibration certificate designated with matching model and serial numbers. PCB Load & Torque also offers calibration services on an on-going basis.

6.1 Calibration Certificate Description

Calibration reports supplied with fastener torque-tension load cells contain valuable information to assist the customer in use of the equipment. A separate calibration report is provided for tension, compression, and thread torque calibrations. Calibration procedures, equipment, and reports comply with ISO/IEC 17025.

6.1.1 Measured Output

The applied load starting at zero is measured in five increments to full scale. Output (mV/V) is measured at each increment. The straight-line from zero to the full scale measurement is compared to the measured readings at each increment to calculate the error at each load increment. The deviations (% Full Scale) corresponding to non-linearity at each measurement increment are then calculated.

6.1.2 Hysteresis

The difference between the ascending and descending measured readings at 40% of full scale is used to calculate the hysteresis value.

6.1.3 Best Fit Output

The best fit calibration second-order equation has been calculated from the calibration data by the method of least squares. Deviation between measured output and best-fit output is calculated and displayed in the column next to the best-fit output for each measurement increment. The deviations (% Full Scale) of measured outputs from the calculated best fit are tabulated for each measured reading.

6.1.4 Strain Gage Measurements

Table 6 - Strain Gage Measurements

Bridge Resistance:	350 Ohm Nominal
Excitation (Tension):	+P(A) to -P(B) Ohms
Excitation (Thread Torque):	+P(E) to -P(F) Ohms
Signal (Tension):	+S(C) to -S(D) Ohms
Signal (Thread Torque):	+S(G) to -S(J) Ohms
Leakage to Ground:	> 5k GOhm
Bridge Unbalance:	±1.0% Full Scale
Output (Tension):	2.0 mV/V Nominal
Output (Thread Torque):	0.5 mV/V Nominal
Maximum Voltage:	20 VDC

6.1.5 Shunt Calibration Standard Resistor

All tension bridge calibrations use a 43.575K Ohm precision resistor shunt calibration value that is supplied into the calibration report. Thread torque bridge calibrations use a 218.4K Ohm resistor.

6.1.6 Static Error Band (SEB)

The static error band (SEB) is determined by the maximum deviations of the ascending and descending calibration points from the best fit straight line through zero output. The SEB includes the effects of nonlinearity, hysteresis, and non-return to minimum load.

7.0 CROSS-TALK COMPENSATION

When a tensile load is applied to a load cell, it introduces errors in the thread torque readings. Fastener torque-tension load cell manufactured by PCB Load & Torque, Inc. have been cross-talk compensated to minimize this effect. The calibration certificates report the remaining cross-talk so that this value can be subtracted from the thread torque measurement to increase the accuracy of the thread torque reading used for friction coefficient calculations.

8.0 SHUNT CALIBRATION DESCRIPTION

Shunt calibration is used to simulate a known tension or torque load on a load cell. The calibration certificate will indicate which leg of the bridge to apply the shunt resistor to for both tension and torque load simulation. Tension is simulated by inserting the shunt resistor between the +P and +S connector leads. Torque loading is simulated by inserting the shunt resistor between the +S and -P connector leads.

8.1 Resistor Value

The calibration values for each bridge are found on the calibration certificates supplied with each load cell.

Refer to Section 5.1 for the wiring code for the tension and torque bridges.

8.2 Shunt Calibration Process

To perform the shunt calibration, use the following procedure:

1. Stabilize all forces on the load cell. If possible, remove all loads.
2. Set the load indicator display to read exactly 00.000.
3. Connect the shunt resistor to the terminals specified in the calibration certificate, and adjust the span or gain until the display reads the force value stated on the certificate.
4. Repeat steps 1-3 to verify that a valid calibration setting has been obtained.
5. If possible, apply a known load to the measurement system to further verify that the calibration has been accurately set up.

8.3 Estimating Shunt Resistor for a Given Load

The following formula can be used to estimate the approximate value of shunt resistor required to simulate a mechanical load.

$$R_{cal} = (250 * R_b) / (\text{Output}_{FS} * L_{cal})$$

Where:

R_{cal} = Shunt Resistor (K ohms)

R_b = Bridge Resistance (ohms)

Output_{FS} = Full Scale output of the load cell (mV/V)

L_{cal} = Load to be simulated, % of Load Cell Capacity

9.0 MAINTENANCE

Routine maintenance of the fastener torque-tension load cell should include cleaning the electrical connectors, housings, and mounting surfaces with solutions and techniques that will not harm the physical material of construction. Make sure liquids are not allowed to migrate into devices that are not hermetically sealed. Such devices should only be wiped with a damp cloth, and never be submerged or have liquids poured on them. Never use a pressure washer on the load cells.

Yearly calibrations are recommended to ensure that the unit's outputs match the factory specifications.

10.0 TROUBLESHOOTING

Proper performance of a load cell requires careful attention to both electrical and mechanical aspects of the measurement system. A basic understanding of the electrical and mechanical installation requirements is recommended.

10.1 Mechanical Troubleshooting

A mechanical checklist includes:

1. Check for proper installation of fixturing.
2. Check integrity of the fixturing.

10.2 Electrical Troubleshooting

An electrical checklist should start with:

1. Check cables for proper wiring and make sure connections are secure and proper.
2. Inspect for loose or dirty electrical connections.
3. Check for improper shield grounds.
4. Check for proper grounding of the structure that the load cell is mounted on.
5. Check the signal conditioning electronics for proper setup.
6. Check the insulation resistance of shielded conductors for short circuits.
7. Check isolation resistance, load cell flexure to conductors.
8. Check load cell bridge resistances, (A-B, E-F) excitation and (B-C, G-J) the signal leads.
9. Check bridge balance.
10. Keep a record of your observations, correct problems, or contact PCB factory for assistance.

11.0 CALIBRATION / REPAIR SERVICES

PCB Load & Torque offers calibration and repair services. The PCB Calibration Laboratory in Farmington Hills, Michigan is A2LA Accredited per ISO/IEC 17025.

Standard calibration certificates list five force points ascending and one point descending. Additional data points are available at extra cost upon request.

Certificate information includes tabulated measurement variable data zero balance, bridge input/output resistance, computer nonlinearity and hysteresis, static error band (SEB) calculations and entries abilities and traceability statements.

If an initial evaluation shows that a transducer requires repair, PCB will provide the customer with an estimate prior to taking any corrective action.

11.1 RMA / Purchase Order

Please request a return material authorization (RMA) before sending a load cell back to the factory for any reason. For calibration services, if possible, a copy of the purchase order covering the requested services should be included with the returned load cell.

12.0 WARRANTY

Standard warranty, on fastener torque-tension load cells, covers parts and workmanship. For full details, refer to the Warranty Statement supplied with each load cell.

If the load cell is defective for reasons other than overloads, return it to the factory for detailed evaluation. Factory evaluation may show that the load cell is repairable or non-repairable and if repair or replacement will be under warranty. If not under warranty, the customer will be contacted with the cost of repairs and recalibration. Once authorization to proceed is received, a delivery date will be provided.

*Manual Number: 55054
Manual Revision: NR
Revision Date: 1/23/18
ECO Number: 47765*

Model Number
059740-01185

FASTENER TORQUE-TENSION LOAD CELL

Revision: A
ECN #: 52760

	ENGLISH	SI	
Performance			
Measurement Range(Tension)	405k lbf	1,800 kN	[1][2]
Measurement Range(Torque)	5,901 lbf	8,000 Nm	[1][2]
Sensitivity(Tension)	2.0 mV/V	2.0 mV/V	[1][2]
Sensitivity(Torque)	1.0 mV/V	1.0 mV/V	[1][2]
Non-Linearity	± 0.25 % FS	± 0.25 % FS	[2]
Hysteresis	± 0.25 % FS	± 0.25 % FS	[2]
Non-Repeatability	≤ 0.2 % FS	≤ 0.2 % FS	[2]
Cross Talk	± 5.0 % FS	± 5.0 % FS	[2]
Environmental			
Overload Limit	150 % FS	150 % FS	[2]
Temperature Range(Operating)	0 to +200 °F	-18 to +93 °C	
Temperature Range(Compensated)	+70 to +170 °F	+21 to +77 °C	
Temperature Effect on Output(Maximum)	± 0.001 %Reading/°F	± 0.0018 %Reading/°C	[3]
Temperature Effect on Zero	± 0.001 %FS/°F	± 0.0018 %FS/°C	[3][2]
Balance(Maximum)			
Electrical			
Bridge Resistance(Tension)	350 Ohm	350 Ohm	[1]
Bridge Resistance(Torque)	525 Ohm	525 Ohm	[1]
Excitation Voltage(Recommended)	± 10 VDC or VAC rms	± 10 VDC or VAC rms	[4]
Insulation Resistance	> 5 GOhm	> 5 GOhm	
Zero Balance	≤ 2 % FS	≤ 2 % FS	[2]
Output Polarity(Compression)	Positive	Positive	
Output Polarity(Thread Torque CW)	Positive	Positive	
Bridge Current(at 10 VDC)	30 mA	30 mA	
Physical			
Size (Height x Width x Length)	15.63 in x 6.18 in x 14.75 in	397 mm x 157 mm x 375 mm	[5]
Weight	225 lb	102 kg	
Mounting	5/8 in bolts (6)	16 mm bolts (6)	[5]
Housing Material	Stainless Steel	Stainless Steel	
Sensor Material	Steel	Steel	
Sensing Element	Strain Gage	Strain Gage	
Electrical Connector	PT02H-12-10P	PT02H-12-10P	
Stiffness	53x10 ⁶ lbf-ft/radian	72x10 ⁶ N-m/radian	

OPTIONAL VERSIONS

Optional versions have identical specifications and accessories as listed for the standard model except where noted below. More than one option may be used.

NOTES:

- [1]Nominal.
- [2]FS - Full Scale.
- [3]Over compensated operating temperature range.
- [4]Recommended 10 VAC RMS.
- [5]See Outline Drawing 55053 for Complete Dimensions.
- [6]See PCB Declaration of Conformance PS062 for details.

SUPPLIED ACCESSORIES:

- Model 54663-01 Mounting Plate (Base) (1)
- Model 55441-01 Load Cell Clamp (1)
- Model 7122R-02183A 218.4k Ohm Precision Calibration Resistor (1)
- Model 7122R-04352A PRECISION CAL RESISTOR 43.575 kOhm (1)
- Model 72736-01 Clamp Assembly (1)

Entered: ND	Engineer: PE	Sales: DM	Approved: JM	Spec Number:
Date: 05/12/2022	Date: 05/12/2022	Date: 05/12/2022	Date: 05/12/2022	55052



PCB Load & Torque A Division of PCB Piezotronics
24350 Indoplex Circle Farmington Hills, MI 48335
UNITED STATES
Phone: 866-684-7107
E-Mail: LTSales@pcb.com

Web site: www.pcb.com/LoadAndTorque



[6]

All specifications are at room temperature unless otherwise specified.
In the interest of constant product improvement, we reserve the right to change specifications without notice.

55053

PCB Load & Torque Inc. claims proprietary rights in the information disclosed herein. Neither it nor any reproduction thereof will be disclosed to others without the written consent of PCB Load and Torque Inc.

REVISIONS		
REV	DESCRIPTION	ECO
B	UPDATED FASTENER CLAMP - 05.05.22, PTE	52760

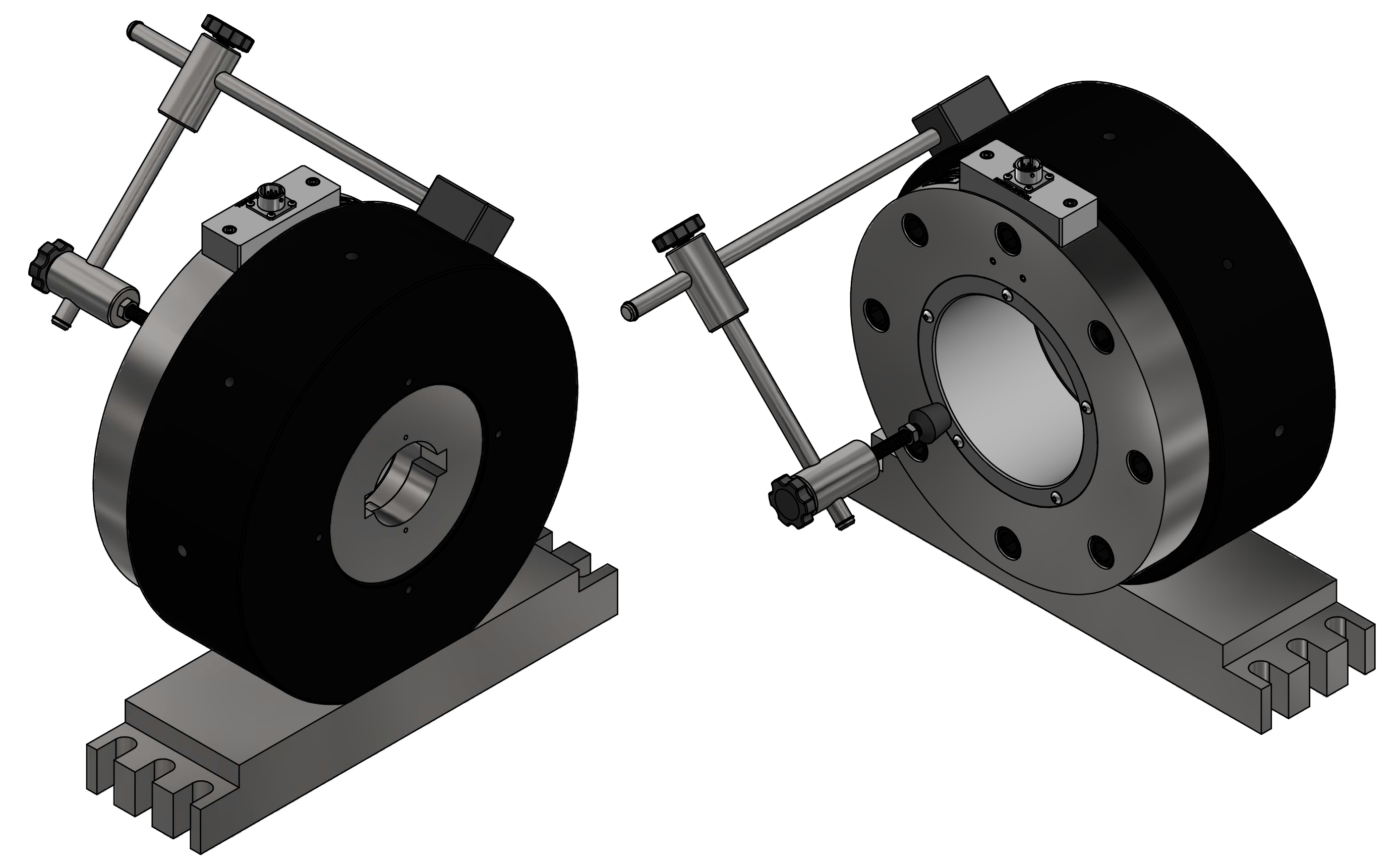
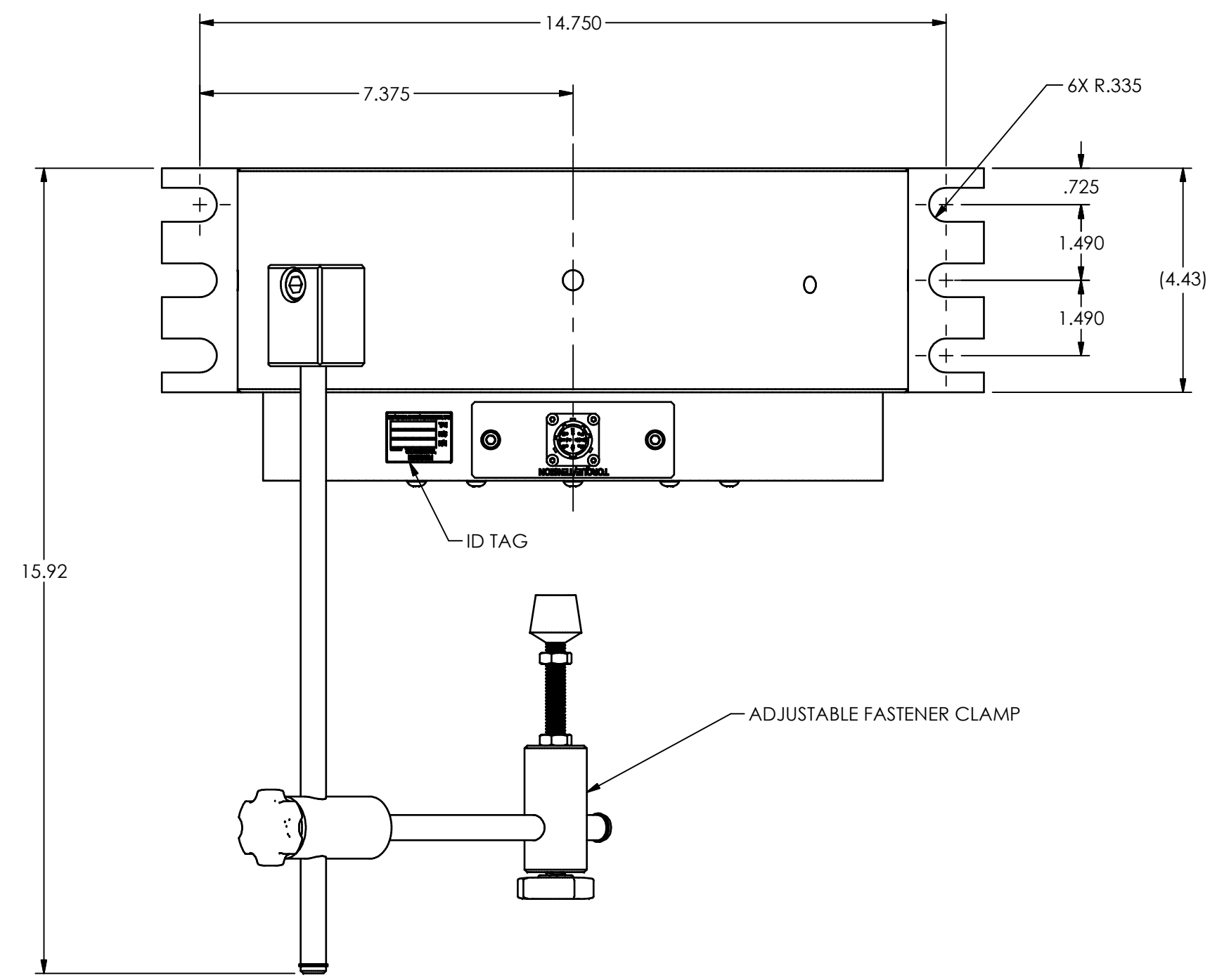

PT02H-12-10P RECEPTACLE
 WIRING CODE:
 PIN A - POWER TENSION
 PIN B - POWER TENSION
 PIN C - SIGNAL TENSION
 PIN D - SIGNAL TENSION
 PIN E - POWER TORQUE
 PIN F - POWER TORQUE
 PIN G - SIGNAL TORQUE
 PIN H - SENSE (TENSION)
 PIN J - SIGNAL TORQUE
 PIN K - SENSE (TENSION)

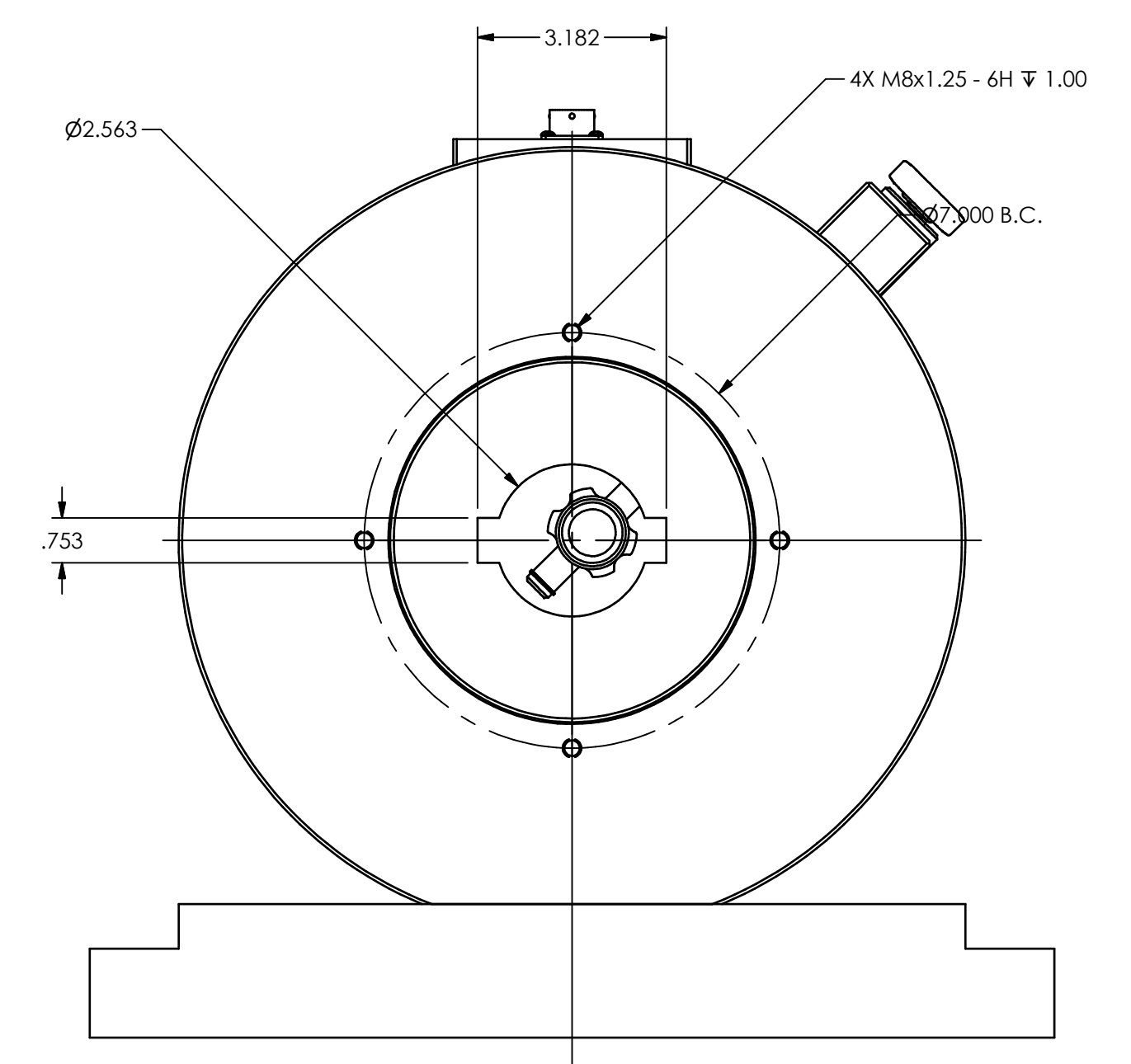
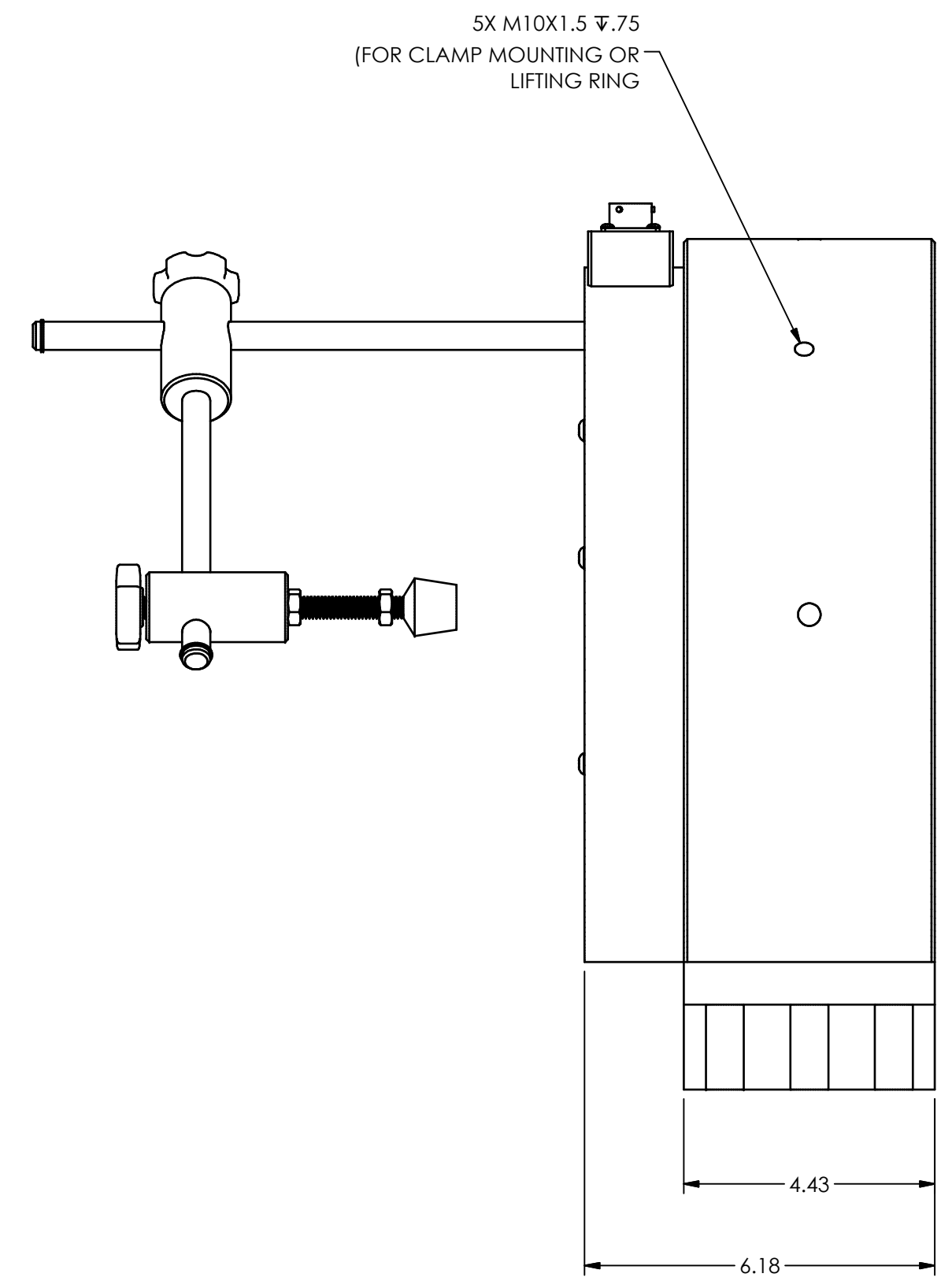
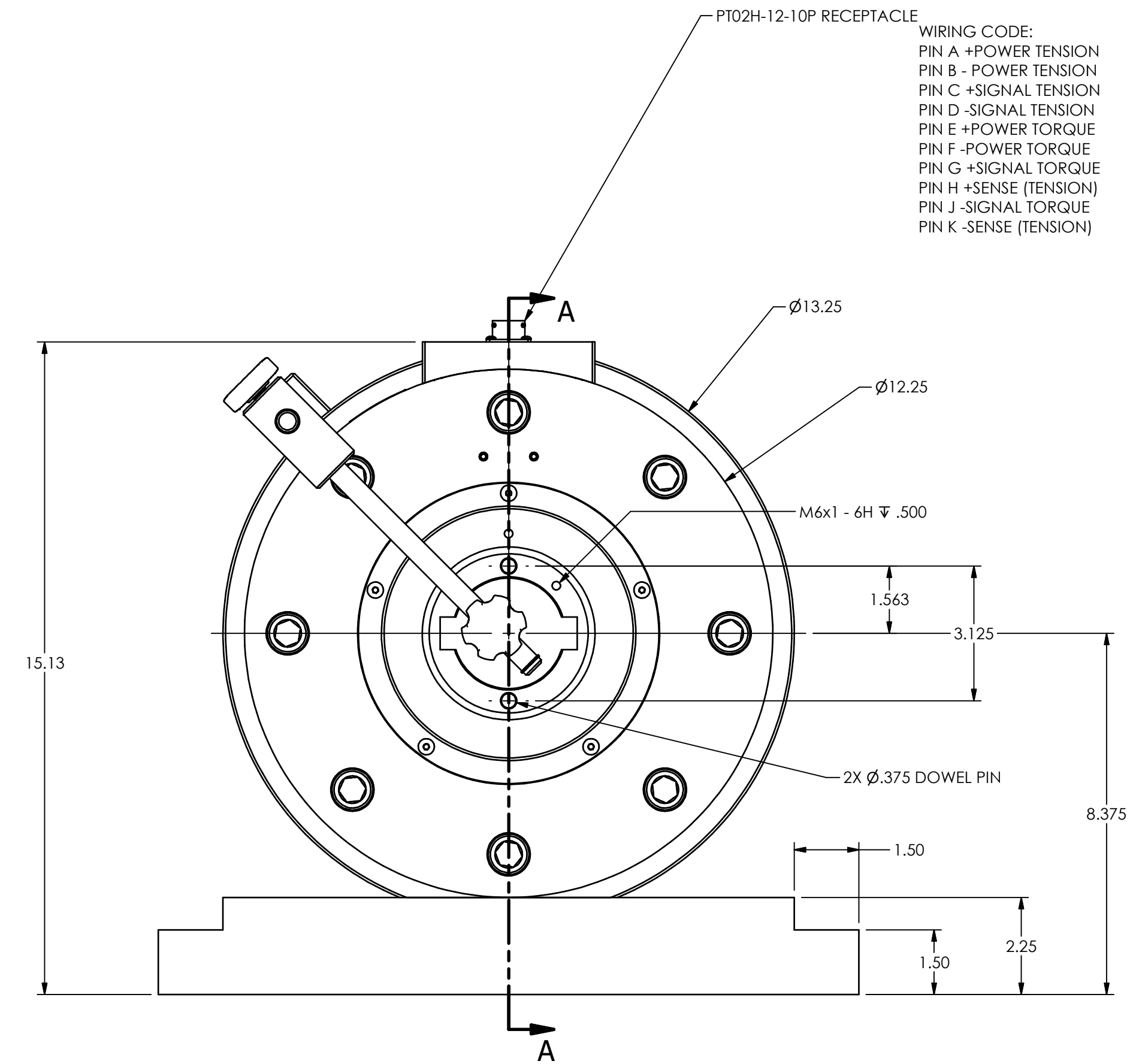
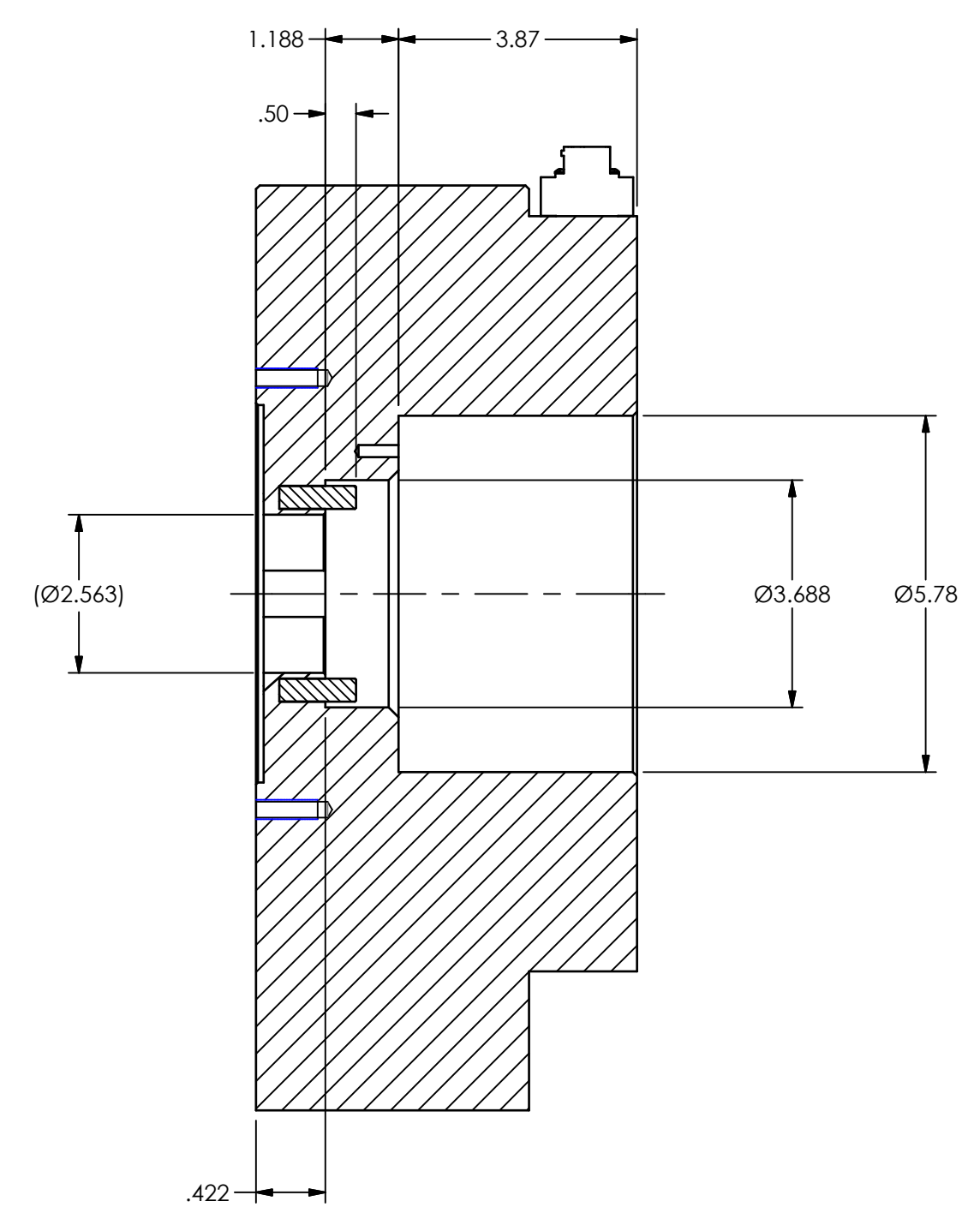

UNLESS OTHERWISE SPECIFIED TOLERANCES ARE:		DRAWN	CHECKED	ENGINEER	PCB LOAD & TORQUE A PCB GROUP COMPANY
DIMENSIONS IN INCHES	DIMENSIONS IN MILLIMETERS [IN BRACKETS]	PTE	JSD	JSD	
DECIMALS XX ±.01 XXX ±.005	DECIMALS X ±0.3 XX ±0.13	03.15.13	05.15.17	03.15.13	24350 Indoplex Circle, Farmington Hills, MI 48335 (714) 684-0001 E-MAIL: info@pcbloadtorque.com DWG. NO. 55053
ANGLES ± 5 DEGREES	ANGLES ± 5 DEGREES	TITLE OUTLINE DRAWING FASTENER TEST HEAD 1800KN - 8000NM			
FILETS AND RADI Ø15 MAX	FILETS AND RADI 0.38 MAX				