



Model 422E51
In-Line Charge Converter
Installation and Operating Manual

**For assistance with the operation of this product,
contact PCB Piezotronics, Inc.**

Toll-free: 800-828-8840
24-hour SensorLine: 716-684-0001
Fax: 716-684-0987
E-mail: info@pcb.com
Web: www.pcb.com



Repair and Maintenance

PCB guarantees Total Customer Satisfaction through its “Lifetime Warranty Plus” on all Platinum Stock Products sold by PCB and through its limited warranties on all other PCB Stock, Standard and Special products. Due to the sophisticated nature of our sensors and associated instrumentation, **field servicing and repair is not recommended and, if attempted, will void the factory warranty.**

Beyond routine calibration and battery replacements where applicable, our products require no user maintenance. Clean electrical connectors, housings, and mounting surfaces with solutions and techniques that will not harm the material of construction. Observe caution when using liquids near devices that are not hermetically sealed. Such devices should only be wiped with a dampened cloth—never saturated or submerged.

In the event that equipment becomes damaged or ceases to operate, our Application Engineers are here to support your troubleshooting efforts 24 hours a day, 7 days a week. Call or email with model and serial number as well as a brief description of the problem.

Calibration

Routine calibration of sensors and associated instrumentation is necessary to maintain measurement accuracy. We recommend calibrating on an annual basis, after exposure to any extreme environmental influence, or prior to any critical test.

PCB Piezotronics is an ISO-9001 certified company whose calibration services are accredited by A2LA to ISO/IEC 17025, with full traceability to SI through N.I.S.T. In addition to our standard calibration services, we also offer specialized tests, including: sensitivity at elevated or cryogenic temperatures, phase response, extended high or low frequency response, extended range, leak testing, hydrostatic pressure testing, and others. For more information, contact your local PCB Piezotronics distributor, sales representative, or factory customer service representative.

Returning Equipment

If factory repair is required, our representatives will provide you with a Return Material Authorization (RMA) number, which we use to reference any information you have already provided and expedite the repair process. This number should be clearly marked on the outside of all returned package(s) and on any packing list(s) accompanying the shipment.

Contact Information

PCB Piezotronics, Inc.
3425 Walden Ave.
Depew, NY14043 USA
Toll-free: (800) 828-8840
24-hour SensorLine: (716) 684-0001
General inquiries: info@pcb.com
Repair inquiries: rma@pcb.com

For a complete list of distributors, global offices and sales representatives, visit our website, www.pcb.com.

Safety Considerations

This product is intended for use by qualified personnel who recognize shock hazards and are familiar with the precautions required to avoid injury. While our equipment is designed with user safety in mind, the protection provided by the equipment may be impaired if equipment is used in a manner not specified by this manual.

Discontinue use and contact our 24-Hour Sensorline if:

- Assistance is needed to safely operate equipment
- Damage is visible or suspected
- Equipment fails or malfunctions

For complete equipment ratings, refer to the enclosed specification sheet for your product.

Definition of Terms and Symbols

The following symbols may be used in this manual:



DANGER

Indicates an immediate hazardous situation, which, if not avoided, may result in death or serious injury.

**CAUTION**

Refers to hazards that could damage the instrument.

**NOTE**

Indicates tips, recommendations and important information. The notes simplify processes and contain additional information on particular operating steps.

The following symbols may be found on the equipment described in this manual:



This symbol on the unit indicates that high voltage may be present. Use standard safety precautions to avoid personal contact with this voltage.



This symbol on the unit indicates that the user should refer to the operating instructions located in the manual.



This symbol indicates safety, earth ground.



PCB工业监视和测量设备 - 中国RoHS2公布表

PCB Industrial Monitoring and Measuring Equipment - China RoHS 2 Disclosure Table

部件名称	有害物质					
	铅 (Pb)	汞 (Hg)	镉 (Cd)	六价铬 (Cr(VI))	多溴联苯 (PBB)	多溴二苯醚 (PBDE)
住房	0	0	0	0	0	0
PCB板	X	0	0	0	0	0
电气连接器	0	0	0	0	0	0
压电晶体	X	0	0	0	0	0
环氧	0	0	0	0	0	0
铁氟龙	0	0	0	0	0	0
电子	0	0	0	0	0	0
厚膜基板	0	0	X	0	0	0
电线	0	0	0	0	0	0
电缆	X	0	0	0	0	0
塑料	0	0	0	0	0	0
焊接	X	0	0	0	0	0
铜合金/黄铜	X	0	0	0	0	0
本表格依据 SJ/T 11364 的规定编制。						
0：表示该有害物质在该部件所有均质材料中的含量均在 GB/T 26572 规定的限量要求以下。						
X：表示该有害物质至少在该部件的某一均质材料中的含量超出 GB/T 26572 规定的限量要求。						
铅是欧洲RoHS指令2011/65/ EU附件三和附件四目前由于允许的豁免。						

CHINA RoHS COMPLIANCE

Component Name	Hazardous Substances					
	Lead (Pb)	Mercury (Hg)	Cadmium (Cd)	Chromium VI Compounds (Cr(VI))	Polybrominated Biphenyls (PBB)	Polybrominated Diphenyl Ethers (PBDE)
Housing	O	O	O	O	O	O
PCB Board	X	O	O	O	O	O
Electrical Connectors	O	O	O	O	O	O
Piezoelectric Crystals	X	O	O	O	O	O
Epoxy	O	O	O	O	O	O
Teflon	O	O	O	O	O	O
Electronics	O	O	O	O	O	O
Thick Film Substrate	O	O	X	O	O	O
Wires	O	O	O	O	O	O
Cables	X	O	O	O	O	O
Plastic	O	O	O	O	O	O
Solder	X	O	O	O	O	O
Copper Alloy/Brass	X	O	O	O	O	O

This table is prepared in accordance with the provisions of SJ/T 11364.

O: Indicates that said hazardous substance contained in all of the homogeneous materials for this part is below the limit requirement of GB/T 26572.

X: Indicates that said hazardous substance contained in at least one of the homogeneous materials for this part is above the limit requirement of GB/T 26572.

Lead is present due to allowed exemption in Annex III or Annex IV of the European RoHS Directive 2011/65/EU.

Operating Instructions

422E5X Series

1.0 INTRODUCTION

The 422E5X series charge amplifiers convert the high impedance charge signal from a charge mode transducer to a low impedance voltage signal.

This conversion is accomplished by the use of a feedback capacitor across an inverting amplifier (Fig 1). The gain of the amplifier is sufficiently high to make the charge amplifier gain virtually independent of input capacitance loading.

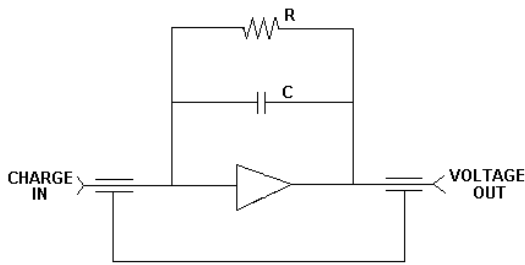

Fig 1

As in all charge amplifiers, the output is inverting. Thus, any sinusoidal signal will experience a 180 degree phase shift.

2.0 DESCRIPTION

The 422E5X series charge amps are .5 inch diameter by 3.4 inch long cylinders. One 10-32 jack functions as input, one BNC jack functions as output. The amplifier operates on power supplied by an ICP[®] power unit via a simple two-wire coaxial cable.

During operation, the electrical charge from the transducer is transferred to the feedback capacitor, resulting in a voltage given by the following equation:

$$V = Q/C_f$$

Q = the charge from the transducer

C_f = the feedback capacitance

The accompanying 9V to 12V bias voltage is typically removed by a 10uF coupling capacitor internal to most PCB ICP[®] power units.

A feedback resistor between 10⁷ and 10¹¹ ohms (depending upon the specific model) neutralizes unwanted, slowly changing signal components resulting from temperature effects and transistor leakage. This resistor, along with the feedback capacitor establishes the time constant (low frequency response).

For low level measurements or remote measurements over long cables, the 422E5X series improves the signal to noise ratio and retains the high frequency signal. The 422E5X series requires little operator attention and operates relatively drift-free in a dynamic mode, an important consideration in multi-channel installations.

3.0 INSTALLATION

Connect the 422E5X to the transducer with low noise cable (003 type only). Standard coaxial cable may be used between the amplifier and power unit, and between the power unit and readout device. (Fig 2)

Connect case of unit to Earth ground with a low impedance connection to conform to CE.

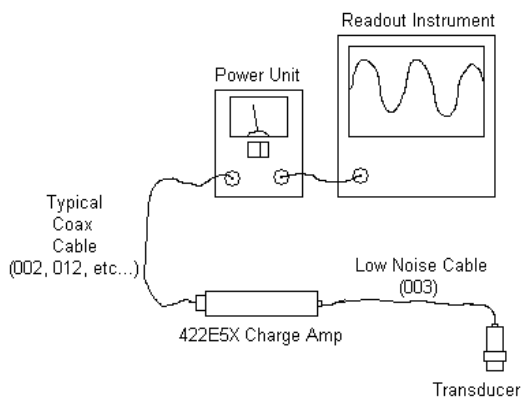

Fig 2

4.0 WARNING SYMBOLS AND TERMS

The following symbols and terms may be found on the equipment described in this manual.



This symbol on the unit indicates that excessive accumulated charges on the input cable can destroy the field effect input transistor. These charges should be grounded out by shorting the center pin of the connector plug to the outer cable conductor with a metallic object before connecting them to the 422E5X charge amp. Care should be taken to avoid touching the input terminal to any object that could possess an electric charge (such as your fingers).



This symbol on the unit indicates that the user should refer to the operating instructions located in the manual.

5.0 OPERATION

After connecting the 422E5X as indicated in Fig 2 Energize the system by turning on the power unit and waiting a few minutes for the amplifier to turn on.

For a simple, self-test circuit, monitor the +9 to +12 V DC bias existing at the output during normal operation with a high impedance voltmeter. Many PCB power units feature such a test circuit (Fig 3).



Fig 3 – A typical bias meter.

5.1 SYSTEM SENSITIVITY

When the sensitivity (pC/unit) of the transducer is known (via calibration) along with the transfer sensitivity of the charge amp (mV/pC), the system sensitivity of the system can be calculated in the following manner:

$$\text{System sens} = (\text{Xdcr Sens})(\text{Amp Sens})$$

System sens is given in (mV/Unit)

Xdcr Sens is given in (pC/Unit)

Amp Sens is given in (mV/pC)

6.0 MAINTENANCE AND REPAIR

The 422E5X charge amplifier is hermetically sealed, and requires no maintenance. If the connectors become dirty, clean with lint-free wipes dampened with isopropyl alcohol.

For extremely dirty or humid environments, the cable connections can be protected with low temperature heat shrink tubing.

Should trouble occur, the factory should be contacted for assistance.

MANUAL NUMBER: 25578

MANUAL REVISION: A

DIN NUMBER - 37900

Model Number 422E51	IN-LINE CHARGE CONVERTER	Revision: E ECN #: 37900
-------------------------------	---------------------------------	-----------------------------

	ENGLISH	SI	
Performance			
Sensitivity(± 5.0 %)(Charge Conversion)	100 mV/pC	100 mV/pC	
Input Range	± 50 pC	± 50 pC	
Overrange	± 8 V	± 8 V	
Low Frequency Response(-5 %)	5 Hz	5 Hz	
High Frequency Response(-5 %)	100 kHz	100 kHz	[3]
Non-Linearity	≤ 1.0 % FS	≤ 1.0 % FS	
Environmental			
Temperature Range(Operating)	-65 to +250 °F	-54 to +121 °C	
Maximum Shock	5000 g pk	49,050 m/s ² pk	
Maximum Vibration(5 to 2000 Hz)	100 g pk	981 m/s ² pk	
Electrical			
Excitation Voltage	18 to 28 VDC	18 to 28 VDC	
Constant Current Excitation	2 to 20 mA	2 to 20 mA	
Output Voltage	± 5.0 V	± 5.0 V	
Output Polarity	Inverted	Inverted	
Output Impedance	100 ohm	100 ohm	
Output Bias Voltage	9 to 13 VDC	9 to 13 VDC	
Maximum Input Voltage	40 V	40 V	
Broadband Electrical Noise(1 to 10,000 Hz)	49 µV	-86 dB	[1]
Spectral Noise(1 Hz)	19 µV/√Hz	-94 dB	[1]
Spectral Noise(10 Hz)	5.1 µV/√Hz	-106 dB	[1]
Spectral Noise(100 Hz)	1.5 µV/√Hz	-116 dB	[1]
Spectral Noise(1 kHz)	0.6 µV/√Hz	-124 dB	[1]
Spectral Noise(10 kHz)	0.2 µV/√Hz	-134 dB	[1]
Capacitance(Feedback)	10 pF	10 pF	
Overload Recovery Time	10 µsec	10 µsec	
Discharge Time Constant	>0.1 sec	>0.1 sec	
Resistance(Feedback)	1.2x10 ¹⁰ ohm	1.2x10 ¹⁰ ohm	[2]
Source Capacitance Loading	0.0005 %/pF	0.0005 %/pF	
Physical			
Housing Material	Stainless Steel	Stainless Steel	
Sealing	Epoxy	Epoxy	
Electrical Connector(Input)	10-32 Coaxial Jack	10-32 Coaxial Jack	
Electrical Connector(Output)	BNC Jack	BNC Jack	
Size (Diameter x Length)	0.52 in x 3.4 in	13 mm x 86 mm	
Weight	1.15 oz	32.7 gm	

OPTIONAL VERSIONS

Optional versions have identical specifications and accessories as listed for the standard model except where noted below. More than one option may be used.

NOTES:

[1] Tested using voltage source and input capacitor equal to the feedback capacitor, to simulate a charge output sensor.

[2] Effective feedback resistance for time constant is 3 times tested value due to circuitry (i.e 1x10E9 = 3x10E9 ohm)

[3] High frequency response may be limited by supply current and output cable length.

[4] See PCB Declaration of Conformance PS024 for details. A low impedance connection from case to earth ground is required to maintain CE compliance.

Entered: DMW	Engineer: KL	Sales: JJM	Approved: BAM	Spec Number:
Date: 12/14/2011	Date: 12/14/2011	Date: 12/14/2011	Date: 12/14/2011	25577



[4]

All specifications are at room temperature unless otherwise specified.
 In the interest of constant product improvement, we reserve the right to change specifications without notice.
 ICP® is a registered trademark of PCB Group, Inc.

PCB PIEZOTRONICS[™]
ELECTRONICS DIVISION

3425 Walden Avenue, Depew, NY 14043

Phone: 716-684-0001
 Fax: 716-684-0987
 E-Mail: electronics@pcb.com

PCB Piezotronics Inc. claims proprietary rights in the information disclosed hereon. Neither it nor any reproduction thereof will be disclosed to others without the written consent of PCB Piezotronics Inc.

REVISIONS

REV	DESCRIPTION	DIN
NR	RELEASED TO DRAFTING	37900

52113

STANDARD INPUT CONNECTOR

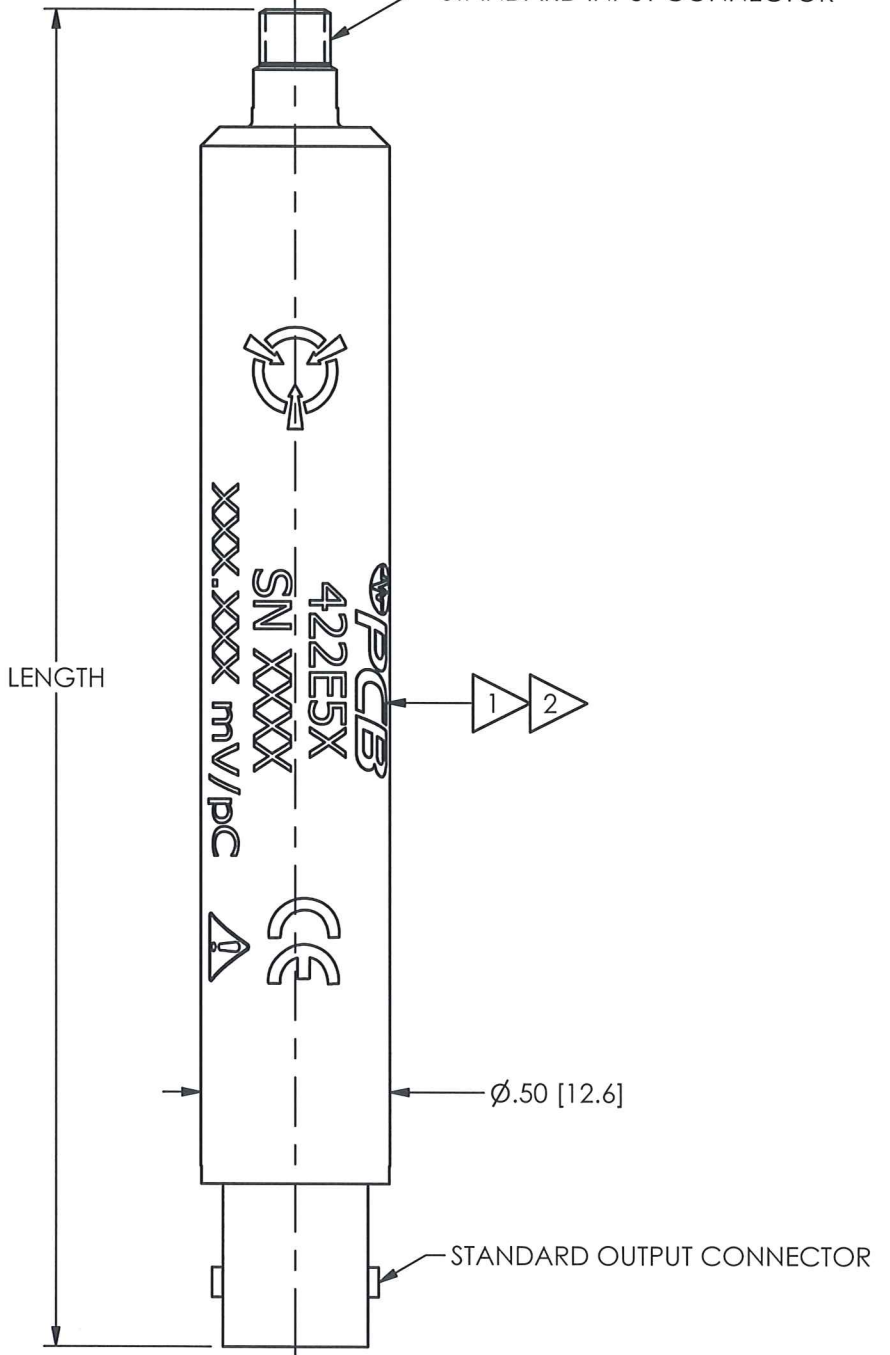

AVAILABLE CONNECTOR OPTIONS:

STANDARD MODEL NUMBER
INPUT: 10-32 MICRO DOT JACK
OUTPUT: BNC JACK
LENGTH: 3.4 [85]

MODEL NO./A
INPUT: 10-32 MICRO-DOT JACK
OUTPUT: 10-32 MICRO-DOT JACK
LENGTH: 3.0 [76]

MODEL NO./C
INPUT: 10-32 MICRO-DOT JACK
OUTPUT: BNC PLUG
LENGTH: 3.2 [81]

MODEL NO./D
INPUT: BNC JACK
OUTPUT: BNC JACK
LENGTH: 4.2 [107]

2 ETCH WITH "IN ← → OUT" TO INDICATE PROPER ORIENTATION.

1 ETCH WITH NORMAL SENSITIVITY, AS IT APPEARS ON SPEC SHEET.

UNLESS OTHERWISE SPECIFIED TOLERANCES ARE:

DIMENSIONS IN INCHES	DIMENSIONS IN MILLIMETERS [IN BRACKETS]
DECIMALS XX ±.03 XXX ±.010	DECIMALS X ± 0.8 XX ± 0.25
ANGLES ± 2 DEGREES	ANGLES ± 2 DEGREES
FILLETS AND RADII .003 - .005	FILLETS AND RADII 0.07 - 0.13

DRAWN		CHECKED		ENGINEER	
SMB	12/22/11	<i>[Signature]</i>	<i>[Signature]</i>	KEN L	12/22/11
TITLE					
OUTLINE DRAWING MODEL 422E5X SERIES IN-LINE CHARGE AMPLIFIER					

PCB PIEZOTRONICS INC.
3425 WALDEN AVE. DEPEW, NY 14043
(716) 684-0001 E-MAIL: sales@pcb.com

CODE IDENT. NO. 52681	DWG. NO. 52113
SCALE: 2X	SHEET 1 OF 1