



MODEL 2110E

110 LBF ELECTRODYNAMIC EXCITER

- Innovative dual-purpose design integrates platform table for traditional vibration testing with a through-hole armature for modal studies
- 3.25 in (8.3 cm) diameter platform table supports payloads up to 10 lb (4.5 kg)
- Through-hole armature with chuck and collet attachment provides simple set-up with modal stingers
- Lightweight and portable - weighing just 56 lb (25 kg)
- Trunnion base with EasyTurn™ handles provides flexibility and full rotation when positioning and aligning the shaker
- 1.0 in (25.4 mm) stroke and wide frequency range (to 6500 Hz) support broad range of applications
- Forced air cooling sufficient to meet full shaker performance (110 lbf/489N) specifications

DUAL-PURPOSE SHAKER

The Modal Shop's Dual-Purpose Shaker Model 2110E is a compact and powerful vibration shaker, providing up to 110 lbf pk sine force. A large armature (3.25 in / 8.3 cm diameter platform table supporting payloads up to 10 lb / 4.5 kg) makes the shaker ideal for traditional vibration control testing of components and subassemblies. The unit is also designed with a through-hole armature and includes a chuck and collet attachment, providing simple set-up with stingers for experimental modal analysis applications. When used in this configuration, these stingers greatly simplify test setup with an easy connection to the force sensor and test structure, and help decouple cross-axis force inputs, minimizing force measurement errors.

The shaker is supplied in a standard trunnion mounting base with EasyTurn™ handles, allowing rotation for easy set-up and alignment. It also facilitates bolting the shaker in place either with or without vibration isolation mounts. Features include a rugged suspension system which minimizes test fixture requirements and related fixture guidance problems. Its 1 in (25.4 mm) stroke, wide frequency range (useable to 6500 Hz), and innovative dual-purpose platform table design support a broad range of applications. The shaker field supply is integrated into the 2050E09-FS power amplifier and includes a cooling interlock to protect the shaker.

SPECIFICATIONS	
Performance	
Output Force, sine pk, forced air cooling	110 lbf (489 N) ^[1]
Output Force, random RMS, forced air cooling	45 lbf (200 N) ^[1]
Output Force, shock pk (50 ms)	110 lbf (489 N)
Stroke Length, continuous pk-pk	1.0 in (25.4 mm)
Stroke Length, between stops	1.03 in (26.2 mm)
Frequency Range, nominal	DC – 6500 Hz ^[2]
Fundamental Resonance	> 4000 Hz ^[2]
Maximum Velocity	70 in/s pk (1.8 m/s pk)
Maximum Acceleration, bare table	110 g pk
Maximum Acceleration, 1 lb (0.45 kg) load	55 g pk
Maximum Acceleration, 5 lb (2.38 kg) load	18 g pk
Maximum Acceleration, resonance	150 g pk
Maximum Acceleration, peak shock	200 g pk
Maximum Payload, typical	10 lb (4.5 kg)
Physical	
Platform Mounting Thread	5x 10-32 ^[3] ^[4]
Armature Weight	1 lb (0.45 kg)
Suspension Stiffness	90 lbf/in (15.8 N/mm)
Rated Drive Current, forced air cooling	22 A RMS
Stray Magnetic Field, 1.5 in (33 mm) above table	< 20 Gauss
Stray Magnetic Field, 1.0 in (25 mm) from body	< 25 Gauss
Cooling Air	100 cfm/15 in H ₂ O ^[1]
Dimensions (H x W x D), nominal	11.7 x 12.5 x 6.5 in (297 x 318 x 165 mm) ^[5]
Weight, nominal	56 lb (25 kg)
Temperature Operating Range	40 – 100 °F (4 – 38 °C), < 85% RH
Field Power Supply	15 V, 12 ADC, nominal ^[6]
Supplied Accessories ^[7]	
Trunnion base with EasyTurn™ handles	
Shaker cable 10 ft (3 m)	
2000X03 Shaker Accessory Kit (includes case, modal stingers, chuck with collets, wrenches, spare fuse, & other accessories)	
Required Accessories	
2050E09-FS	Power Amplifier, 900 W, selectable voltage / current control / field power supply
2000X04	Cooling Package for Shakers, regenerative vacuum, single phase ^[5]

Suggested Accessories	
2050A	Lateral Excitation Stand
2000X01	Head Expander
2000X02	Base Isolation Mounts
PCB 288D01	ICP® impedance head driving point sensor
PCB 208	Series ICP® force sensors

- [1] Full force range requires forced air cooling with 2050E09-FS power amplifier.
 [2] Load dependent, stated specifications based upon bare table.
 [3] Includes 10-32 to chuck/collet adaptor for through-hole armature/stinger applications.
 [4] Inserts also available with M5 threads.
 [5] Reference outline drawing for details.
 [6] Power provided by the 2050E09-FS power amplifier.
 [7] Always included if ordered as K2110E110 shaker system.

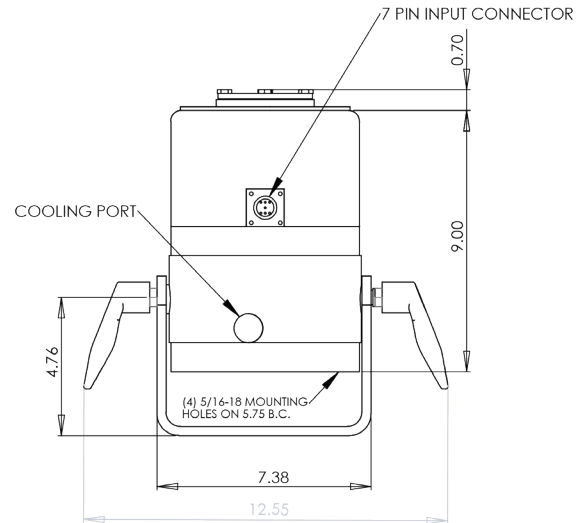

Model 2110E - Front View

Dimensions in inches

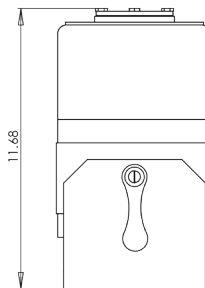

Model 2110E - Side View

Dimensions in inches