



MODEL 2004E/2007E

MINIATURE ELECTRODYNAMIC SHAKERS

- Up to 7 pounds (31 N) pk sine force
- Up to 0.5 inch (1.27 cm) stroke
- Payloads up to 2 lb (0.91 kg)
- 10-32 threaded mounting insert
- Wide frequency band operation up to 11 kHz
- Trunnion mounting base with EasyTurn™ handles

TYPICAL APPLICATIONS

- General vibration testing
 - Small components
 - Sub-assemblies
 - Biomedical
- Experimental modal analysis
- Educational laboratory research

PORTABLE EXCITATION

These electrodynamic exciters are small, portable permanent magnet shakers. They are ideally suited for general purpose vibration testing of small components and sub-assemblies, or as excitation transducers for modal, academic, biomedical, or laboratory research. The shakers feature extremely rugged suspension systems using carbon fiber composite leaf armature flexures. Isolated linear bearings provide low distortion and eliminate the need for reaction wrenches when mounting loads to the armature. A trunnion base with EasyTurn™ handles allows for convenient mounting and positioning. Each transducer is delivered with a variety of 10-32 nylon stingers which provide electrical isolation as an attachment mechanism to test articles.

The compact design and portability make the 2004E/2007E mini-shakers a very versatile, accessible, and popular solution for test and instrumentation engineers. They are ideally suited for general purpose vibration testing of small components, electronic assemblies, Integrated Circuits and Printed Circuit Boards, or as an excitation transducer for experimental modal, academic, biomedical or laboratory research.

SPECIFICATIONS

Performance	2004E	2007E
Output Force, sine pk		
Natural Air Cooling	4.5 lbf (20 N)	7 lbf (31 N)
Output Force, random RMS		
Natural Air Cooling	3 lbf (13.3 N)	5 lbf (22 N)
Output Force, shock pk	9 lbf (40 N)	15 lbf (67 N)
Stroke Length		
Continuous pk-pk	0.2 in (5 mm)	0.5 in (13 mm)
Between Stops	0.35 in (9 mm)	0.55 in (14 mm)
Frequency Range ^[1]	DC-11 kHz	DC-9 kHz
Acceleration ^{[1] [2]}		
No Load	64 g _{pk}	70 g _{pk}
0.1 lb load	26 g _{pk}	35 g _{pk}
1 lb load	4.2 g _{pk}	6.4 g _{pk}
2 lb load	2.2 g _{pk}	3.3 g _{pk}
Protection Features	Over-current (in-line fuse)	
Maximum Current	5 A	8 A
DC Resistance, armature, nominal	1.5 Ω	0.37 Ω
Physical		
Armature Mass, nominal	0.07 lb (0.032 kg)	0.1 lb (0.045 kg)
Suspension Stiffness, nominal	15 lbf/in (2.63 N/mm)	
Dimensions (H x W x D), nominal	5.3 x 6.75 x 3.5 in (135 x 171 x 89 mm)	
Weight	6 lb (2.72 kg)	
Electrical Connector	7 ft (2.13 m) Integral cable to ring terminals	
Table Mounting	10-32 thread	
Supplied Accessories		
2110G06 Nylon Stinger kit, pack of three		
Trunnion base with EasyTurn™ handles and mounting holes		
Related Products		
2100E21	SmartAmp™ Power Amplifier 400 W, 92% efficient, continuous gain adjustment	
208C01	Multi-purpose, ICP® force sensor, 10 lb (45 N) comp., 10 lb (45 N) tension, 500 mV/lb (10 mV/N)	
288D01	ICP® impedance head, force/accel: Force: 100 mV/lb (22.4 mV/N); Accel: 100 mV/g (10.2 mV/(m/s ²))	
2110 Series	Stinger kit, 10-32 threaded nylon, various lengths, pack of three	
2120 Series	Stinger kit, 10-32 threaded stainless-steel, various lengths, pack of three	

[1] Load dependent.

[2] Please see systems ratings for additional specifications.

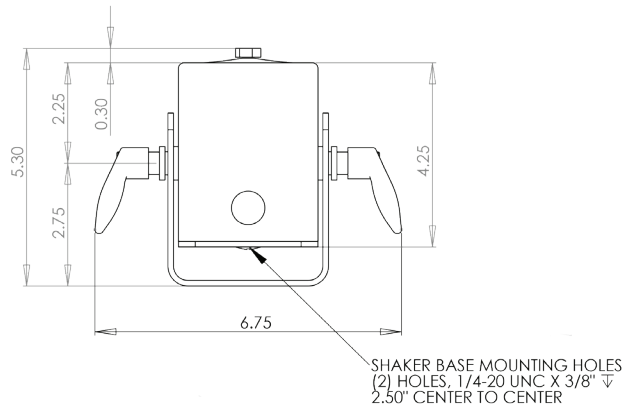

Model 2004E-2007E - Front View

Dimensions in inches

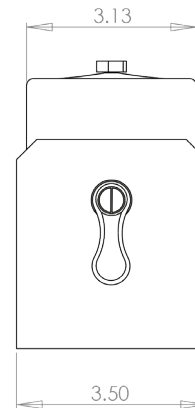

Model 2004E-2007E - Side View

Dimensions in inches