

66771

PCB Load & Torque (A Division of PCB Piezotronics, Inc.) claims proprietary rights in the information disclosed herein. Neither it nor any reproduction thereof will be disclosed to others without the written consent of PCB Load and Torque.

REVISIONS		
REV	DESCRIPTION	ECO
C	UPDATED FASTENER CLAMP - 05.05.22, PTE	52760

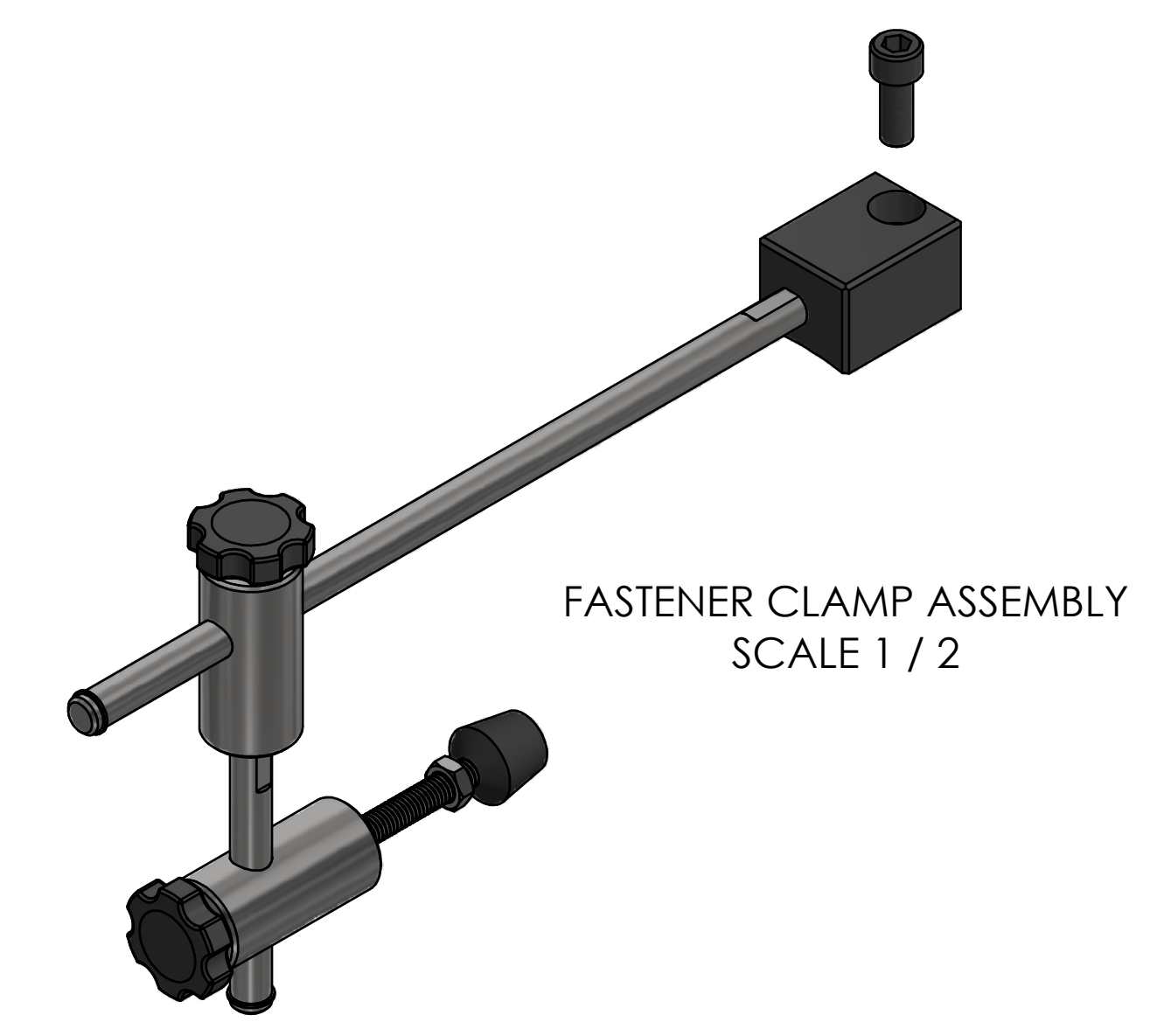
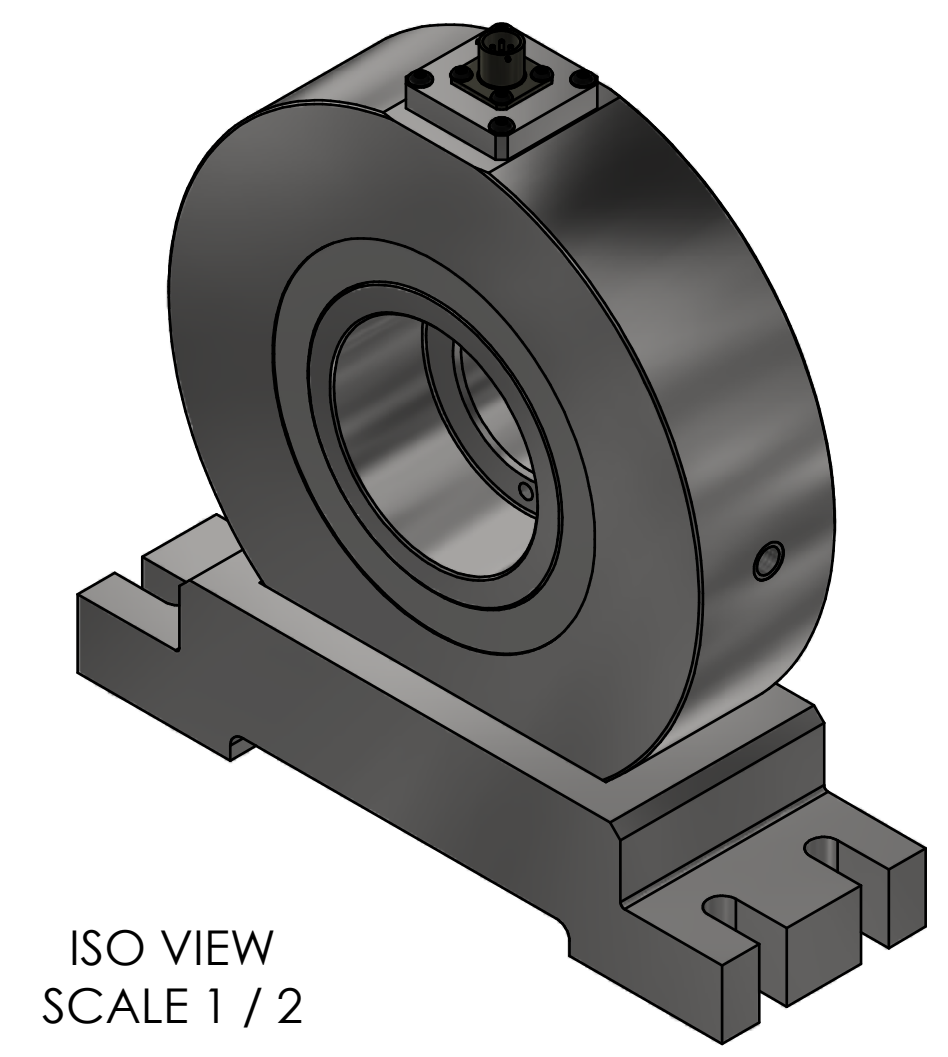
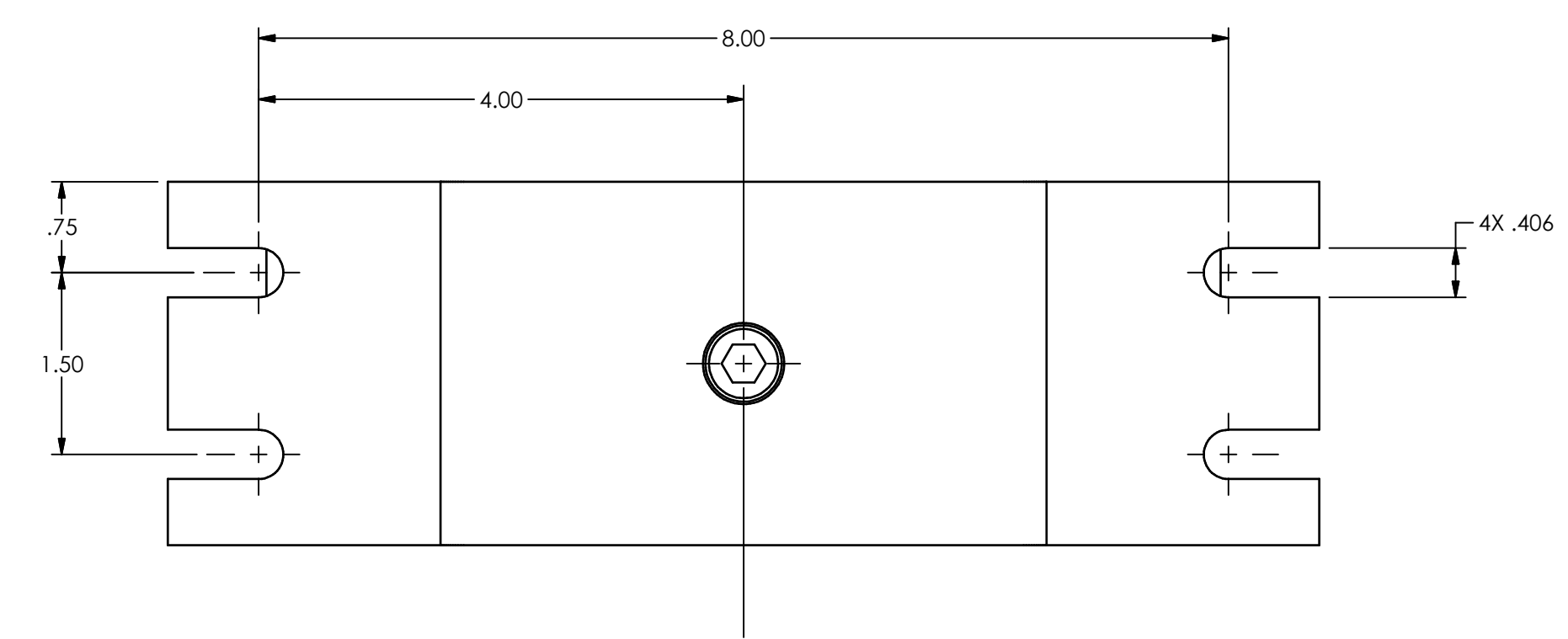
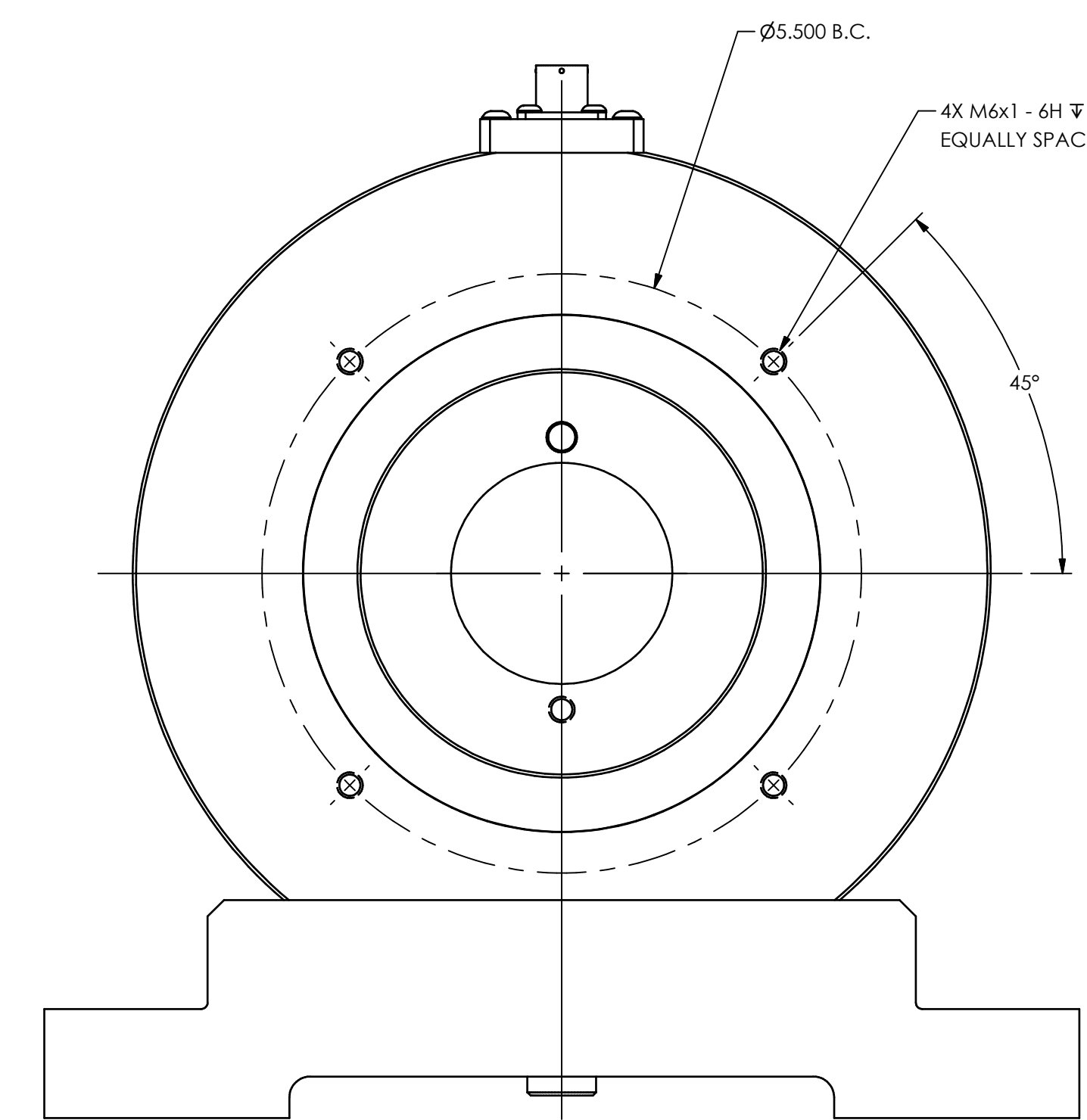
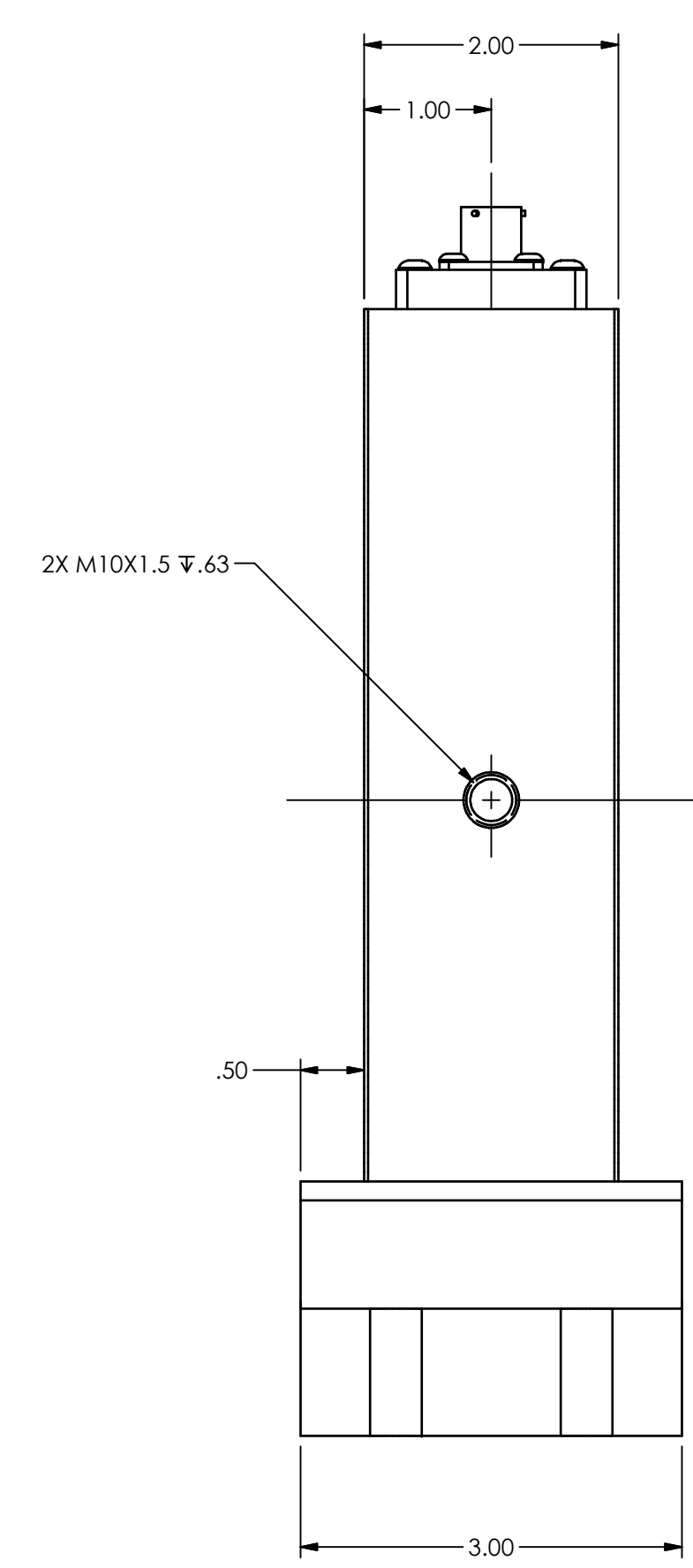
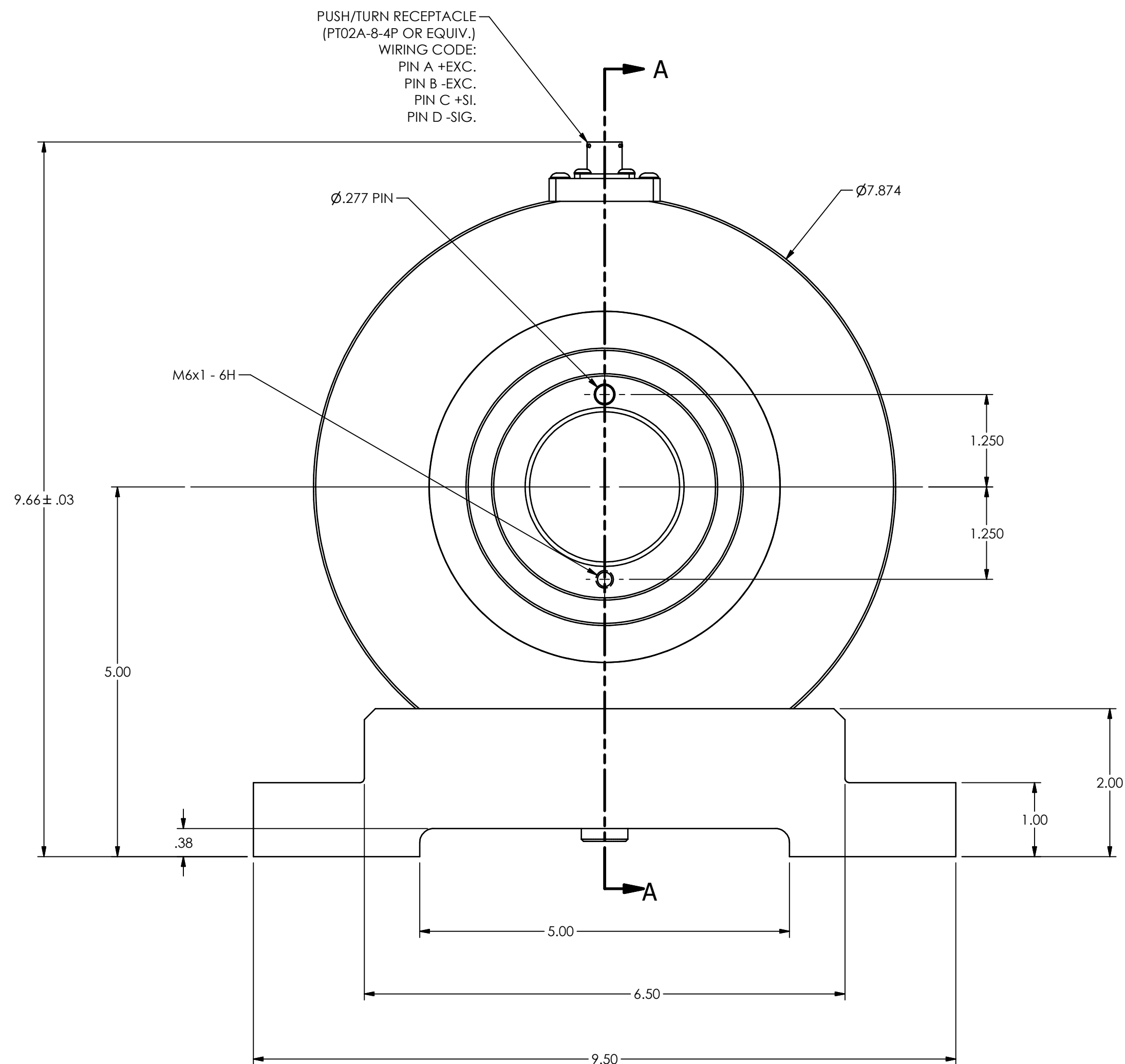
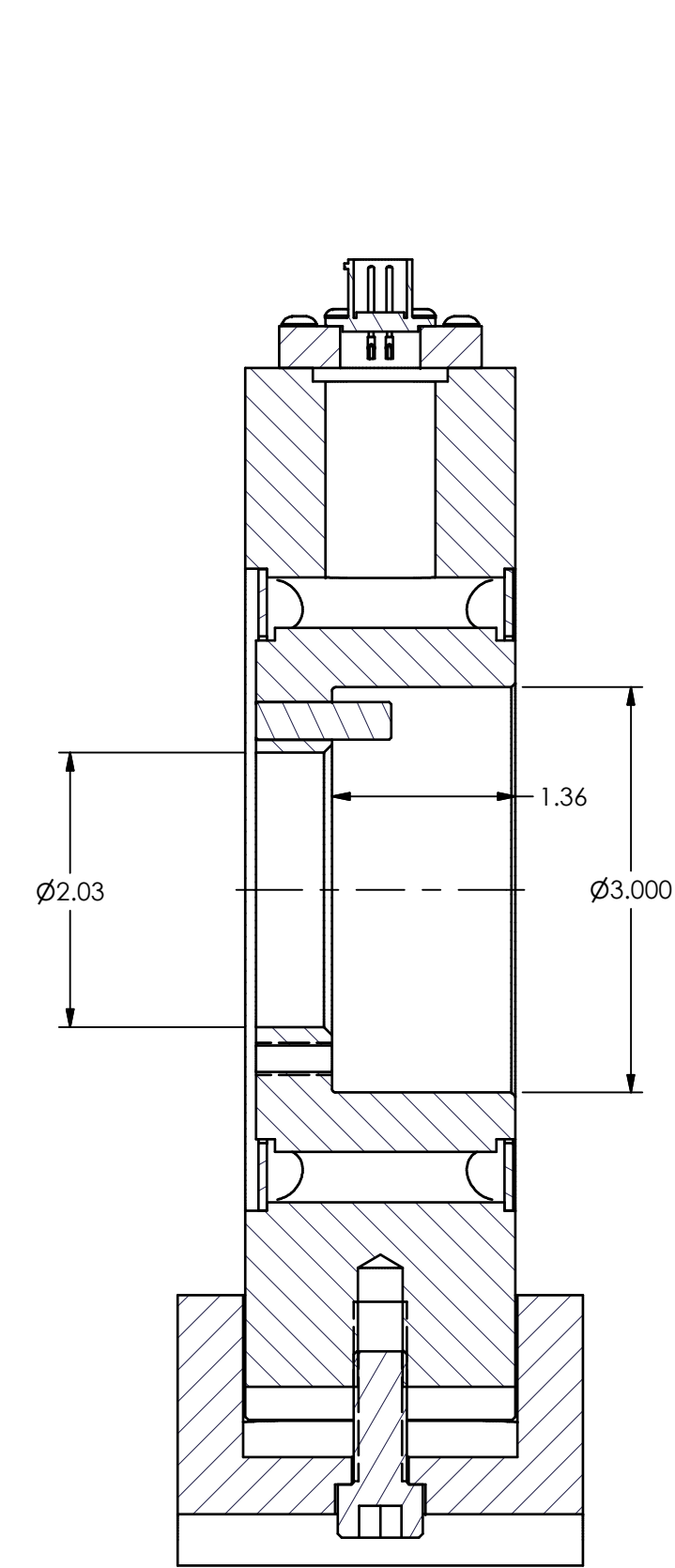

UNLESS OTHERWISE SPECIFIED TOLERANCES ARE:		DRAWN	CHECKED	ENGINEER	PCB LOAD & TORQUE A PCB GROUP COMPANY
DIMENSIONS IN INCHES	DIMENSIONS IN MILLIMETERS [IN BRACKETS]	PTE	DJM	JSD	
DECIMALS XX ±.01 XXX ±.005	DECIMALS X ±0.3 XX ±0.13	03.07.17	03.10.17	03.07.17	24350 Indoplex Circle, Farmington Hills, MI 48335 (748) 888-8260 E-MAIL: info@pctb.com
ANGLES ± 5 DEGREES	ANGLES ± 5 DEGREES	TITLE OUTLINE DRAWING 9810 SERIES 300 AND 500KN CAP. CLAMP FORCE LOAD CELL			
FILLETS AND RADI Ø15 MAX	FILLETS AND RADI Ø.38 MAX	SCALE: 3/4			SHEET 1 OF 1