



Powering ICP[®] Sensors With Signal Conditioners

Written By

Meredith Christman, IMI division of PCB Piezotronics, Depew, New York

Powering ICP® Sensors with Signal Conditioners

Article by:

Meredith Christman, IMI division of PCB Piezotronics, Depew, New York

IMI Sensors produces two broad categories of sensors- charge sensors (pC/unit) and ICP® sensors (mV/unit). Charge sensors do not include a built-in amplifier and have a high-impedance output signal while ICP® sensors include a built-in amplifier and have a low-impedance output signal. The provision of a low-impedance output signal is especially important in dirty industrial environments and in applications where long cable lengths are required. In order to properly power the amplifier in an ICP® sensor, the sensor requires a 18-30 VDC, fixed constant current power source that can operate on a two-wire system.

In most applications, ICP® sensor power is provided by a signal conditioner. The operation of a signal conditioner is illustrated by the wiring diagram in Figure 1. All signal conditioners consist of four major components:

- 18-30 VDC power source
- Current-regulating diode
- Voltmeter
- Decoupling capacitor

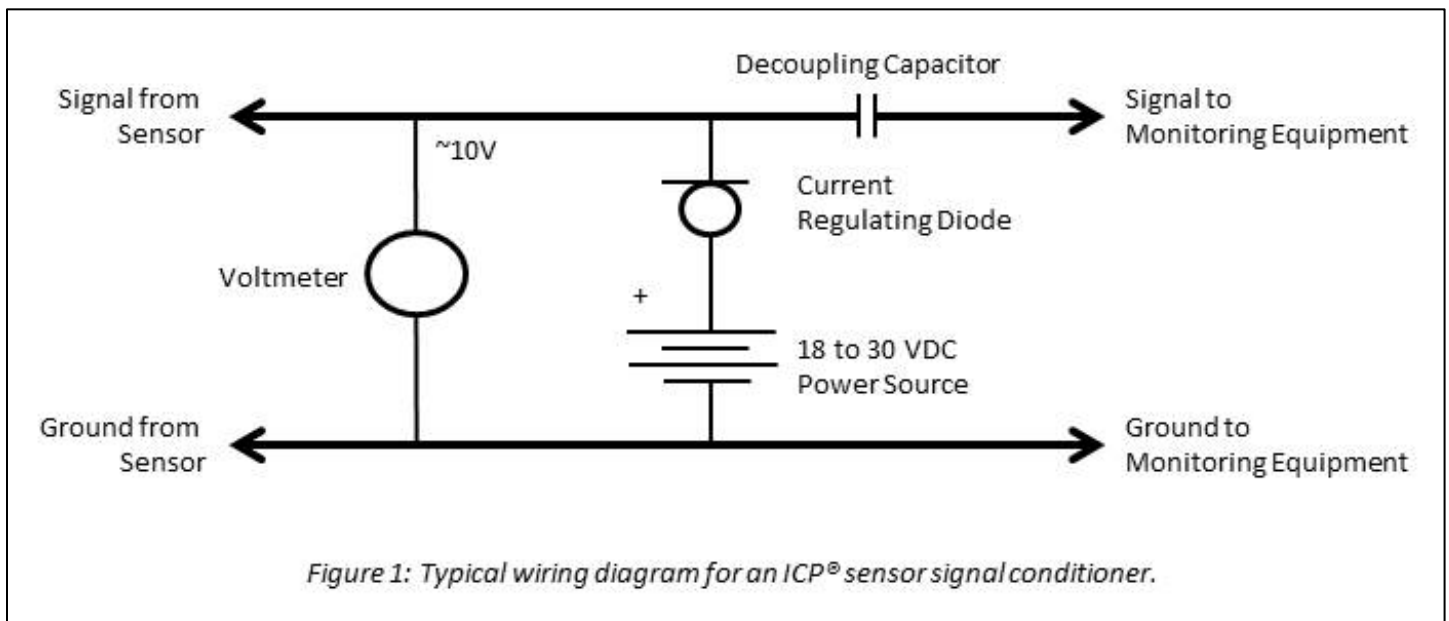

The transmission of power to an ICP® sensor begins with the signal conditioner's connection to a supply voltage. The supply voltage, which must be 18-30 VDC, can be derived from line or battery power. Figure 2 illustrates examples of line-powered and battery-powered signal conditioners. Most line-powered signal conditioners supply 24 VDC power to the sensor as the signal conditioner is connected to an external 24VDC power source. The power provided by a battery-powered signal conditioner can vary depending on the number and voltage of the batteries included in the signal conditioner. (For example, the 480C02 contains three 9V batteries and therefore provides 27VDC.)

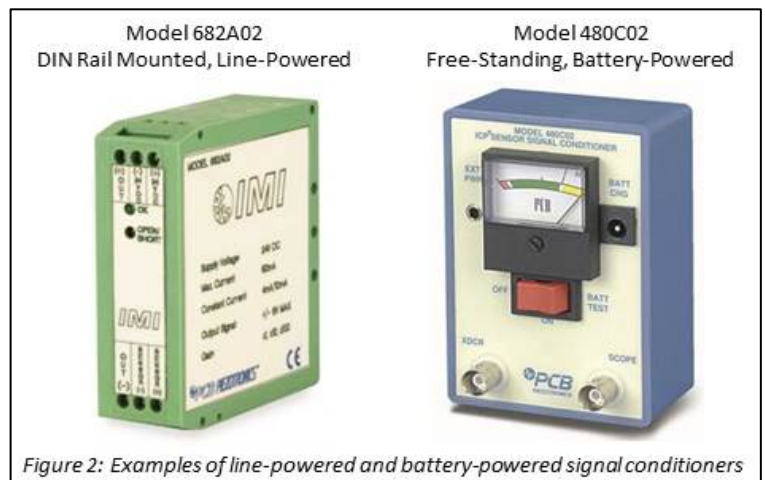

Once introduced into the signal conditioner, the 18-30 VDC power passes through a current-regulating diode before being transmitted to the ICP® sensor as ICP® sensors require a fixed constant current between 2 and 20 mA. (Present technology limits the diode to a 4 mA maximum rating. However, several diodes can be placed in parallel to supply higher currents for driving long cable lengths.) Some signal conditioners provide a user interface to configure the current. There is an approximate 1V drop across the diode. Figure 3 illustrates the physical configuration of a diode when compared to current flow as correct orientation of the diode is critical for proper operation.

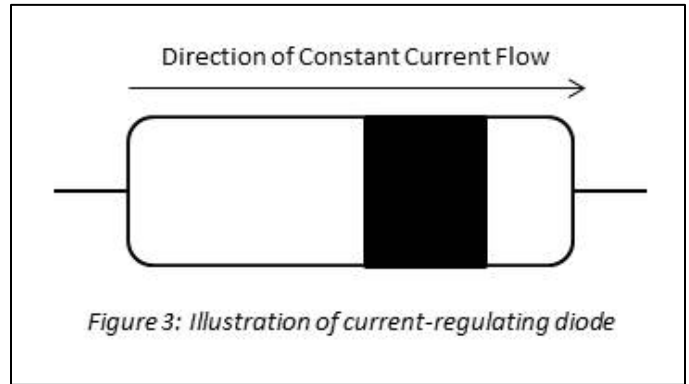

Once the power has passed through the current-regulating diode, it is transmitted to the ICP® sensor via two-conductor cable with one conductor acting as the ground and the other conductor transmitting both the power to the sensor as well as the output signal from the sensor. The portion of the voltage used to power the sensor's amplifier is called the bias voltage and is usually in the range of 8-12 VDC. (The voltmeter monitors this bias voltage and is useful for checking sensor operation and detecting open or shorted cables and connections.) The output signal is an AC dynamic signal that rides on top of the bias voltage when being transmitted back to the signal conditioner.

When the output signal is received back at the signal conditioner, the DC bias voltage must be decoupled from the AC signal voltage in order to record accurate data. The 10-30 μ F capacitor shifts the signal level to essentially eliminate the sensor bias voltage, providing a drift-free AC mode operation. Subsequent to being de-coupled, the signal voltage is then often gained (ie. amplified) before being sent to the monitoring equipment. The most common options for amplification are x1, x10 and x100.

Once the bias voltage is decoupled from the signal voltage, the signal voltage is then transmitted to the monitoring equipment via a two wire system.



3425 Walden Avenue, Depew, NY 14043 USA

pcb.com/imi-sensors | imi@pcb.com | 800 959 4464 | +1 716 684 0003

© 2021 PCB Piezotronics - all rights reserved. PCB Piezotronics is a wholly-owned subsidiary of Amphenol Corporation. Endevo is an assumed name of PCB Piezotronics of North Carolina, Inc., which is a wholly-owned subsidiary of PCB Piezotronics, Inc. Accumetrics, Inc. and The Modal Shop, Inc. are wholly-owned subsidiaries of PCB Piezotronics, Inc. IMI Sensors and Larson Davis are Divisions of PCB Piezotronics, Inc. Except for any third party marks for which attribution is provided herein, the company names and product names used in this document may be the registered trademarks or unregistered trademarks of PCB Piezotronics, Inc., PCB Piezotronics of North Carolina, Inc. (d/b/a Endevo), The Modal Shop, Inc. or Accumetrics, Inc. Detailed trademark ownership information is available at www.pcb.com/trademarkownership.

WPL_74_1121