

# Magnet Mounting Techniques for Machinery Vibration Monitoring

Written By

Gene Bradbury, Praxair Technology Center  
Eric Saller, IMI division of PCB Piezotronics

Edited by

Meredith Christman, IMI division of PCB Piezotronics

## **Magnet Mounting Techniques for Machinery Vibration Monitoring**

### **Original Article by:**

**Gene Bradbury,** Praxair Technology Center, Tonawanda, New York  
**Eric Saller,** IMI division of PCB Piezotronics, Depew, New York

### **Editing and Addendum by:**

**Meredith Christman,** IMI division of PCB Piezotronics, Depew, New York

**This article discusses magnet-mounting techniques for accelerometers. These techniques allowed Praxair, Inc., a leader in the air separation and purification industry, to institute a company-wide vibration data acquisition and analysis system that monitors machinery health at several hundred Praxair facilities across North America, as well as all locations in South America, Europe and Asia.**

Air separation facilities use a large variety of rotating and reciprocating machinery. Predictive maintenance for this type of equipment involves monthly monitoring at hundreds of measurement points at each plant. Vibration data including high-frequency measurements in the 20 kHz range provide valuable indications of machinery health.

Vibration analysts at Praxair concluded that a comprehensive, accelerometer-based predictive maintenance program that linked plants across the country in a nationwide network would be ideal except for the problem of mounting requirements for high-frequency measurements. Conventional wisdom held that accelerometers needed to be stud mounted in order to provide accurate readings at high frequencies. For Praxair, stud mounting an accelerometer at hundreds of measurement points would be a task so time-consuming and tedious that it would pose serious concerns about cost-effectiveness and data accuracy.

To successfully implement the program, vibration analysts needed a quick-attach/quick-disconnect method of accelerometer mounting capable of providing accurate readings at high frequencies. In cooperation with PCB Piezotronics, Praxair developed and tested an innovative magnet-mounting technique which met all requirements for ease of use and accuracy at high frequencies. Development of this technique has led to worldwide implementation of the vibration monitoring program at Praxair facilities. Since its implementation, the program has helped increase equipment availability at Praxair plants by several percentage points and regularly identifies a variety of equipment problems prior to catastrophic failure.

### **Vibration Monitoring in the Air Separation industry**

Air separation is unique among major chemical industries in many ways. Air separation plants are typically smaller, both in physical dimensions and in the inventory of mechanical equipment. Because on-silo staff is also small, plant personnel are expected to develop a diverse range of skills. This limits the time available for specialization in any one area, such as vibration analysis.

Praxair facilities (which include more than 400 plants in the U.S) vary considerably in design, equipment, size and date of construction. Process equipment ranges in size from under 100 HP to over 35,000 HP. The most familiar process involves the use of compressors and expansion turbines for refrigeration, liquefaction and separation of air into its primary constituents: nitrogen, oxygen, argon, etc. Several different plant designs are used to vary the quantity and purity required to meet customer needs, as well as to handle other gases such as hydrogen, helium and carbon dioxide.

While the plants are all different, there are several common factors. A typical facility operates 24 hours a day, 365 days per year. When unexpected, catastrophic equipment failures occur, they can result in downtime for the entire plant. Adding to the expense of downtime is the fact that it may take several hours to regain process purity once the problem has been solved and the plant goes back on stream.

## Background of Preventive Maintenance

Praxair had been active in utilizing predictive and proactive maintenance strategies for many years. Before implementing its new program, Praxair's preventative maintenance called for overhauling every major machine at regular intervals and replacing critical components, regardless of their condition. While this approach represented an improvement over 'reactive' maintenance, it required considerable expense in terms of downtime, labor and materials, especially if the machinery was 'healthy.' This procedure also subjected equipment to the possibility of damage during the repair or reassembly process. This concern was reinforced by studies in the commercial aircraft industry<sup>1</sup> that showed an unusually high correlation between failures and recently performed maintenance work.

In addition to implementing the maintenance program described above, plant personnel routinely monitored the overall vibration level of major pieces of rotating equipment using permanently-installed proximity probes. Vibration analysts used the vibration data from the probes to assess machinery health. Analysis typically visited each plant 2 to 4 times per year to collect data.

Although this practice was seen as a step toward predictive maintenance, it suffered from several shortcomings including;

- Data was acquired infrequently. The intervals between the periodic vibration surveys were too long for good trending.
- Data was incomplete. Proximity probe data offered only a limited window into the total health of the machinery. The proximity probes were particularly ineffective in gathering data on high-frequency phenomena.
- Data management was inefficient. Machine histories were not shared between plants and the lack of standardized measurement procedures made one to one comparisons difficult.
- Manpower resources were not used effectively. Highly trained vibration analysts spent more time traveling between plants than analyzing data.

Vibration analysts decided that the most effective way to eliminate these shortcomings was to implement a system-wide condition monitoring/predictive maintenance program. The goals were:

- Reduce costs and improve profitability by early detection of impending problems.
- Increase the interval between turnarounds
- Share information in a system-wide database which would improve problem analysis, diagnosis and corrective capabilities.

## The Need for High-Frequency Data

An underlying principle of the new system was that the addition of high-frequency measurements to the low-frequency proximity probe data would provide a more complete picture of machinery health. High-frequency vibration is particularly useful in diagnosis and analysis of several classes of problems in high-speed turbomachinery. The most widely-known phenomenon involves the set of signals generated by a pair of meshing gears in a gearbox. A high-frequency accelerometer is the preferred sensor for measuring this important information.

The general guideline for analysis of a gearbox is to look at three harmonics of gear mesh frequencies and their sidebands. The harmonics of gear mesh and the natural frequency of the gears are also important signals. Increases in this group of frequencies are primary indications of a gearing problem, such as gear wear, misalignment, eccentricity or improper backlash<sup>2</sup>. The presence of and changes in these signals are important diagnostic indicators in assessing the cause and cure of gearing problems.

---

<sup>1</sup> Wowk, Victor. *Machinery Vibration: Measurements and Analysis*. McGraw-Hill Inc., 1991.

<sup>2</sup> Bloch, Heinz P., and Geitner, Fred K. *Practical Machinery Management for Process Plants/Volume 2: Machinery Failure Analysis and Troubleshooting*. Gulf Publishing Company, 1983.

Care must be exercised in analyzing gear-related phenomena since many of the signals are highly sensitive to variation in load.

### Frequency Response and Mounting Techniques

Vibration literature had previously explained that the frequency response of an installed accelerometer was highly dependent upon the method used to attach the sensor to the structure. Literature contended that, of the four common methods for attaching sensors to mounting locations in predictive maintenance (stud mounted, adhesive-attached, magnet mounted and hand-held), stud mounting provided the widest frequency response and the most secure and reliable attachment while all other methods reduced the upper frequency range of the sensor. See Figure 1.

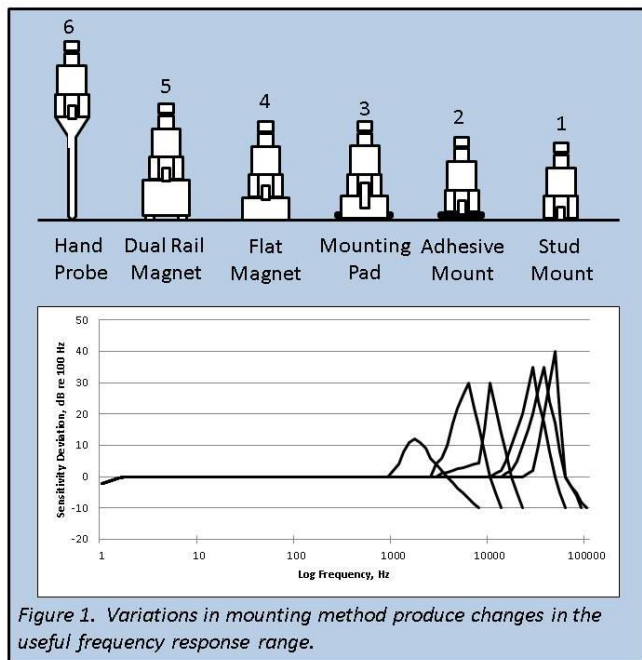

Figure 1. Variations in mounting method produce changes in the useful frequency response range.

At the time, the above creed translated into the following typical rules for mounting of accelerometers:

- Stud mounted sensors give the most accurate readings.
- Wax, glue and a glued target stud are slightly inferior, but the difference can generally be ignored unless the spectra appear noisy.
- Magnet mounts significantly degrade sensor performance. For example, the 20 kHz response of a stud-mounted accelerometer might be expected to reduce to the 3 to 4 kHz range.
- Hand-held transducers are accurate to only 1 kHz or less.

Conventional wisdom maintained that high-frequency data (up to 20 kHz) was best obtained by stud-mounting an appropriate accelerometer. However, a study at the time<sup>3</sup> showed that misapplication could degrade sensor accuracy. Insufficient torque between the mating surfaces (5 in.-lbs instead of the 15 in.-lbs specified in this case) degraded the maximum acceptable frequency of a stud-mounted accelerometer to 33% of the ideal response. If the sensor was finger-tightened (instead of torqued), accurate response declined to 12% of full range. If the accelerometer was loose, performance declined as low as 4% of ideal.

<sup>3</sup> Bowers, S.V., Piety, K.R., and Piety, R.W. "Real World Mounting of Accelerometers for Machinery Monitoring." *Sound and Vibration*, February, 1991

Despite its accuracy under ideal conditions, stud mounting was not a realistic option for a vibration program that demanded measurements at hundreds of points on a monthly basis. The drawbacks were related to the time and labor intensive nature of this technique. To achieve accurate measurements from a stud-mounted accelerometer, the technician would have to perform the following steps:

- Thoroughly clean and lubricate the mating surfaces of the accelerometer and the mounting location.
- Properly screw 2.5 to 3 full turns and properly torque the accelerometer.
- Carefully check the cables and connections for damage due to twisting.

The stud mounting process became extremely tedious when collecting data from hundreds of points. Fatigue and boredom on the part of the technician increased the potential for error and endangered the quality of the data. Without a reliable control in place to assure that the accelerometer was properly installed and the appropriate torque was applied, the validity of the data was questionable.

### **Careful Search for a 'Quick' Solution**

The vibration analysts concluded that their program demanded a quick attach/quick disconnect strategy that provided accurate readings at high frequencies. PCB Piezotronics supported Praxair's interest in quick-mounting accelerometers for high-frequency applications by offering Praxair a variety of sensors for evaluation as well as access to their test facilities. The manufacturer's inventory included low-mass, high-response accelerometers with frequency ranges exceeding 20 kHz when properly installed and rare earth magnets for accelerometer mounting. Despite the general opinion that magnet mounts were useful only in low-frequency applications (below 3 to 4 kHz), Praxair felt it was possible to achieve the desired high-frequency response by:

- Combining a high-response accelerometer with a low-mass, high-strength rare earth magnet.
- Carefully controlling the quality of the metal-to-metal surface between the magnet and the structure.
- Providing a layer of lubricant to act as a coupling medium across the magnet-to-structure interface.

To validate this hypothesis, the investigators ran a series of tests using a PCB Piezotronics accelerometer and rare earth magnet. The pull of this magnet was only 2.5 lb. but the low mass (2.3 grams) of the accelerometer/magnet system resulted in a high resonant frequency when mounted. During each of the three test phases described below, various configurations were evaluated to assess the effect of surface preparation, attachment methodology, target designs, different glues and lubricants. To assure repeatability and uniform results, investigators prepared at least three test samples of each configuration and obtained multiple readings from each sample. As the best configurations emerged from the test process, investigators prepared and retested additional samples to confirm the original results.

- Initial evaluations of attachment methodologies took place at the Praxair Technology Center in Tonawanda, NY. A test coupon (which simulated the machine casing) was stud-mounted to a Brüel & Kjær 4809 shaker and driven by a Hewlett-Packard function generator. Testing took place in both vertical and horizontal orientations, using a stud-mounted accelerometer as a reference. A spectrum analyzer and graphic plotter monitored and recorded transducer output.
- The second round of tests (using similar instrumentation) occurred at the National Institute of Standards and Technology (NIST) traceable test laboratory at PCB Piezotronics in Depew, NY. Figure 2 shows comparison spectra and phase angle plots investigated with a spectrum analyzer and reproduced on an X-Y plotter. The frequency response and phase characteristics of the PCB Piezotronics accelerometer in magnet-mounted and stud-mounted configurations are shown in Figure 3. The upper two plots show stud-mounted readings<sup>4</sup>. There was no phase change and the frequency response curve was up just 2 dB at 20 kHz. The lower two plots show readings from the same accelerometer in a magnet mounting. The phase remained flat and the amplitude response was fundamentally identical to about 10 kHz. Between 10 and 20 kHz, the magnet-

---

<sup>4</sup> Bradbury, Gene and Jowdy, George. Praxair Engineering Design White Paper #2672, "Use of Low-Mass High-Frequency Accelerometers," June, 1991.

mounted curve rose slightly faster than the stud-mounted curve. By 20 kHz, the response was at +4 dB. Comparing the magnet-mount to the stud-mount revealed a relative difference of +2 dB at 20 kHz.

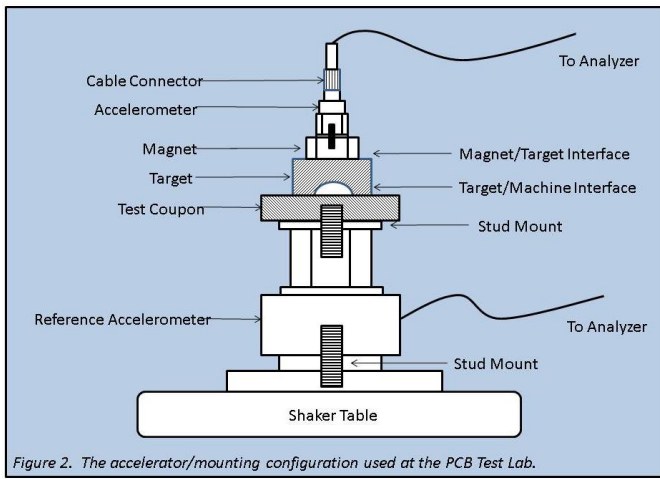

Figure 2. The accelerometer/mounting configuration used at the PCB Test Lab.

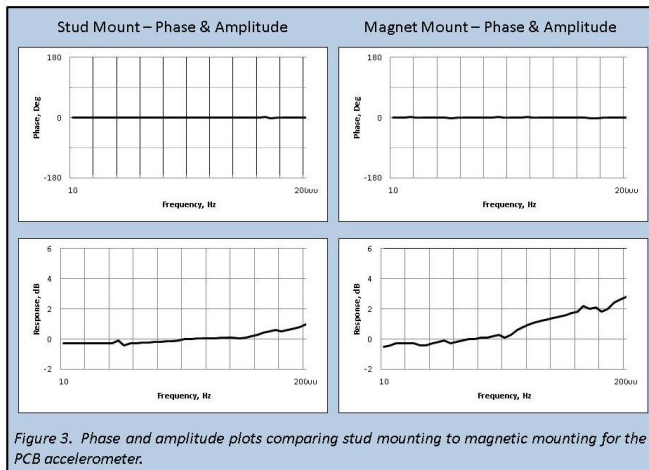
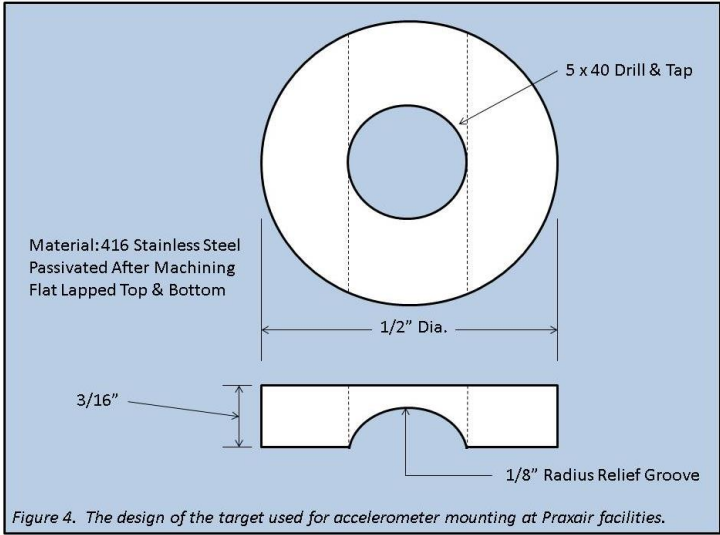

Figure 3. Phase and amplitude plots comparing stud mounting to magnetic mounting for the PCB accelerometer.

- The third set of tests took place on operating machinery at Praxair's air separation facility in Niagara Falls, NY. The accelerometers monitored a variety of equipment, from low-speed induction motors to high-speed gearboxes and centrifugal compressors. A stud-mounted accelerometer again provided reference readings. Investigators made multiple measurements to assure repeatability of transducer configuration,

In addition to revealing the efficiency of magnet mounting, the tests clearly demonstrated the importance of controlling the metal-to-metal surface between the magnet and the structure. Machine surfaces in the real world do not provide the ideal flatness, smoothness, cleanliness and surface finish necessary to achieve high-frequency response with a magnet-mount accelerometer.

There was also concern that repeatability would suffer if the accelerometer was mounted in slightly different locations on successive tests. To overcome these difficulties, investigators decided to permanently mount a small metallic target (see Figure 4) at each measurement point on each machine. The surfaces of the target were machined to a 60 uin finish. The magnet/accelerometer system attached directly to the target. As a result of this target strategy, readings were always taken on an ideal surface at the same point, in exactly the same direction with exactly the same amount of clamping force.



The presence of a lubricant as a coupling medium across the mechanical interface between the magnet and the target proved to be an extremely crucial element of the attachment system. The spectra shown in Figure 5 come from a high speed gearbox. They clearly indicated that identical magnet-mount accelerometer configurations produced significantly different curves with and without grease. Note that the resonance envelope of the dry magnet-mount begins at less than 12 kHz. The greased magnet mount very closely emulated the stud-mounted reference all the way to 20 kHz. The magnet-mounted accelerometer was slightly more sensitive at the high frequencies, as would be expected from the data presented above.

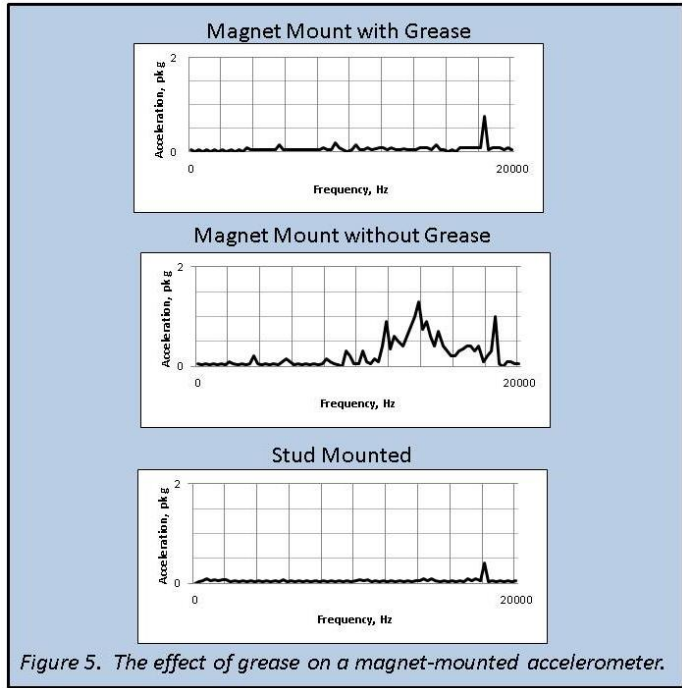

### Implementation of the Program

Resolution of this key technical issue opened the way to implementation. The planners envisioned a network of independent plants sharing support and advanced analysis resources. Each plant would

collect and use its own vibration data and then share the information with the rest of the network through a national database.

To facilitate this strategy, planners provided a uniform framework for vibration monitoring at each plant. A team of vibration analysts and plant maintenance personnel evaluated instrumentation and analysis software. The recommendation of the group defined the universal hardware/software selection for every plant in the network. Measurement points on identical machines at different plant sites were positioned at the same spot and identified with the same name, permitting easy comparison of vibration data. Vibration analysts created a generic template of common machinery types to facilitate construction of uniform databases. The template included frequency bands and alarm limit sets applicable to the wide range of installed equipment.

Each facility chose a vibration 'partner' to champion the program. Since this individual was not a vibration specialist, the tools and procedures for vibration collection had to be straight-forward and easy to use. The transition from the existing state to the desired state took place in phases. Appropriate training and support helped to assure an orderly transition.

### Addendum

While combining a small, low-mass, test-and-measurement style accelerometer with a powerful rare earth magnet, a smooth-clean surface and some silicone grease yielded a previously-unreached, magnetically-mounted frequency response of 20 kHz for walk-around vibration monitoring, Praxair vibration analysts still did not have a solution to meet the high frequency needs of many high speed gearboxes.

A sensor with a maximum frequency of 20 kHz is sufficient for fault analysis of many, if not most, gearboxes where a frequency range of slightly higher than three times gear mesh is required. However, it still falls short on many high speed gearboxes used with turbocompressors. In fact, 20 kHz is not even high enough to measure one time gear mesh in very high-speed cases. As a result, Praxair vibration analysts were looking for a way to extend the frequency response of a magnetically-mounted accelerometer even farther.

In order to meet Praxair's needs, PCB Piezotronics characterized the frequency response of a magnetically-mounted, low-mass, high-frequency accelerometer and designed an internal low pass filter to counteract the resonance in order to raise the mounted resonant frequency of the sensor and thus its flat ( $\pm 3\text{dB}$ ) frequency response. The plot in Figure 6 represents the high-frequency data that was collected on a portable FFT analyzer for this newly-designed accelerometer.

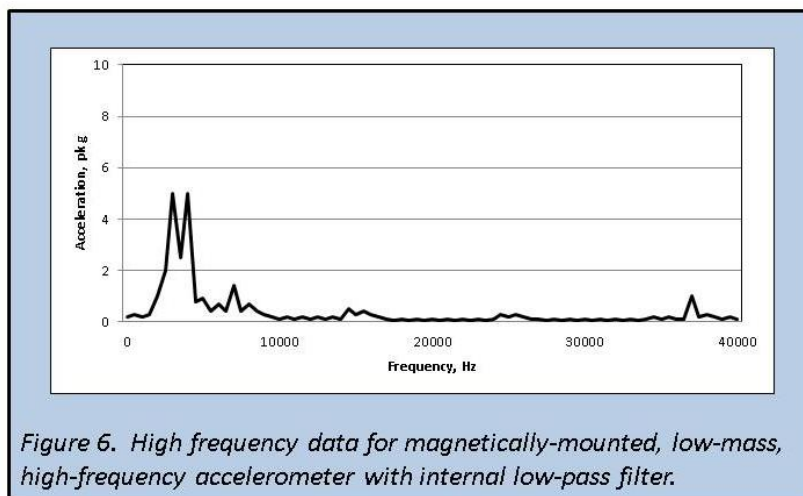

Figure 6. High frequency data for magnetically-mounted, low-mass, high-frequency accelerometer with internal low-pass filter.



The PCB Piezotronics Model 621C40 has a flat frequency response of 30 kHz both stud-mounted (-3 dB) and magnetically-mounted (+3 dB). It should be noted that to reach the magnetically-mounted frequency of 30 kHz, the surface must be clean, flat, and coated with a light coating of silicon grease. This product became the accelerometer of choice for Praxair's high frequency turbocompressor monitoring and continues to be the ideal solution for high frequency measurements to this day.

Since the implementation of the program at hundreds of Praxair plants with many different types of air separation equipment, the magnet-mounting technique has met all requirements for accuracy at high frequencies and ease of use. Benefits of the program have included:

- Reduction in unscheduled downtime. Almost every week, the program identifies a condition that might have caused a plant to go down if not corrected in a timely manner.
- Increase in overall equipment availability. Since the program has been in place, equipment availability at Praxair plants has increased several percentage points.
- More efficient use of plant personnel. At each measurement location, the quick-attach/quick-disconnect mount saves at least a minute over stud-mounting. Multiply this by hundreds of measurement points at hundreds of plants every month. The result is a very considerable savings of manpower over the course of a year.
- More efficient use of vibration resources. Because the program runs smoothly, vibration analysts are able to spend their time resolving critical problems or doing proactive work to make the entire network more efficient.



**3425 Walden Avenue, Depew, NY 14043 USA**

**pcb.com/imi-sensors | imi@pcb.com | 800 959 4464 | +1 716 684 0003**

© 2021 PCB Piezotronics - all rights reserved. PCB Piezotronics is a wholly-owned subsidiary of Amphenol Corporation. Endevo is an assumed name of PCB Piezotronics of North Carolina, Inc., which is a wholly-owned subsidiary of PCB Piezotronics, Inc. Accumetrics, Inc. and The Modal Shop, Inc. are wholly-owned subsidiaries of PCB Piezotronics, Inc. IMI Sensors and Larson Davis are Divisions of PCB Piezotronics, Inc. Except for any third party marks for which attribution is provided herein, the company names and product names used in this document may be the registered trademarks or unregistered trademarks of PCB Piezotronics, Inc., PCB Piezotronics of North Carolina, Inc. (d/b/a Endevo), The Modal Shop, Inc. or Accumetrics, Inc. Detailed trademark ownership information is available at [www.pcb.com/trademarkownership](http://www.pcb.com/trademarkownership).

WPL\_46\_1121