

# Torque Sensors

Written By  
Kenneth Watkins

## Torque Sensors

### An Overview of their Design and Application

#### Principle of Operation

All torque sensors manufactured by PCB Load & Torque, Inc are strain gage based measuring instruments whose output voltage is proportional to applied torque. The output voltage produced by a resistance change in strain gages that are bonded to the torque sensor structure. The magnitude of the resistance change is proportional to the deformation of the torque sensor and therefore the applied torque.

The four-arm Wheatstone Bridge configuration shown below depicts the strain gage geometry used in the torque sensor structures. This configuration allows for temperature compensation and cancellation of signals caused by forces not directly applied about the axis of the applied torque.

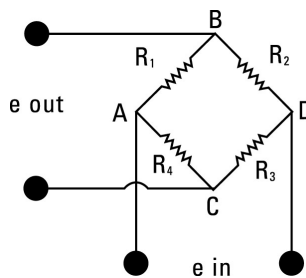

A regulated 5 to 20 volt DC or AC RMS excitation is required and is applied between points A and D of the Wheatstone Bridge. When torque is applied to the transducer structure the Wheatstone Bridge becomes unbalanced, thereby causing an output voltage between points B and C. This voltage is proportional to the applied torque.

PCB Load & Torque, Inc. Series 2300 reaction torque sensors have the following wiring code:

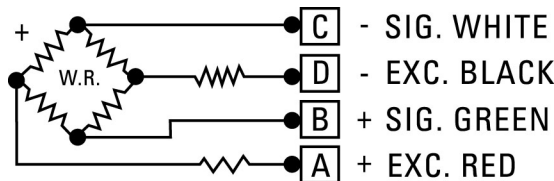

PCB Load & Torque, Inc Series 4100 rotary transformer torque sensors have the following wiring code:

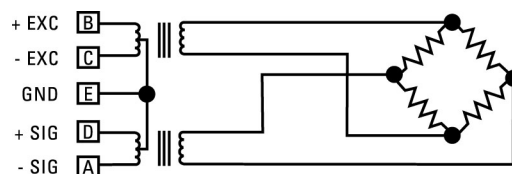

PCB Load & Torque, Inc Series 4200 rotary transformer torque sensors have the following wiring code:

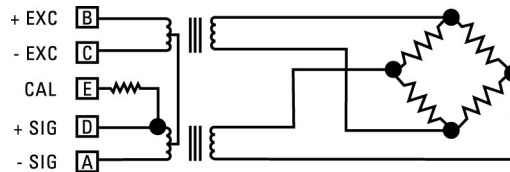

### Axis Definition

All PCB Load & Torque, Inc. torque sensors comply with the Axis and Sense Definitions of NAS-938 (National Aerospace Standard-Machine Axis and Motion) nomenclature and recommendations of the Western Regional Strain Gage committee.

The axes are defined in terms of a “Right Handed” orthogonal coordinate system as show below:

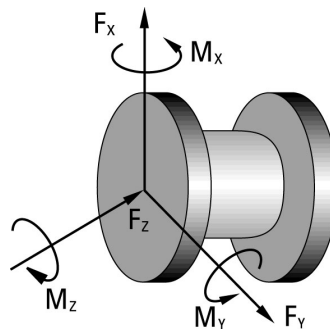

A “+” sign indicates force in a direction that produces a “+” signal voltage and generally defines a clockwise torque.

The principal axis of a transducer is normally the z-axis. The z-axis will also be the axis of radial symmetry or axis of rotation. In the event there is no clearly defined axis, the following preference system will be used z, x, y. The following illustration shows the axis and sense nomenclature for PCB Load & Torque, Inc. torque sensors:

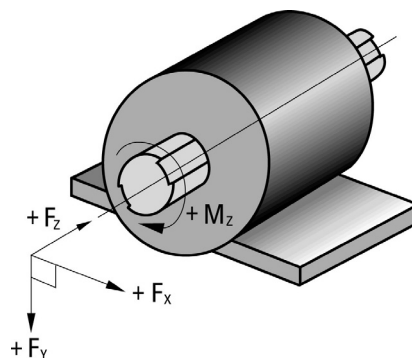

### Torque Sensor Structure Design

Torque sensor structures are symmetrical and typically manufactured from steel (SAE 4140 or 4340) that has been heat-treated to Rc 36 to 38. Common configurations are solid circular shaft, hollow circular shaft, cruciform, hollow cruciform, solid square, and hollow tube with flats.

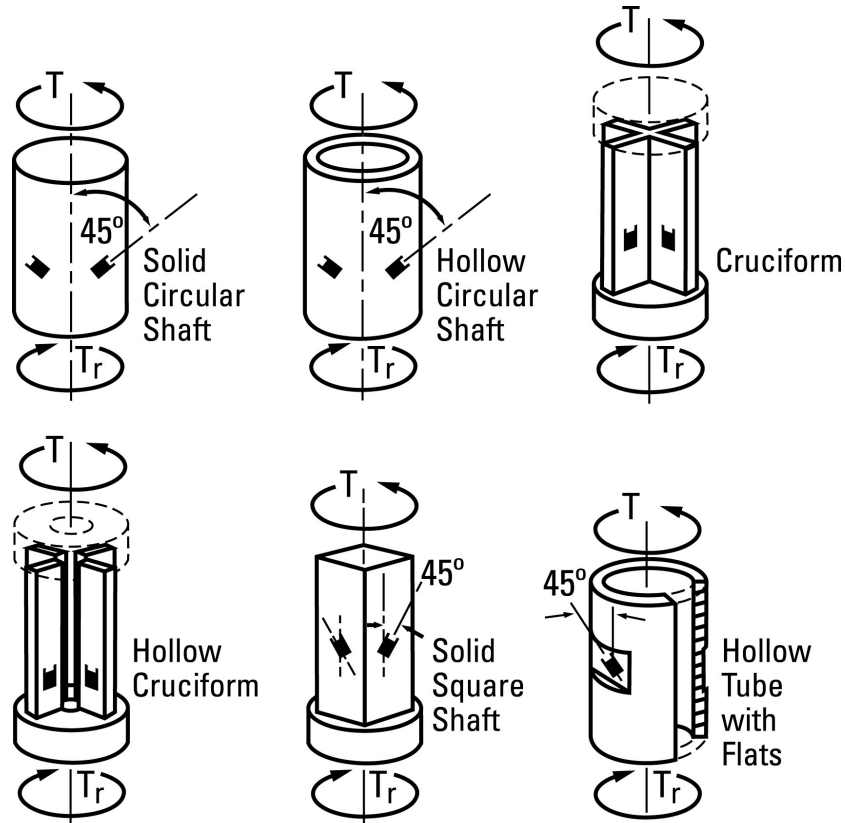

The solid square offers advantages over the solid circular design, especially in capacities greater than or equal to 500 in-lb. The solid square offers high bending strength and ease of application of strain gages. Torque sensors with capacities less than 500 in-lb are usually of the hollow cruciform type. The hollow cruciform structure produces high stress at low levels of torque, yet has good bending strength.

A variety of end configurations are available, including: keyed shaft, flange, and spline.



Keyed Shaft



Flange Drive



Spline Drive

**PCB LOAD & TORQUE, INC.**

24350 Indoplex Circle, Farmington Hills, MI 48335 USA  
Phone: 866-684-7107 Fax: 716-684-0987 Email: [ltinfo@pcbloadtorque.com](mailto:ltinfo@pcbloadtorque.com) [www.pcbloadtorque.com](http://www.pcbloadtorque.com)

ISO 9001:2015 QMS Certified by DQS, Inc. A2LA Accredited to ISO 17025

## Reaction Torque Sensors

Typical reaction torque sensor applications are listed below.

- Viscosity and Lubrication Studies
- Bearing Friction
- Stepping Switch Torque
- Axle Torsion Test
- Starter Testing
- Automotive Brake Testing

Reaction torque is the turning force or moment, imposed upon the stationary portion of a device by the rotating portion, as power is delivered or absorbed. The power may be transmitted from rotating member to stationary member by various means, such as the magnetic field of a motor or generator, brake shoes or pads on drums or rotors, or the lubricant between a bearing and a shaft. Thus, reaction torque sensors become useful tools for measuring properties such as motor power, braking effectiveness, lubrication, and viscosity.

Reaction torque sensors are suitable for a wide range of torque measurement applications including motor and pump testing. Due to the fact that these sensors do not utilize bearings, slip rings, or any other rotating elements, their installation and use can be very cost effective. Reaction torque sensors are particularly useful in applications where the introduction of a rotating mass between the driver and driven is undesirable. An example of this can be found in small motor testing, where introduction of a rotating mass between the motor and load device will result in an error during acceleration. For these applications, the reaction torque sensor can be used between the drive, or driven, and ground. An added benefit is that such an installation is not limited in RPM by the torque sensor. PCB Load & Torque, Inc. manufactures reaction torque sensors with capacities ranging from a few inch ounces to 500,000 inch pounds, in configurations including keyed shaft and flange.

## Rotary Torque Sensors

Typical rotary torque sensor applications are listed below.

- Chassis Dynamometer
- Engine Dynamometer
- Efficiency Testing
- Clutch Testing
- Blower or Fan Testing
- Small Motor / Pump Testing

Rotating torque sensors are similar in design and application with the exception that the torque sensor is installed inline with the device under test. Consequently, the torque sensor shaft rotates with the device under test. In PCB Load & Torque, Inc. Series 3100, 4100, and 4200, the rotating torque sensor shaft is supported in a stationary housing by two bearings. Signal transfer between the rotating torque sensor shaft and the stationary housing is accomplished by means of slip rings, or rotary transformer.

### Rotary Transformers

Rotary Transformers provide a non-contact means of transferring signals to and from the rotating torque sensor structure. Rotary transformers are similar to conventional transformers except that either the primary or secondary winding is rotating. For rotating torque sensors, two rotary transformers are used. One serves to transmit the excitation voltage to the strain gage bridge, while the second transfers the signal output to the non-rotating part of the transducer. Thus no direct contact is required between the stationary and rotating elements of the transducer.

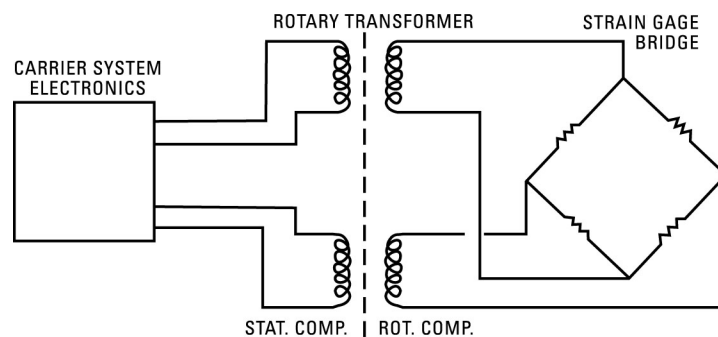

Rotary transformers are made up of a pair of concentrically wound coils, with one coil rotating within or beside the stationary coil. A time varying voltage (carrier excitation) is applied to one of the coils producing magnetic flux line. The diagram below depicts a rotary transformer torque sensor.

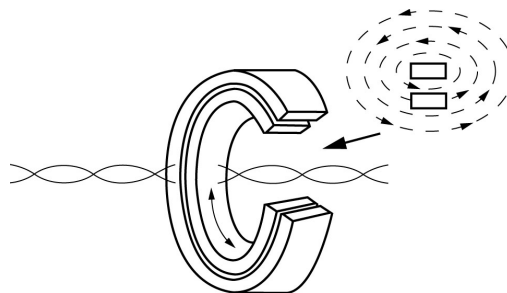

Transmission of energy through any transformer requires that the current be alternating. A suitable signal conditioner with carrier excitation in the range of 3000 to 5000 Hz is required.

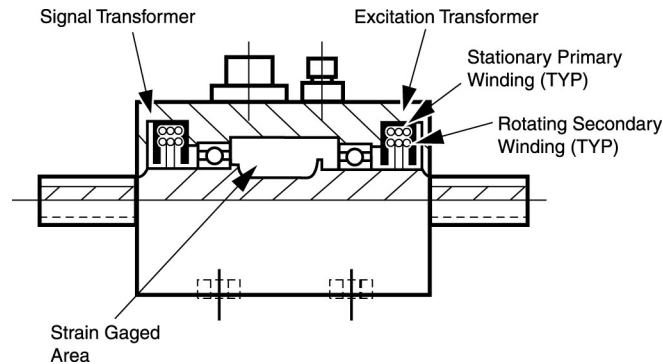

### Mechanical Installation of Keyed Shaft Torque Sensors

Proper installation must be observed when assembling a torque sensor into a driveline. Careful selection of components must be made so that problems are not created which could lead to part failure or danger to personnel.

#### Shaft Misalignment

Provision must be made to eliminate the effects of bending and end loading on the torque sensors shaft due to parallel offset of shafts, angular misalignment, and shaft end float. The proper use of couplings can reduce these problems to a negligible level.

All shafts must first be aligned mechanically, as accurately as possible, to lessen the work of the couplings. Alignment within 0.001" per inch of shaft diameter is normally satisfactory, however, for some critical applications such as high speed, this level of alignment is not acceptable and a tighter tolerance must be achieved. Contact PCB Load & Torque, Inc. for information regarding specific applications.

#### Torque Sensor with Foot Mounted Housing Installation

A foot mounted torque sensor has a plate on its housing which can be securely attached to a machine base or bed-plate. This installation reduces the mass in suspension on the couplings and can increase the shafts critical speed, if the torque sensor is within its speed rating. Normally, if both the driving and load sources are fully bearing supported in foot-mounted housings, and the torque sensor housing is foot mounted, double-flex couplings should be used on each shaft end. Double-flex couplings provide for two degrees of freedom, meaning they can simultaneously allow for angular and parallel misalignment and reduce the effects of bending on the torque sensor shaft. Half of each coupling weight is supported on the torque sensors shaft while the driving and load shafts carry the other half.

## **Torque Sensor with Floating Shaft Installation**

A floating shaft torque sensor does not have a foot mount plate on the housing, nor is the housing affixed to a bedplate in any other fashion, it depends on being carried by the driver and load shafts. The housing, which is meant to remain stationary and not rotate with the shaft, must be restrained from rotating with a conductive flexible strap. Tapped threaded holes are provided on the side of the housing for this purpose. The other end of the strap is bolted to a bedplate or other stationary-grounded member, which will electrically ground the torque sensor housing to the electrical system ground.

Therefore, with the floating shaft, there is just one degree of freedom between each shaft end of the torque sensor and the adjacent mating shaft, which is bearing supported (driver and load shafts) on the bedplate. Consequently, a single flex coupling is required at each end of the torque sensor.

## **Error Analysis**

PCB Load & Torque, Inc. typically supplies accuracy information on its products in the form individual errors. They are Non-Linearity, Hysteresis, Non-Repeatability, Effect of Temperature on Zero Unbalance, and Effect of Temperature on Output.

The customer can combine these individual errors to establish the maximum possible error for the measurement or just examine the applicable individual error. If the temperature remains stable during the test, the temperature related errors can be ignored. If the sensor is used for increasing load measurement only, the Hysteresis error can be ignored. If the load measurement is near the full capacity, the linearity error can be ignored. If the capability exists to correct the data through linearization-fit or a look-up-table, the error in the measurement can be minimized. A sophisticated user can get rid of all the errors except for the non-repeatability error in the measurement.

Often overlooked is the error due to the presence of non-measured forces and bending moments. Even though the Single Axis of Measurement sensors are designed and built to withstand these non-measured forces and bending moments (extraneous loads), the errors due to them are present. The Measurement Engineer can design the set-up to eliminate or minimize these extraneous loads. However, if these extraneous loads are present, the errors due to them should be considered.



## Application Questionnaire

### 1. Determine the capacity required

- A. What is the maximum expected torque, including transients?
- B. What is the minimum expected torque?
- C. What is the typical expected torque?
- D. What are the dynamics of the system, i.e., frequency response?
- E. What are the maximum extraneous loads that the torque sensor will be subjected to?

### 2. How will the torque sensor be integrated into the system?

- A. What are the physical constraints, i.e., length, diameter
- B. Will the torque sensor be foot mounted or floated?
- C. Couplings, torsionally stiff or torsionally soft?

### 3. What type of environment will the torque sensor be operating in?

- A. Maximum temperature?
- B. Minimum temperature?
- C. Humidity?
- D. Contaminants, i.e., water, oil, dirt, dust?

### 4. What speed will the torque sensor be required to rotate?

- A. What length of time will the torque sensor be rotating and at what speed?



**3425 Walden Avenue, Depew, NY 14043 USA**

pcb.com | info@pcb.com | 800 828 8840 | +1 716 684 0001

© 2022 PCB Piezotronics - all rights reserved. PCB Piezotronics is a wholly-owned subsidiary of Amphenol Corporation. Endevo is an assumed name of PCB Piezotronics of North Carolina, Inc., which is a wholly-owned subsidiary of PCB Piezotronics, Inc. Accumetrics, Inc. and The Modal Shop, Inc. are wholly-owned subsidiaries of PCB Piezotronics, Inc. IMI Sensors and Larson Davis are Divisions of PCB Piezotronics, Inc. Except for any third party marks for which attribution is provided herein, the company names and product names used in this document may be the registered trademarks or unregistered trademarks of PCB Piezotronics, Inc., PCB Piezotronics of North Carolina, Inc. (d/b/a Endevo), The Modal Shop, Inc. or Accumetrics, Inc. Detailed trademark ownership information is available at [www.pcb.com/trademarkownership](http://www.pcb.com/trademarkownership).

WPL\_25\_0922