



**TN-18**

# **Introduction to Air Blast Measurements - Part III**

**Guaranteeing That Validated Pressure Measurements Are Acquired**

Written By

Patrick L. Walter, Ph. D.

# Introduction to Air Blast Measurements

## Part III: Guaranteeing that Validated Pressure Measurements are Acquired

Patrick L. Walter, Ph. D

Measurement Specialist, PCB Piezotronics, Inc.  
Depew, NY 14043

Engineering Faculty, Texas Christian University  
Fort Worth, TX 76129

Parts I and II of this series provided a brief background on blast pressure phenomenology and its measurement. They also described how coupling the pressure transducer to the blast environment could influence the response of the measurement system. The current part introduces the concept of data validation.

In addition to pressure, which is the desired environment to be measured, there are competing undesired environments that occur concurrent with the pressure environment. These include, as a minimum: transient temperature, light, acceleration, strain, ionization products of the detonation, and others. When considering the potential effects of these undesired environments, it can be seen that strain, acceleration and temperature can all interact with the piezoelectric crystal within the transducer to result in an erroneous pressure indication. In addition, thermoelectric, photoelectric, electromagnetic, triboelectric, and other energy induced effects can result in additive electrical signals that create errors in the transducer output. All of these extraneous signals can be viewed as noise, which contaminates the desired pressure measurement. To validate that the transducer output signal is not contaminated (i.e., it is solely attributable to pressure), a combination of placebo<sup>3</sup> and “check”<sup>4</sup> channels must be used.

If one looks at the piezoelectric d-coefficients of quartz, they appear as:

$$\begin{aligned} P_{XX} &= d_{11}\sigma_{XX} - d_{11}\sigma_{YY} + 0\sigma_{ZZ} + d_{14}\tau_{YZ} + 0\tau_{ZX} + 0\tau_{XY} \\ P_{YY} &= 0\sigma_{XX} + 0\sigma_{YY} + 0\sigma_{ZZ} + 0\tau_{YZ} - d_{14}\tau_{ZX} - 2d_{11}\tau_{XY} \\ P_{ZZ} &= 0\sigma_{XX} + 0\sigma_{YY} + 0\sigma_{ZZ} + 0\tau_{YZ} + 0\tau_{ZX} + 0\tau_{XY} \end{aligned} \quad (3)$$

These equations show that there is one crystal axis of quartz (z-axis, 3<sup>rd</sup> equation) that produces no piezoelectric output when stress is applied. Figure 10 contains a boule of quartz

with this axis (z) identified. It is possible to manufacture a placebo blast transducer, i.e., one that produces no piezoelectric output, using z-cut quartz.

The placebo transducer can be applied in the test in the same manner as any of the operational transducers, but it will not respond to mechanical inputs (pressure, acceleration, strain). Any electrical output from it identifies signal contamination due to thermoelectric, photoelectric, electromagnetic, and / or triboelectric effects. In reality, a signal from the placebo transducer is typically caused by electrical or magnetic noise induced effects and indicates that the operational transducers are probably also similarly contaminated. Triboelectric (i.e., frictionally generated) charge effects in cables can be ruled out as a noise source if integral electronics (ICP<sup>®</sup>) are included within or at the transducer. This is because, as noted previously, ICP<sup>®</sup> converts the transducer to an equivalent low-impedance voltage source. Just as an electrical signal from a placebo transducer indicates signal contamination, no electrical signal from it indicates the effects responsible for the contamination to be absent.

Light intensity should also have no influence on the transducers discussed to date. Thermal effects will subsequently be discussed as a separate topic.

It remains yet to determine whether strain and / or acceleration result in additional contamination of the signal from the pressure transducer. Strain and acceleration have a cause / effect relationship. For example, under pressure induced acceleration loading, flexural modes of vibration might be excited in a plate in which a blast pressure transducer is mounted. The plate's motion elicits an acceleration response from the transducer by inducing stress in the piezoelectric element of the transducer, as does the resultant strain.

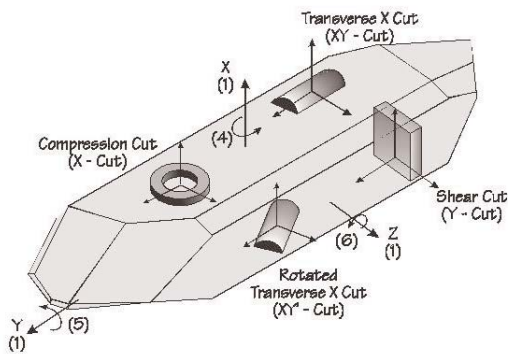

**Figure 10: Quartz Boule With Linear and Rotational Axes Directions Identified**

To identify the combined effect of acceleration and strain on the piezoelectric element, we take an operational transducer and isolate it from the desired pressure environment. It becomes a “check” channel. The right-hand portion of Figure 11 (see back page) shows the field application of a “check” transducer. An operational transducer is mounted per the manufacturer’s specifications in a hole dimensioned deep enough to prevent the transducer from making contact. If necessary, a small weep-hole can be drilled into the hole from the back surface of the plate to assure that no pressure build-up occurs due to flexing under pressure loads of the material in front of the transducer diaphragm. Any signal output from the check channel in excess of that produced by the placebo transducer is noise induced by strain and / or acceleration.

Under no circumstances can the undesired response from either the placebo transducer or “check” channel be “subtracted” from the signal of the pressure measuring transducer(s) as a data correction scheme. This is because the undesired environments contained in the pressure transducer(s) signals are spatially distributed across the test item. Thus, phasing errors would occur. The next several paragraphs, up to and including Figure 11, outline the process(es) and analysis that must be undertaken in order to replicate the effect of the “subtraction” if it could legitimately occur.



**Figure 4: PCB Blast Pressure Transducer, Series 134 Blast Probe**

The combination of the placebo transducer and “check” transducer allows us to document almost all of the aforementioned undesired responses with the noted exception of thermal effects due to transient temperature. The Model 134 Blast Probe (Figure 4) is principally used to define the fast-rise-time shock front. Due to the acoustic wave-guide principle on which the probe operates, a thin layer of black tape on its front face is required to mitigate thermal inputs to its very thin tourmaline crystal. This transducer is not intended to record the entire pressure-time history of the blast pulse. Adding additional tape at the probe’s front boundary will provide greater thermal delay, but will also result in increased mechanical impedance, which degrades performance. Thus, its application is limited to short record times. Longer record times, such as those required for the total pressure impulse, necessitate a transducer with a mechanical configuration like that shown in Figure 5 (in an earlier article). Fortunately, a transducer made like that in Figure 5, produces a very recognizable signature when a transient thermal input creates a problem. A thermal transient initially couples into and causes various dimensional changes followed by expansion of the preload sleeve containing the quartz crystal assembly. The byproduct of this later expansion shows up as a negative (i.e., nonreturn to zero) signal residing after the blast event is clearly over.

Every manufacturer’s transducers will respond to these undesired environments. However, some respond much less than others. The question is: “How do you manage or mitigate these responses?” Limited examples follow.

Thermal transient responses must be mitigated by application of ceramic or RTV coatings on the face of the transducer diaphragm. These provide a thermal delay, hopefully until the blast event is over. Reference 5 provides one such quantitative study of time delays that are achievable.

Figure 11 (left side) shows how a strain-induced signal can be eliminated as a noise source through mechanical isolation, in this case, via a concentric groove machined around the transducer to interrupt the strain transmission path. Low-density foam can be used to fill this groove to prevent a discontinuity to the flow of the blast products.

Previously, Figure 5 showed how essentially building an accelerometer within the pressure transducer, if its output is added in opposition to the acceleration response of the pressure-sensing element, could minimize acceleration effects. If the acceleration-compensation mass is further adjusted, the sensor’s frequency response is also enhanced. This is called “frequency tailoring.”

Elimination of those noise-induced signals uniquely identified by the placebo transducer would likely occur through attention to proper grounding and shielding. It should be noted that electrostatic shielding materials (e.g., copper, aluminum) are very poor electromagnetic shielding materials.

As can be seen, once documented, the various undesired responses require individual noise-reduction solutions. After additional tests in which both the placebo and “check” transducers produce no output, the pressure signals on the other data channels can be considered validated. That is, all the recorded data can now be considered to be the appropriate response of the pressure transducer(s) to the pressure environment alone.

**References:**

3. Shock and Vibration Transducer Selection, Institute of Environmental Sciences and Technology, IEST RP-DTE011.1, Sec. 7.9, Oct. 2002.
4. Stein, P. K., The Unified Approach to the Engineering of Measurement Systems, Stein Engineering Services, Phoenix, AZ, April 1992.
5. Hilten, John, Vezzetti, Carol, Mayo-Wells, J. Franklin, Lederer, Paul, Experimental Investigation of Means for Reducing the Response of Pressure Transducers to Thermal Transients, NBS Tech Note 961, January 1978.



**Figure 11: Strain Isolated Pressure Transducer Left – Isolated “Check” Transducer Right**

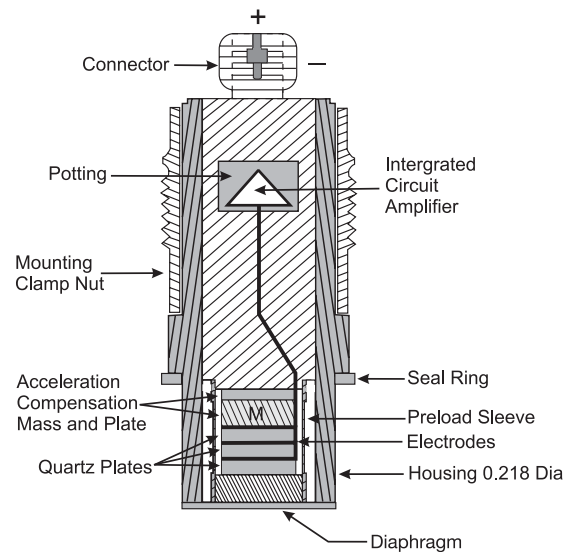

**Figure 5: ICP® Acceleration Compensated Pressure Transducer**

(Please refer to PCB Tech Notes 12 and 13 for full text of Parts I and II of the “Introduction to Air Blast Measurements” Series)



**3425 Walden Avenue, Depew, NY 14043 USA**

pcb.com | info@pcb.com | 800 828 8840 | +1 716 684 0001

© 2022 PCB Piezotronics - all rights reserved. PCB Piezotronics is a wholly-owned subsidiary of Amphenol Corporation. Endevo is an assumed name of PCB Piezotronics of North Carolina, Inc., which is a wholly-owned subsidiary of PCB Piezotronics, Inc. Accumetrics, Inc. and The Modal Shop, Inc. are wholly-owned subsidiaries of PCB Piezotronics, Inc. IMI Sensors and Larson Davis are Divisions of PCB Piezotronics, Inc. Except for any third party marks for which attribution is provided herein, the company names and product names used in this document may be the registered trademarks or unregistered trademarks of PCB Piezotronics, Inc., PCB Piezotronics of North Carolina, Inc. (d/b/a Endevo), The Modal Shop, Inc. or Accumetrics, Inc. Detailed trademark ownership information is available at [www.pcb.com/trademarkownership](http://www.pcb.com/trademarkownership).