

TN-15

Dynamic Pressure Calibration

Written By

Jim Lally, Co-founder PCB Piezotronics, Inc.

Dan Cumiskey, Pressure Division Manager PCB Piezotronics, Inc.

DYNAMIC PRESSURE CALIBRATION

Jim Lally & Dan Cummiskey

Co-founder Pressure Division Manager

PCB Piezotronics, Inc. Depew, NY 14043 USA

Background

In the late 1950's and 1960's, with the advent of the aerospace era and advanced weapons development, came the requirement for high-frequency pressure sensors to make shock wave, blast, rocket combustion instability, and ballistic measurements. Piezoelectric sensors at that time had limited frequency response, and were mainly used for acoustic and engine combustion applications.

It was during this period that Walter Kistler, working closely with Abe Hertzberg at the former Cornell Aeronautical Labs in Buffalo, NY, developed miniature, high-frequency acceleration-compensated quartz pressure sensors with microsecond response time. This research spearheaded the development of shock tube technology, critical for researching aerodynamic shock waves that a spacecraft might encounter during re-entry. Other research facilities developed special sensors tailored to specific applications. At Aberdeen Proving Ground, Ben Granath designed blast pressure sensors for weapons development and a unique, tourmaline-structured, non-resonant pressure bar for reflected shock wave measurements. Pat Walter, then an engineer at Sandia National Laboratories, provided invaluable feedback on these early sensor designs.

Need for Dynamic Calibration

Along with the development of higher frequency sensors came the need for dynamic pressure calibration. Since dynamic calibrators were not commercially available until relatively recently, many labs developed unique calibration devices to suit specific needs. These included a variety of hydraulic and pneumatic shock, pulse, and sine wave pressure generators. The dead weight tester was sometimes used in a pressure release mode to generate a known, negative pressure pulse. The calibration shock tube remains the most practical device for producing the fastest rise time over a wide range of pressures, although the pressure amplitude is not known as accurately as with pulse calibrators.

Piezoelectric Sensor Characteristics

Piezoelectric (PE) pressure transducers are well-suited for dynamic pressure measurements. They are available in high-impedance charge output and, more commonly, Integrated Circuit Piezoelectric (ICP®) designs. They are fabricated from natural piezoelectric quartz, natural tourmaline, or artificially polarized, manmade ferroelectric ceramics. PE sensors operate over a wide temperature range and have a wide linear dynamic range, ultra high-frequency response, and rise times as fast as 0.2 μ S. They are small, have flush diaphragms, and provide a clean, high-voltage output. A single quartz sensor may be used accurately in ranges of

0 to 10 psi, 0 to 1000 psi, or any level in between. With durable, solid-state construction, they are ideal for use in harsh environments. They are uniquely suited for low-pressure fluid borne noise measurements under high static pressure.

There is a general misperception that because PE sensors are "...dependent on changes of strain to generate electrical charge, they are not useable with DC or steady state conditions" (ref. 1). This is not entirely correct for all PE sensors. It is true that ceramic structured sensors do not respond to steady state conditions, and that they do require dynamic calibration. However, quartz charge output sensors have very high insulation resistance of $>10^{12}$ ohms. When used with electrostatic charge amplifiers, quartz sensors exhibit short-term static response and can be calibrated by conventional static dead weight methods. ICP® pressure sensors might require dynamic calibration, depending on discharge time constant (low frequency), which is fixed within the sensor. Test results on the same quartz sensor, calibrated by five different methods over a wide range of amplitudes and frequencies, indicate that its sensitivity is virtually independent of the method used (see Figure 1).

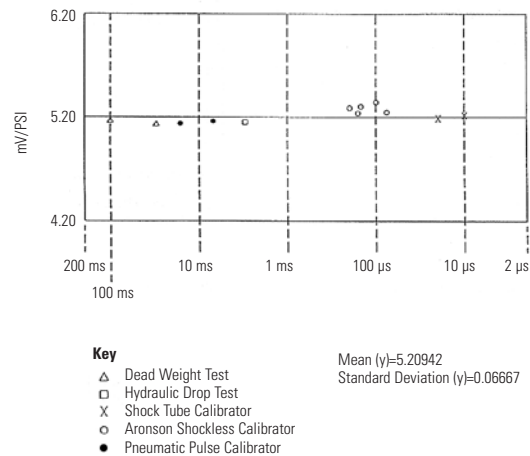

Figure 1: PCB's Model 113A24 quartz pressure sensor exhibits consistent sensitivity when calibrated by five different methods, over a wide frequency range, at amplitudes from 100 to 1000 psi.

Dynamic Calibration Methodology

Methodology for dynamic pressure transducer calibration is more demanding and less accurate than static dead weight methods, where measurement data can be carried out to many decimal points. Dynamic pressure calibration is generally accomplished by

venting the sensor being calibrated to a known static reference pressure, by means of a fast-acting valve; by hydraulic impulse comparison calibration, using a transfer standard; or with the shock tube. Depending on the type of calibrator and gas medium used, rise times in the order of microseconds or milliseconds can be achieved. Sensor mounting, switching transients, and readout accuracy are all factors. Digital signal processing has greatly improved measurement accuracy compared to earlier methods that used analog storage oscilloscopes. The "ideal" dynamic calibrator would be structured to generate a precisely known reference pressure that can be continuously adjusted over a wide range of amplitudes and frequencies. However, a device like this does not exist.

Traceability to National Standards

As is the case with all calibration methods, dynamic calibration should be traceable to a nationally accredited laboratory, such as the National Institute of Standards & Technology (NIST). However, the authors are not aware of any national labs that provide "traceable" dynamic pressure calibration. In 1991, NIST held a workshop that focused on transient pressure and temperature. Technical presentations involved both current and proposed dynamic calibration methodologies.

NIST-traceable dynamic pressure sensor calibration can be achieved by pressurizing a chamber with an accurately known static pressure, as measured with a NIST-traceable DC reference gage, and quickly venting the sensor to be calibrated to this known pressure. Signal conditioning and readout instruments would be NIST-traceable through electrical calibration. Other methods involve sine or pulse comparison calibration, using a transfer standard with NIST-traceable calibration.

In the early 1970's, a group of scientists, sensor users, and manufacturers formed a working group to develop, for ANSI, *A Guide for the Dynamic Calibration of Pressure Transducers*. This document has been updated and published by the Instrumentation Society of America (ISA) (ISA document 37.16.01.2002).

Why Use Dynamic Calibration?

Dynamic pressure calibration is useful for several reasons. With ceramic structured sensors, it is the only way to determine sensor output relative to input. Some DC low-frequency sensors may not respond the same to identical static or dynamic input pressure. The output of all pressure sensors is frequency dependent. Dynamic calibration devices, such as the shock tube, are quite useful for determining sensor resonance characteristics, as well as resonance in gas passages associated with recessed mounting. Gas passage resonance is analogous to the frequency response change resulting from the addition of an adaptor between an accelerometer base and test structure.

Development of Dynamic Pressure Calibrators

Dynamic pressure calibrators have evolved over the years in response to specific needs at various laboratories. Calibrators vary widely in the type of pressure source used, and in their amplitude and frequency range. PCB® adapted the best of these technologies for in-house sensor research and dynamic calibration. To help customers understand and evaluate the characteristics of sensors for transient applications, several dynamic pressure calibrators are now offered as standard commercial products.

Dynamic pressure calibrators are of two general types, periodic and aperiodic. The periodic types, such as a Pistonphone, generate a defined sine wave pressure for calibration of microphones and other low-pressure acoustic sensors. Aperiodic calibrators generate a single pulse. The hydraulic piston and cylinder impulse calibrator, developed at Sandia in the 1960's, is one of the more versatile dynamic calibrators, with capability to calibrate over a wide pressure range.

Some aperiodic calibrators use an accurate DC pressure gauge to set a known static pressure in a chamber and then rapidly switch the test sensor to this pressure using a fast-acting valve. One such device is the Aronson calibrator, which incorporates a poppet-type switching valve. It was developed by Phil Aronson at the Naval Ordnance Laboratory to calibrate underwater pressure sensors at incremental pressures under higher static load conditions.

Of the different pressure switching mechanisms, poppet valves provide the fastest response, usually in the 50 to 100 μ S range. Solenoid valves are generally not well-suited, as they tend to produce an oscillating pressure source during the switching process. In pneumatically operated calibrators, the use of helium will provide the fastest rise time.

Hydraulic Impulse Calibrator

This versatile aperiodic calibrator is structured with a free-falling mass dropped onto a piston and cylinder manifold to create a hydraulic pulse with a 3 mS rise time and 6 mS duration (see Figure 2). A linear tourmaline transfer standard, installed in the manifold, measures pulse amplitude, which is then compared with the sensor being calibrated to establish its input/output sensitivity. The drop calibrator has the capability of generating pressures from ~ 100 to 20,000 psi, depending on the height from where the mass is dropped.

A high-pressure version of the drop calibrator, PCB Model 913A10, operates from 10,000 to 125,000 psi. This unit uses an accelerometer to measure deceleration of the free-falling mass after it strikes the piston. Deceleration of the mass, coupled with the geometries of the piston and cylinder, determines pressure pulse amplitude. The Model 913A10 structure is less complex and it is easier to operate, compared to other high-pressure dynamic calibrators.

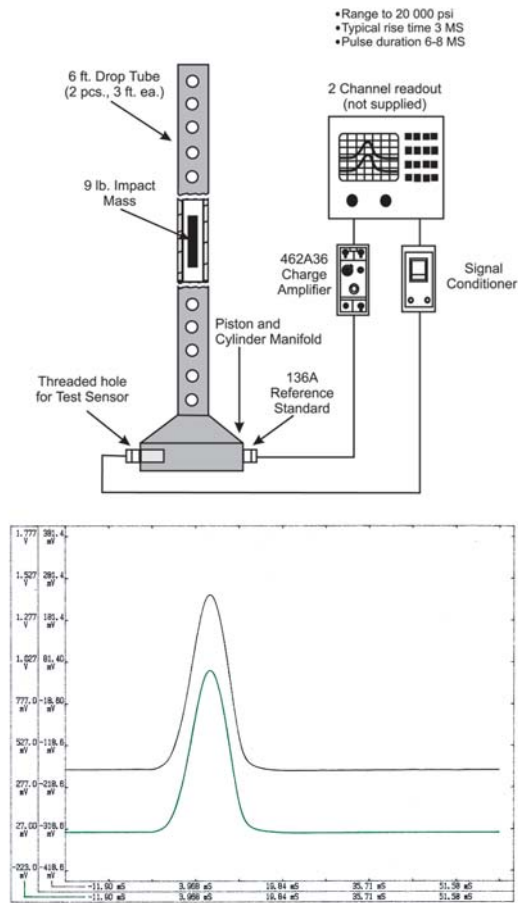

Figure 2:

PCB Model 913B02 impulse calibrator uses a free-falling mass that strikes a piston and cylinder manifold to produce a pulse waveform for pressure sensor calibration over a wide dynamic range. Calibration is performed by comparing outputs from the test and reference sensors, both installed in the manifold and subjected to the same pressure pulse. Pressure amplitude is determined by the height from which the mass is dropped.

Calibration Shock Tube

PCB Model 901A10 is a gas-driven shock tube, capable of producing shock waves with nanoseconds of rise time (see Figure 3). Depending on the diaphragm material separating the driver from the test section, shock waves as low as 3 psi can be generated using aluminum foil, and >1000 psi using sheet aluminum. Compressed gas, such as air, helium, or nitrogen, is pressurized in the driver section until the diaphragm bursts, sending a shock wave into the test section. As a driver source, helium provides a well-formed shock wave with the highest Mach number. Amplitude accuracy of the shock wave (approx. 1.5%) is calculated from measurement of the shock wave velocity and atmospheric pressure.

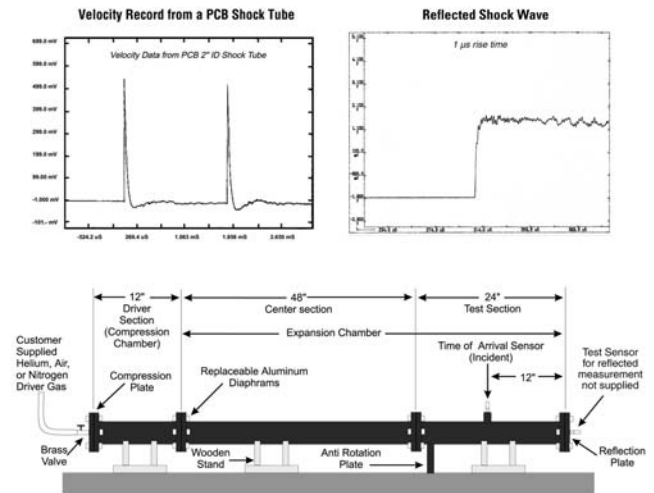

Figure 3:

PCB Model 901A10 shock tube is useful for calibrating and testing the dynamic behavior of high-frequency pressure sensors. Shock wave amplitude is calculated by measuring shock wave velocity, temperature, and barometric pressure. Pressure amplitude is determined by selection of the diaphragm material and thickness used in the driver section. Reflected shock waves, occurring at the end wall, will excite the resonance of most pressure sensors. This location is also used for testing the resonant characteristics of gas passages in front of recess-mounted sensors.

Aronson Step Pressure Generator

The step pressure generator (see Figure 4) was developed by Phil Aronson and R. Wasser at the Naval Ordnance Lab in the 1960's, to calibrate underwater pressure sensors at incremental pressures under high static loads. Phil dedicated much of his professional career to the study of transient pressure measurements and dynamic calibration. Their goal was to develop an aperiodic calibration device, capable of performing dynamic calibration with greater accuracy and ease than was possible with the shock tube. The device, using helium as a gas source, is capable of generating known step pressures up to 2000 psi in ~ 50 µS.

The concept and operation of the Aronson Step Pressure Generator is quite fundamental. It involves rapidly venting a precisely known static pressure to a sensor diaphragm by pressurizing the main reservoir with a known static pressure, then quickly exposing the sensor being calibrated to the reference pressure by releasing the fast-acting poppet valve. The pressure drop in the main reservoir due to the added volume between the sensor diaphragm and poppet valve is negligible with flush diaphragm sensors, and would be indicated on the digital pressure gauge that monitors reservoir pressure. The step pressure generator can be used to produce positive or negative pressure pulses of accurately known amplitude. NIST-traceability is through the DC reference gauges used to set the known static pressure level to which the test sensor will be rapidly exposed.

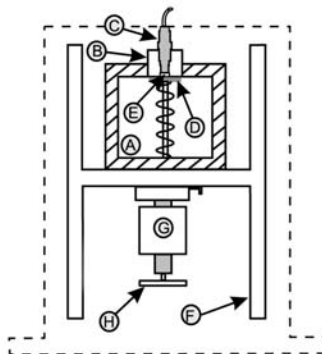

A - pressure reservoir
 B - gage adaptor plug
 C - pressure sensor
 D - poppet valve
 E - poppet volume
 F - housing - support system
 G - impact weight
 H - impact plate

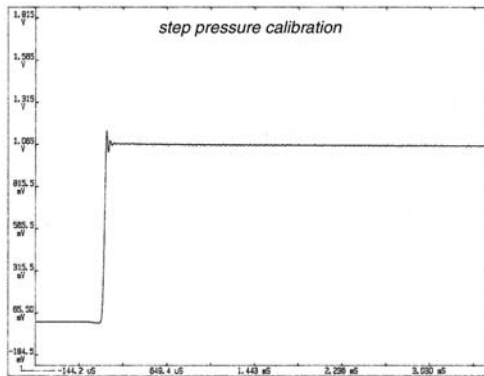

Figure 4:

This step pressure calibrator generates an accurately known step pressure using a fast-acting poppet valve. This type of aperiodic calibrator is easier to operate and provides more accurate calibration than the shock tube, but does not operate at so high a frequency.

“Pistonphone” Microphone Calibrator

The Pistonphone (see Figure 5) is a good example of a periodic calibrator. The portable, battery powered device produces a fixed 134 dB amplitude sine wave at a frequency of 250 Hz for calibration of microphones and low-pressure acoustic sensors. The known sine wave reference pressure level is generated by two opposed reciprocating pistons, in a controlled volume inside the Pistonphone. The use of precision mounting adaptors is critical for maintaining known volume and reference pressure when calibrating different types of sensors.

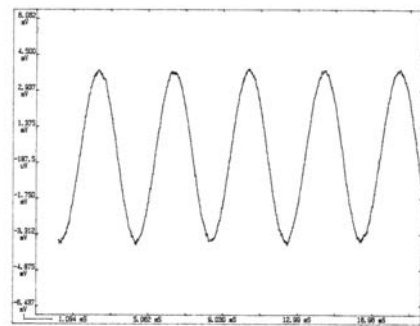

Figure 5:

Microphones and acoustic pressure sensors are commonly calibrated with a Pistonphone, which generates an accurately known sine wave pressure at a fixed frequency.

Summary

Several different types of high and low-pressure calibrators are commercially available to assist the engineer with dynamic calibration and evaluation of frequency response associated with sensor recess mounting. Calibrators vary in the amplitude, frequency, and type of the waveform generated. As a general guide, the calibration methodology used should most closely approximate the measurement application in which the sensor is to be used.

Reference:

- 1.) Jon S. Wilson, January 2003, “Pressure Measurement: Principles and Practices”, *Sensors*, Vol. 20, No. 1:25



3425 Walden Avenue, Depew, NY 14043 USA

pcb.com | info@pcb.com | 800 828 8840 | +1 716 684 0001

© 2022 PCB Piezotronics - all rights reserved. PCB Piezotronics is a wholly-owned subsidiary of Amphenol Corporation. Endevo is an assumed name of PCB Piezotronics of North Carolina, Inc., which is a wholly-owned subsidiary of PCB Piezotronics, Inc. Accumetrics, Inc. and The Modal Shop, Inc. are wholly-owned subsidiaries of PCB Piezotronics, Inc. IMI Sensors and Larson Davis are Divisions of PCB Piezotronics, Inc. Except for any third party marks for which attribution is provided herein, the company names and product names used in this document may be the registered trademarks or unregistered trademarks of PCB Piezotronics, Inc., PCB Piezotronics of North Carolina, Inc. (d/b/a Endevo), The Modal Shop, Inc. or Accumetrics, Inc. Detailed trademark ownership information is available at www.pcb.com/trademarkownership.