



# General Signal Conditioning Guide



# GENERAL SIGNAL CONDITIONING GUIDE

## INTRODUCTION

---

<b>1</b>	<b>Introduction</b> .....	4
<b>2</b>	<b>Conventional Charge Output Sensors</b> .....	4
2.1	Voltage Mode and Voltage Amplified Systems.....	4
2.2	Charge Amplified Systems.....	6
<b>3</b>	<b>ICP® Sensors</b> .....	6
3.1	In-line Charge and Voltage Amplifiers.....	8
3.2	Powering ICP® Systems.....	8
3.3	Effect of Excitation Voltage on the Dynamic Range of ICP® Sensors.....	9
<b>4</b>	<b>Installation, General</b> .....	10
<b>5</b>	<b>Operation</b> .....	10
5.1	Apparent Output Drift When AC-coupled.....	11
<b>6</b>	<b>High Frequency Response of ICP® Sensors</b> .....	11
6.1	Mechanical Considerations.....	11
6.2	Amplifier/Power Supply Limitations.....	12
6.3	Cable Considerations and Constant Current Level.....	12
6.4	Experimentally Testing Long Cables.....	14
<b>7</b>	<b>Low Frequency Response of ICP® Sensors</b> .....	14
7.1	Transducer Discharge Time Constant.....	15
7.1.1	Effect of DTC on Low Frequency Response.....	16
7.1.2	Effect of DTC on Long Duration Time Waveforms.....	16
7.2	Effect of Coupling on Low Frequency Response.....	17
<b>8</b>	<b>Methods of DC Coupling</b> .....	17
<b>9</b>	<b>Cautions</b> .....	18

# 1 INTRODUCTION

Recent developments in state-of-the-art integrated circuit technology have made possible great advances in piezoelectric sensor instrumentation. The intent of this guide is to enhance the usefulness of today's advanced sensor concepts by acquainting the user with the advantages, limitations and basic theory of sensor signal conditioning.

This educational guide will deal with the following types of basic sensor instrumentation:

- 1 Charge Output Sensors** — high output impedance, piezoelectric sensors (without built-in electronics) which typically require external charge or voltage amplifiers for signal conditioning.
- 2 Internally Amplified Sensors** — low impedance, piezoelectric force, acceleration and pressure-type sensors with built-in, integrated circuits. (ICP<sup>®</sup> is a registered trademark of PCB Group, Inc., which uniquely identifies

PCB<sup>®</sup> sensors incorporating built-in electronics.)

## 2 CONVENTIONAL CHARGE OUTPUT SENSORS

Historically, nearly all dynamic measurement applications utilized piezoelectric charge output sensors. These sensors contain only a piezoelectric sensing element (without built-in electronics) and have a high impedance output signal.

The main advantage of charge output sensors is their ability to operate under high temperature environments. Certain sensors have the ability to withstand temperatures exceeding +1000 °F (+538 °C). However, the output generated by piezoelectric sensing crystals is extremely sensitive to corruption from various environmental factors. Low-noise cabling must be used to reduce radio frequency interference (RFI) and electromagnetic interference (EMI.) The use of tie wraps or tape reduces triboelectric (motion-induced) noise. A high insulation resistance of the sensor and cabling should be maintained to avoid drift and ensure repeatable results.

To properly analyze the signal from charge output sensors, the high impedance output must normally be converted to a low impedance voltage signal. This can be done directly by the input of the readout device or by in-line voltage and charge amplifiers. Each case will be considered separately.

### 2.1 VOLTAGE MODE (AND VOLTAGE AMPLIFIED) SYSTEMS

Certain piezoelectric sensors exhibit exceptionally high values of internal source capacitance and can be plugged directly into high impedance (>1 Megohm) readout devices such as oscilloscopes and analyzers. Others with a low internal source capacitance may require in-line signal conditioning such as a voltage amplifier. See Figure 1.

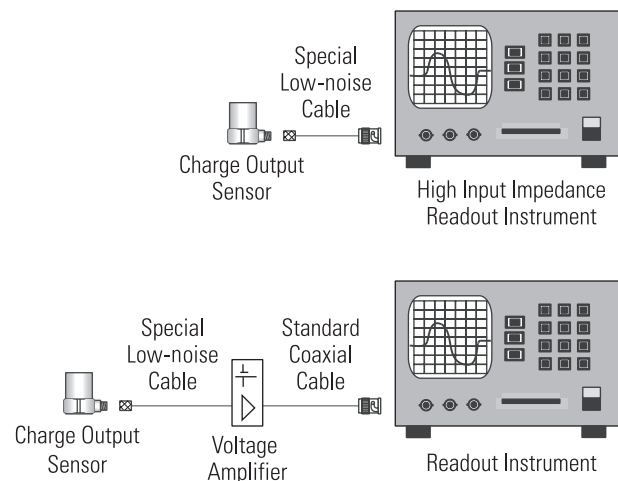

Figure 1. Typical Voltage Mode Systems

A schematic representation of these voltage mode systems including sensor, cable and input capacitance of voltage amplifier or readout device is shown below in Figure 2. The insulation resistance (resistance between signal and ground) is assumed to be large (>10<sup>12</sup> ohms) and is therefore not shown in the schematic.

The open circuit (e.g., cable disconnected) voltage sensitivity V<sub>1</sub> (Volts per psi, lb or g) of the charge output sensor can be represented mathematically by Equation 1.

$$V_1 = q / C_1 \quad \text{(Equation 1)}$$

where: q = basic charge sensitivity in pC per psi, lb or g

C<sub>1</sub> = Internal sensor (crystal) capacitance in pF

(p = pico = 1 x 10<sup>-12</sup>; F = farad)

The overall system voltage sensitivity measured at the readout instrument (or input stage of the voltage amplifier) is the reduced value shown in Equation 2.

$$V_2 = q / (C_1 + C_2 + C_3) \quad \text{(Equation 2)}$$

where: C<sub>2</sub> = cable capacitance in pF

C<sub>3</sub> = input capacitance of the voltage amplifier or

readout instrument in pF

According to the law of electrostatics (Equations 1 and 2), sensing elements with a low capacitance will have a high voltage sensitivity. This explains why low-capacitance quartz sensors are used predominantly in voltage systems.

This dependency of system voltage sensitivity upon the total system capacitance severely restricts sensor output cable length. It explains why the voltage mode sensitivity of high impedance-type piezoelectric sensors is measured and specified with a given cable capacitance. If the cable length and/or type is changed, the system must be recalibrated. These formulas also show the importance of keeping the sensor input cable/connector dry and clean. Any change in the total capacitance or loss in insulation resistance due to contamination can radically alter the system characteristics. Furthermore, the high-impedance output signal makes the use of low-noise coaxial cable mandatory and precludes the use of such systems in moist or dirty environments, unless extensive measures are taken to seal cables and connectors.

From a performance aspect, voltage mode systems are capable of linear operation at high frequencies. Certain sensors have frequency limits exceeding 1 MHz, making them useful for detecting shock waves with a fraction of a microsecond rise time. However, care must be taken, as large capacitive cable loads may act as a filter and reduce this upper operating frequency range.

Unfortunately, many voltage amplified systems have a noise floor (resolution) which may be an order of magnitude higher than equivalent charge amplified systems. For this reason, high-resolution ICP<sup>®</sup>, and/or charge amplified sensors, are typically used for low-amplitude dynamic measurements.

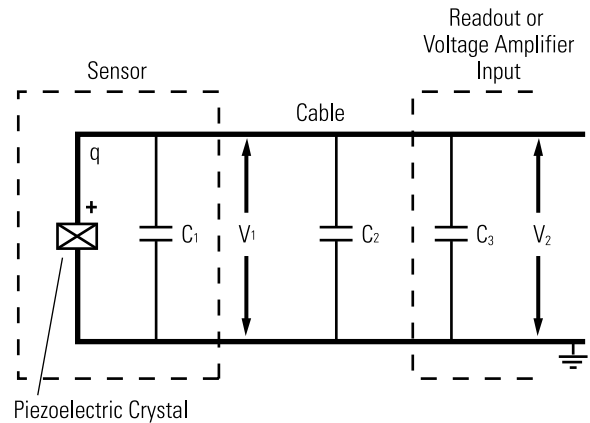

**Figure 2. Voltage Mode System Schematic**

## 2.2 CHARGE AMPLIFIED SYSTEMS

A typical charge amplified measurement system is shown below in Figure 3.

A schematic representation of a charge amplified system, including sensor, cable and charge amplifier, is shown in Figure 4. Once again, the insulation resistance (resistance between signal and ground) is assumed to be large (>1012 ohms) and is therefore not shown in the schematic.

In this system, the output voltage is dependent only upon the ratio of the input charge,  $q$ , to the feedback capacitor,  $C_f$ , as shown in Equation 3. For this reason, artificially polarized polycrystalline ceramics, which exhibit a high charge output, are used in such systems.

$$V_{out} = q / C_f \quad (\text{Equation 3})$$

There are serious limitations with the use of conventional charge amplified systems, especially in field environments or when driving long cables between the sensor and amplifier. First, the electrical noise at the output of a charge amplifier is directly related to the ratio of total system capacitance

$(C_1 + C_2 + C_3)$  to the feedback capacitance ( $C_f$ ). Because of this, cable length should be limited, as was the case in the voltage mode system. Secondly, because the sensor output signal is of a high impedance type, special low-noise cabling must be used to reduce charge generated by cable motion (triboelectric effect) and noise caused by excessive RFI and EMI.

Also, care must be exercised to avoid degradation of insulation resistance at the input of the charge amplifier to avoid the potential for signal drift. This often precludes the use of such systems in harsh or dirty environments, unless extensive measures are taken to seal all cables and connectors.

While many of the performance characteristics are advantageous as compared to voltage mode systems, the per-channel cost of charge amplified instrumentation is typically very high. It is also impractical to use charge amplified systems above 50 or 100 kHz, as the feedback capacitor exhibits filtering characteristics above this range.

## 3 ICP® SENSORS

ICP® is a term that uniquely identifies PCB's piezoelectric sensors with built-in microelectronic amplifiers. (ICP® is a registered trademark of PCB Group, Inc.) Powered by constant current signal conditioners, the result is an easy-to-operate, low-impedance, two-wire system as shown in Figure 5.

In addition to ease-of-use and simplicity of operation, ICP® sensors offer many advantages over traditional charge output sensors, including:

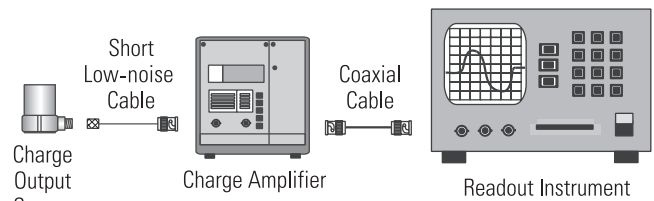

Figure 3. Typical Charge Amplified System

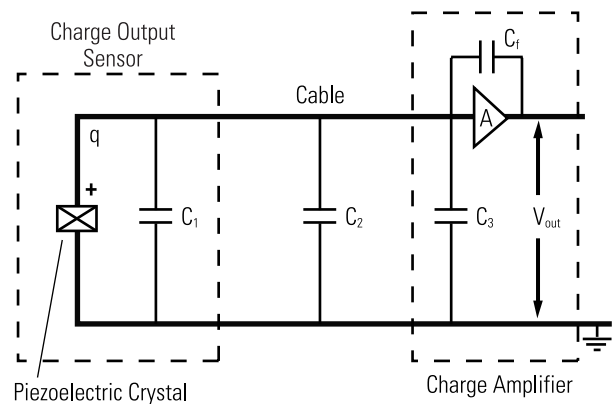
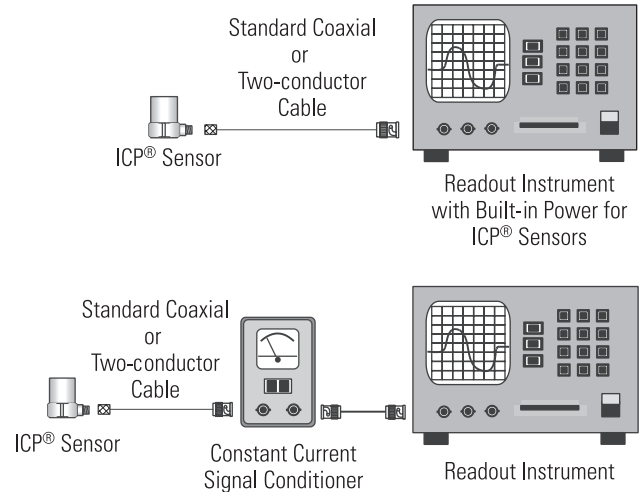

Figure 4. Charge Amplified System Schematic

- 1 Fixed voltage sensitivity, independent of cable length or capacitance.
- 2 Low output impedance (<100 ohms) allows signals to be transmitted over long cables through harsh environments with virtually no loss in signal quality.
- 3 Two-wire system accommodates standard low-cost coaxial or other two-conductor cables.
- 4 High quality, voltage output, compatible with standard readout, recording or acquisition instruments.
- 5 Intrinsic sensor self-test feature by monitoring sensor output bias voltage.
- 6 Low per-channel cost as sensors require only low-cost, constant current signal conditioners and ordinary cables.
- 7 Reduced system maintenance.
- 8 Direct operation into readout and data acquisition instruments, which incorporate power for use with PCB's ICP® sensors.

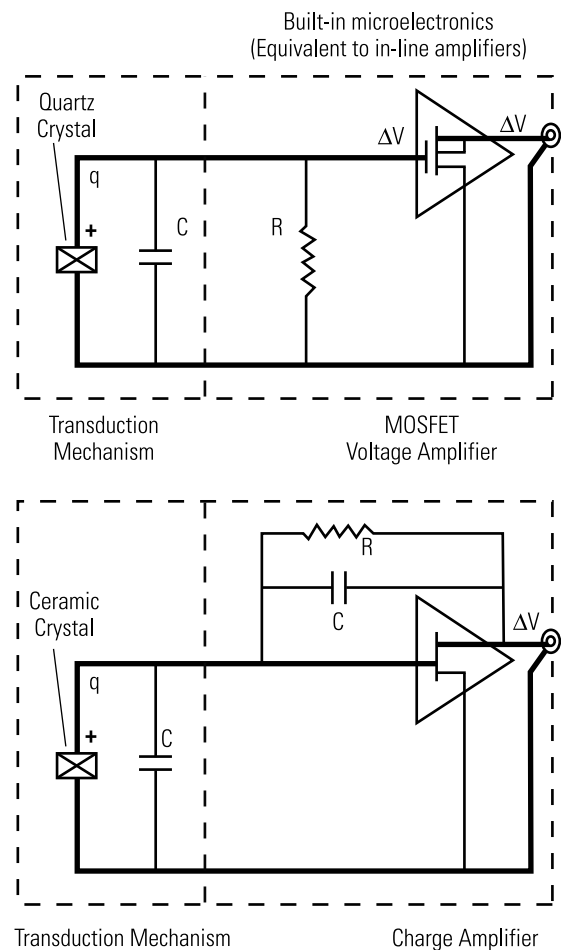

**Figure 5. Typical ICP® Sensor Systems**

Figure 6 schematically shows the electrical fundamentals of typical quartz and ceramic ICP® sensors. These sensors are comprised of a basic piezoelectric transduction mechanism (which has an output proportional to force, pressure acceleration, or strain, depending on the sensor type) coupled to a highly reliable integrated circuit.

Two types of integrated circuits are generally used in ICP® sensors: voltage amplifiers and charge amplifiers. Low capacitance quartz sensing elements exhibit a very high voltage output (according to  $V = q/C$ ) and are typically used with MOSFET voltage amplifiers. Ceramic sensing elements which exhibit a very high charge output are normally coupled to charge amplifiers.

The theory behind ICP® quartz sensing technology will first be explained. The process begins when a measurand, acting upon the piezoelectric sensing element, produces a quantity of charge referred to as  $\Delta q$ . This charge collects in the crystal capacitance,  $C$ , and forms a voltage according to the law of electrostatics:  $\Delta V = \Delta q/C$ . Because quartz exhibits a very low capacitance, the result is a high-voltage output, suitable for use with voltage amplifiers. The gain of the amplifier then determines the sensor sensitivity.



**Figure 6. Basic Quartz and Ceramic ICP® Sensors**

This  $\Delta V$  instantaneously appears at the output of the voltage amplifier, added to an approximate +10 VDC bias level. This bias level is constant and results from the electrical properties of the amplifier itself. (Normally, the bias level is removed by an external signal conditioner before analyzing any data. This concept will be fully explained later.) Also, the impedance level at the output of the sensor is less than 100 ohms. This makes it easy to drive long cables through harsh environments with virtually no loss in signal quality.

ICP<sup>®</sup> sensors which utilize ceramic sensing elements generally operate in a different manner. Instead of using the voltage generated across the crystal, ceramic ICP<sup>®</sup> sensors operate with charge amplifiers. In this case, the high-charge output from the ceramic crystal is the desirable characteristic.

The sensor's electrical characteristics are analogous to those described previously in charge mode systems, where the voltage output is simply the charge generated by the crystal divided by the value of the feedback capacitor. (The gain of the amplifier (mV/pC) ultimately determines the final sensitivity of the sensor). In this case, many of the limitations have been eliminated. That is, all of the high-impedance circuitry is protected within a rugged, hermetic housing. Concerns or problems with contamination and low-noise cabling are eliminated.

A quick comparison of integrated circuit voltage and charge amplifiers is provided below:

Voltage Amplifier	Charge Amplifier
High Frequency (>1 MHz)	Limited Frequency (~100 kHz)
Low-cost	More Costly
Non-inverting	Inverting
Typically used with Quartz	Typically used with Ceramic
Small Size	Low-noise

Note that the schemata in Figure 6 also contain an additional resistor. In both cases, the resistor is used to set the discharge time constant of the RC (resistor-capacitor) circuit. This will be further explained in Section 7.1.

### 3.1 IN-LINE CHARGE AND VOLTAGE AMPLIFIERS

Certain applications (such as high temperature testing) may require integrated circuits to be removed from the sensor. For this reason, a variety of in-line charge amplifiers and in-line voltage amplifiers are available. Operation is identical to that of an ICP<sup>®</sup> sensor, except that the cable connecting the sensor to amplifier carries a high-impedance signal. Special precautions, like those discussed earlier in the charge and voltage mode sections, must be taken to ensure reliable and repeatable data.

### 3.2 POWERING ICP<sup>®</sup> SYSTEMS

A typical sensing system including a quartz ICP<sup>®</sup> sensor, ordinary two-conductor cable and basic constant current signal conditioner is shown in Figure 7. All ICP<sup>®</sup> sensors require a constant current power source for proper operation. The simplicity and the principle of two-wire operation can be clearly seen.

The signal conditioner consists of a well-regulated 18 to 30 VDC source (battery or line-powered), a current-regulating diode (or equivalent constant current circuit), and a capacitor for decoupling (removing the bias voltage) the signal. The voltmeter (VM) monitors the sensor bias voltage (normally 8 to 14 VDC) and is useful for checking sensor operation and detecting open or shorted cables and connections.



The current-regulating diode is used instead of a resistor for several reasons. The very high dynamic resistance of the diode yields a source follower gain which is extremely close to unity and independent of input voltage. Also, the diode can be changed to supply higher currents for driving long cable lengths. Constant current diodes, as shown in Figure 8, are used in all of PCB's battery powered signal conditioners. (The correct orientation of the diode within the circuit is critical for proper operation.) Except for special models, standard ICP® sensors require a minimum of 2 mA for proper operation.

Present technology limits this diode type to 4 mA maximum rating; however, several diodes can be placed in parallel for higher current levels. All PCB line-powered signal conditioners use higher capacity (up to 20 mA) constant current circuits in place of the diodes, but the principle of operation is identical.

Decoupling of the data signal occurs at the output stage of the signal conditioner. The 10 to 30 µF capacitor shifts the signal level to essentially eliminate the sensor bias voltage. The result is a drift-free AC mode of operation. Optional DC coupled models eliminate the bias voltage by use of a DC voltage level shifter.

### 3.3 EFFECT OF EXCITATION VOLTAGE ON THE DYNAMIC RANGE OF ICP® SENSORS

The specified excitation voltage for all standard ICP® sensors and amplifiers is generally within the range of 18 to 30 volts. The effect of this range is shown in Figure 9.

To explain the chart, the following values will be assumed:

- VB = Sensor Bias Voltage = 10 VDC
- VS1 = Supply Voltage 1 = 24 VDC
- VE1 = Excitation Voltage 1 = VS1 - 1 = 23 VDC
- VS2 = Supply Voltage 2 = 18 VDC
- VE2 = Excitation Voltage 2 = VS2 - 1 = 17 VDC
- Maximum Sensor Amplifier Range = ± 10 volts

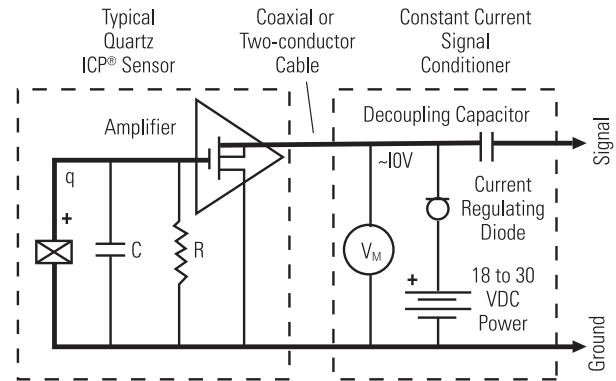

Figure 7. Typical ICP® Sensor System

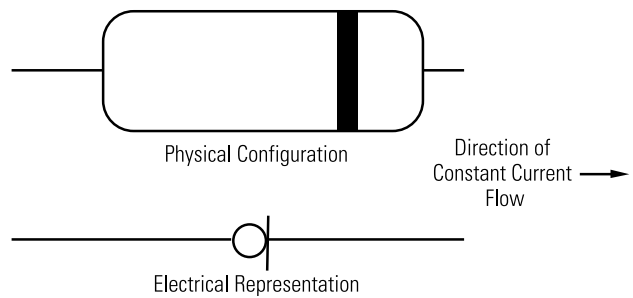

Figure 8. Constant Current Diode

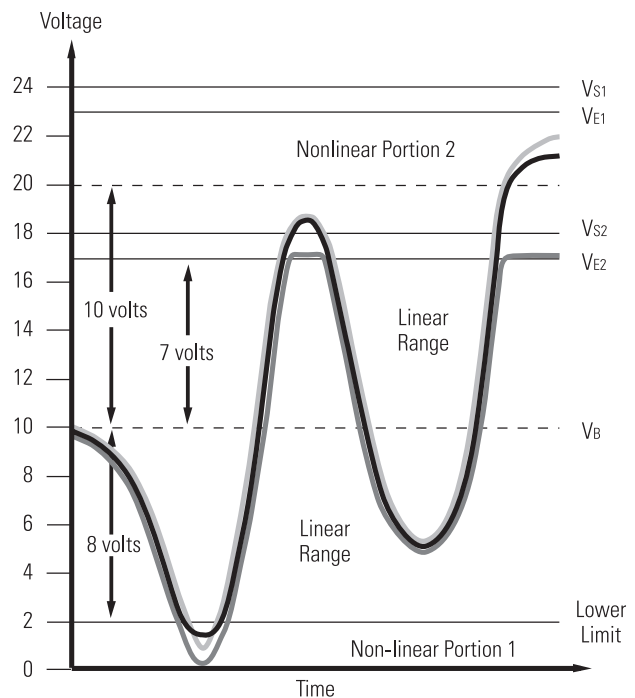

Figure 9.   
 — Input Measurand (signal)   
 - - - Output Signal (18 VDC supply)   
 — Output Signal (24 VDC supply)

Note that an approximate 1-Volt drop across the current limiting diode (or equivalent circuit) must be maintained for correct current regulation. This is important, as two 12 VDC batteries in series will have a supply voltage of 24 VDC, but will only have a 23 VDC usable sensor excitation level.

The solid curve represents the input to the internal electronics of a typical ICP® sensor, while shaded curves represent the output signals for two different supply voltages.

In the negative direction, the voltage swing is typically limited by a 2 VDC lower limit. Below this level, the output becomes nonlinear (nonlinear portion 1 on graph). The output range in the negative direction can be calculated by:

$$\text{Negative Range} = V_B - 2 \quad (\text{Equation 4})$$

This shows that the negative voltage swing is affected only by the sensor bias voltage. For this case the negative voltage range is 8 volts.

In the positive direction, the voltage swing is limited by the excitation voltage. The output range in the positive direction can be calculated by:

$$\text{Positive Range} = (V_S - 1) - V_B = V_E - V_B \quad (\text{Equation 5})$$

For a supply voltage of 18 VDC, this results in a dynamic output range in the positive direction of 7 volts. Input voltages beyond this point simply result in a clipped waveform as shown.

For the supply voltage of 24 VDC, the theoretical output range in the positive direction is 13 volts. However, the microelectronics in ICP® sensors are seldom capable of providing accurate results at this level. (The assumed maximum voltage swing for this example is 10 volts.) Most are specified to ±3, ±5 or ±10 volts. Above the specified level, the amplifier is nonlinear (nonlinear portion 2 on graph). For this example, the 24 VDC supply voltage extended the usable sensor output range to +10/-8 volts.

## 4 INSTALLATION, GENERAL

Please refer to the installation and/or outline drawing included in the sensor manual for mounting preparation and installation techniques. Select desired operating mode (AC or DC coupling) and make sure that cable connectors are tight to provide reliable ground returns. If solder connector adaptors are used, inspect solder joints. If vibration is present, use cable tie-downs, appropriately spaced to avoid cable fatigue. Although ICP® instruments are low-impedance devices, in extreme environments it is advisable to use shielded cables and protect cable connections with heat shrink tubing. Complete installation instructions are provided with each sensor.

## 5 OPERATION

If a PCB® signal conditioner is being used, turn the power on and observe the voltmeter (or LEDs) on the front panel.

Typical indicators are marked as shown in Figure 10. The green area (or LED) indicates the proper bias range for the ICP® sensor and the correct cable connections. A red color indicates a short condition in the sensor, cable, or connections. Yellow means the excitation voltage is being monitored and is an indication of an open circuit.

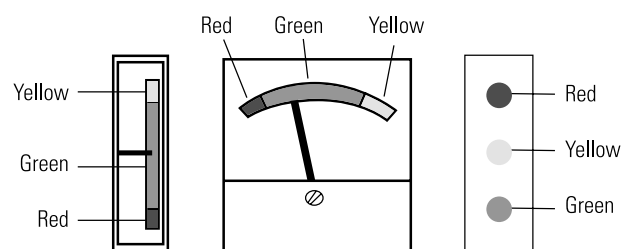

Figure 10. Typical Fault Indicators

## 5.1 APPARENT OUTPUT DRIFT (WHEN AC-COUPLED)

AC-coupled signal conditioners require sufficient time to charge their internal coupling capacitor. This capacitor must charge through the input resistance of the readout instrument and, if a DC readout is used, the output voltage will appear to drift slowly until charging is complete. A one-megohm readout device will require  $5 \times 1 \text{ meg} \times 10 \text{ } \mu\text{F}$  or 50 seconds to essentially complete charging. (Assumes stable operation after five discharge time constants:  $5 \times \text{Resistance} \times \text{Capacitance}$ . See Section 7.1)

## 6 HIGH FREQUENCY RESPONSE OF ICP® SENSORS

ICP® sensor systems ideally treat signals of interest proportionally. However, as the frequency of the measurand increases, the system eventually becomes nonlinear. This is due to the following factors:

- 1 Mechanical Considerations
- 2 Amplifier/Power Supply Limitations
- 3 Cable Characteristics

Each of these factors must be considered when attempting to make high frequency measurements.

### 6.1 Mechanical Considerations

The mechanical structure within the sensor most often imposes a high frequency limit on sensing systems. That is, the sensitivity begins to rise rapidly as the natural frequency of the sensor is approached.

$$= \sqrt{(k/m)} \quad \text{(Equation 6)}$$

where: = natural frequency

k = stiffness of sensing element

m = seismic mass

This equation helps to explain why larger or, more massive sensors, in general, have a lower resonant frequency.

Figure 11, below, represents a frequency response curve for a typical ICP® accelerometer.

It can be seen that the sensitivity rises as frequency increases. For most applications, it is generally acceptable to use this sensor over a range where sensitivity deviates by less than  $\pm 5\%$ . This upper frequency limit occurs at approximately 20% of the resonant frequency. Pressure and force sensors respond in a similar manner.

Mounting also plays a significant role in obtaining accurate high-frequency measurements. Be certain to consult installation procedures for proper mounting.

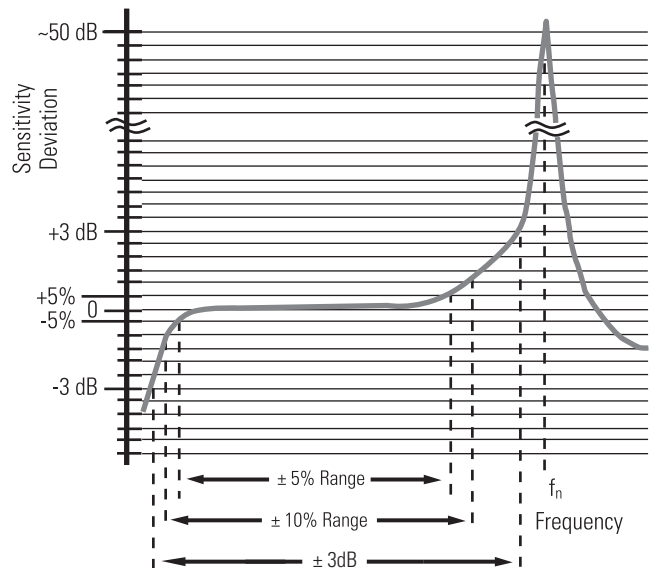

## 6.2 AMPLIFIER/POWER SUPPLY LIMITATIONS

When testing at extremely high frequencies (>100 kHz), the type of sensing system becomes important. In general, voltage amplified systems respond to frequencies on the order of 1 MHz, while most charge amplified systems may respond only to 100 kHz. This is typically due to limitations of the type of amplifier, as well as capacitive filtering effects. For such cases, consult the equipment specifications, or call PCB for assistance.

## 6.3 CABLE CONSIDERATIONS AND CONSTANT CURRENT LEVEL

Operation over long cables may affect frequency response and introduce noise and distortion when an insufficient current is available to drive cable capacitance.

Unlike charge-mode systems, where the system noise is a function of cable length, ICP® sensors provide a high-voltage, low-impedance output, well-suited for driving long cables through harsh environments. While there is virtually no increase in noise with ICP® sensors, the capacitive loading of the cable may distort or filter higher frequency signals, depending on the supply current and the output impedance of the sensor.

Generally, this signal distortion is not a problem with lower frequency testing up to 10 kHz. However, for higher frequency vibration, shock, blast or transient testing over cables longer than 100 ft (30 m), the possibility of signal distortion exists.

The maximum frequency that can be transmitted over a given cable length is a function of both cable capacitance and the ratio of the peak signal voltage to the current available from the signal conditioner, according to:

$$f_{\max} = 10^9 \frac{V}{2\pi C l_c} \quad (\text{Equation 7})$$

where,  $f_{\max}$  = maximum frequency (Hz)

$C$  = cable capacitance (picofarads)

$V$  = maximum peak output from sensor (volts)

$l_c$  = constant current from signal conditioner (mA)

$10^9$  = scaling factor to equate

units

Note that in this equation, 1 mA is subtracted from the total current supplied to sensor ( $l_c$ ). This is done to compensate for powering internal electronics. Some specialty sensor electronics may consume more or less current. Contact the manufacturer to determine the correct supply current.

When driving long cables, Equation 7 shows that, as the length of cable, peak voltage output or maximum frequency of interest increases, a greater constant current will be required to drive the signal.

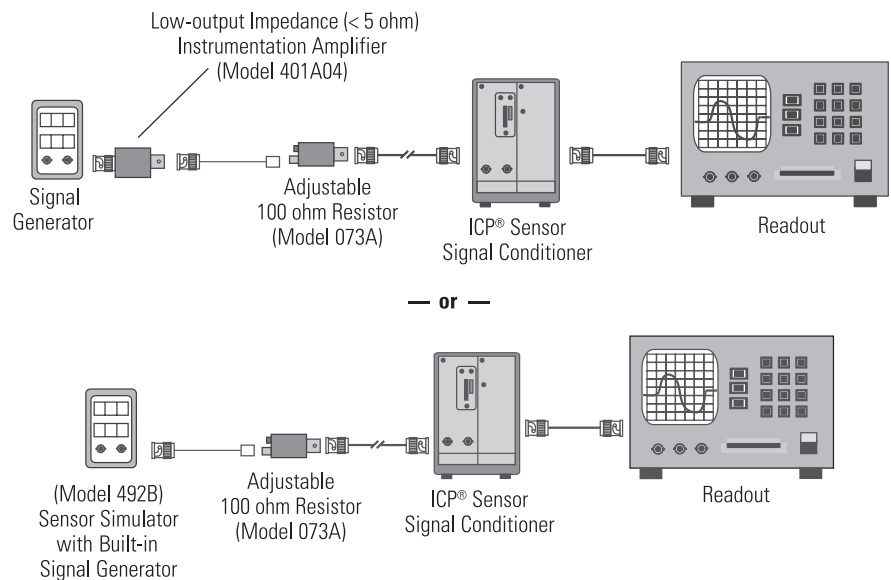

Figure 12. Testing Long Cables

The nomograph (Figure 13) provides a simple, graphical method for obtaining expected maximum frequency capability of an ICP® measurement system.

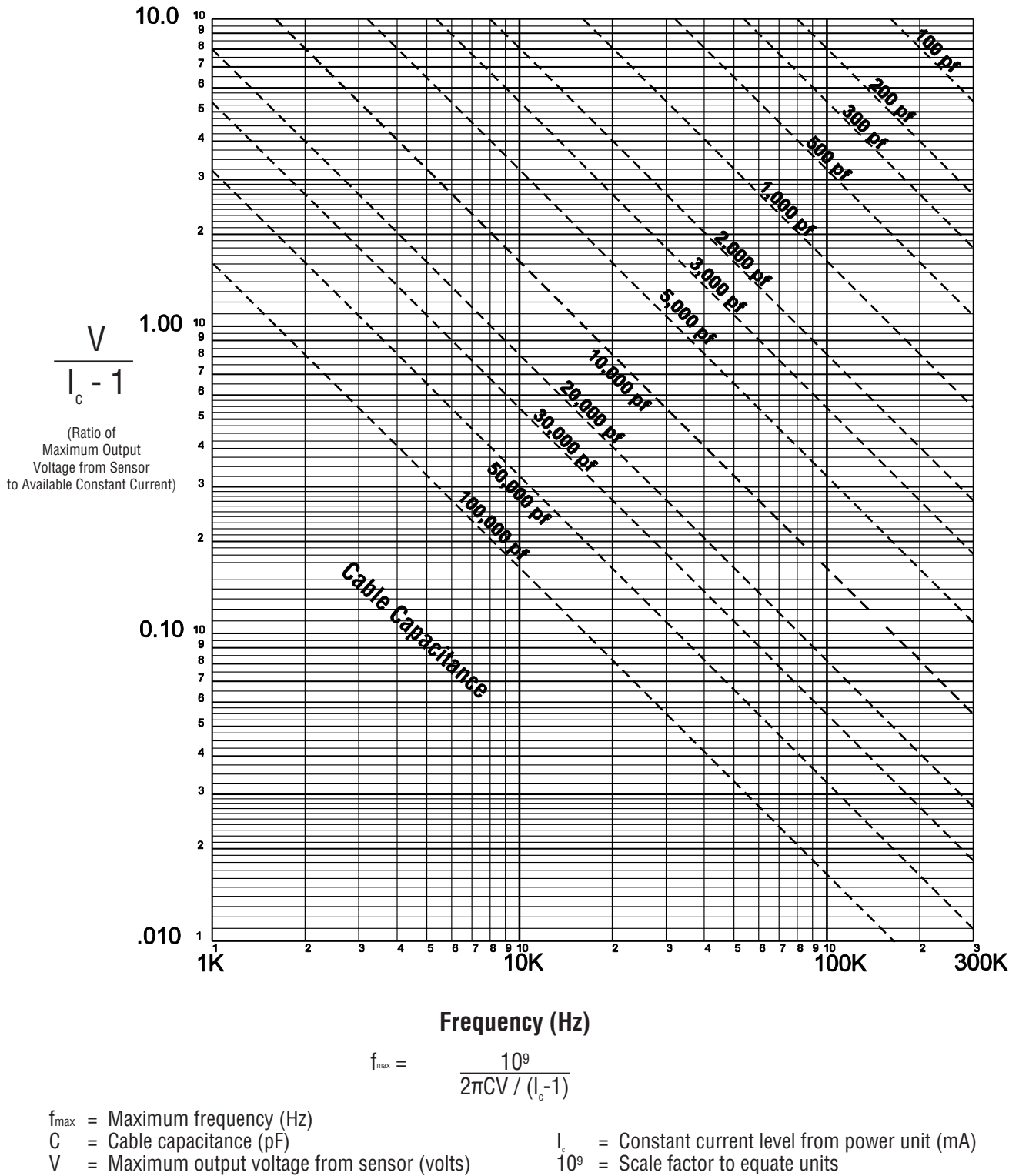

Figure 13. Cable Driving Nomograph

The maximum peak signal voltage amplitude, cable capacitance and supplied constant current must be known or presumed.

For example, when running a 100 ft (30.5 m) cable with a capacitance of 30 pF/ft, the total capacitance is 3000 pF. This value can be found along the diagonal cable capacitance lines. Assuming the sensor operates at a maximum output range of 5 volts and the constant current signal conditioner is set at 2 mA, the ratio on the vertical axis can be calculated to equal 5. The intersection of the total cable capacitance and this ratio result in a maximum frequency of approximately 10.2 kHz.

The nomograph does not indicate whether the frequency amplitude response at a point is flat, rising or falling. For precautionary reasons, it is good general practice to increase the constant current (if possible) to the sensor (within its maximum limit) so that the frequency determined from the nomograph is approximately 1.5 to 2 times greater than the maximum frequency of interest.

Note that higher current levels will deplete battery powered signal conditioners at a faster rate. Also, any current not used by the cable goes directly to power the internal electronics and will create heat. This may cause the sensor to exceed its maximum temperature specification. For this reason, do not supply excessive current over short cable runs or when testing at elevated temperatures.

## 6.4 EXPERIMENTAL TEST OF LONG CABLES

The first method illustrated in Figure 12 involves connecting the output from a standard signal generator into a unity gain, low-output impedance (<5 ohm) instrumentation amplifier in series with the ICP® sensor. The extremely low-output impedance is required to minimize the resistance change when the signal generator and amplifier are removed from the system. The alternate test method, also shown in Figure 12, incorporates a sensor simulator which contains a signal generator and sensor electronics conveniently packaged together.

In order to check the frequency/amplitude response with either of these systems, set the signal generator to supply the maximum amplitude of the expected measurement signal. Observe the ratio of the amplitude from the generator to that shown on the scope. If this ratio is 1:1, the system is adequate for your test. (If necessary, be certain to factor in any gain in the signal conditioner or scope.) If the output signal is rising (e.g., 1:1.3), add series resistance to attenuate the signal. Use of a variable 100 ohm resistor will help set the correct resistance more conveniently. Note that this is the only condition that requires the addition of resistance. If the signal is falling (e.g., 1:0.75), the constant current level must be increased or the cable capacitance reduced.

It may be necessary to physically install the cable during cable testing to reflect the actual conditions encountered during data acquisition. This will compensate for potential inductive cable effects that are partially a function of the geometry of the cable route.

## 7 LOW FREQUENCY RESPONSE OF ICP® SENSORS

With ICP® sensors, there are two factors which must be considered when acquiring low-frequency information. These are:

- 1 The discharge time constant characteristic of a sensor (a fixed value unique to each sensor).
- 2 The time constant of the coupling circuit used in the signal conditioner. (If DC coupling is used, only #1 needs to be considered).

It is important that both factors are readily understood by the user to avoid potential problems.

## 7.1 TRANSDUCER DISCHARGE TIME CONSTANT

The discharge time constant is the more important of the low frequency limits, because it is the one over which the user has no control.

Consider the ICP® sensors shown previously in Figure 6. While the sensing element will vary widely in physical configuration for the various types (and ranges) of pressure, force, and acceleration sensors, the basic theory of operation is similar for all. The sensing element, when acted upon by a step function measurand (pressure, force or acceleration) at  $t = t_0$ , produces a quantity of charge,  $\Delta q$ , linearly proportional to this mechanical input.

In quartz ICP® sensors, this charge accumulates in the total capacitance,  $C_{total}$ , which includes the capacitance of the sensing element, plus amplifier input capacitance, ranging capacitor and any additional stray capacitance. (Note: A ranging capacitor, which would be in parallel with the resistor, is used to reduce the voltage sensitivity and is not shown.) The result is a voltage according to the law of electrostatics:  $\Delta V = \Delta q / C_{total}$ . This voltage is then amplified by a MOSFET voltage amplifier to determine the final sensitivity of the sensor. From this equation, the smaller the capacitance, the larger the voltage sensitivity. While this is true, there is a practical limit where a lower capacitance will not significantly increase the signal-to-noise ratio.

In ceramic ICP® sensors, the charge from the crystal is typically used directly by an integrated charge amplifier. In this case, only the feedback capacitor (located between the input and output of the amplifier) determines the voltage output, and consequently the sensitivity of the sensor.

While the principle of operation is slightly different for quartz and ceramic sensors, the schematics (Figure 6) indicate that both types of sensors are essentially resistor-capacitor (RC) circuits.

After a step input, the charge immediately begins dissipating through resistor (R) and follows the basic RC discharge curve of equation

$$q = Qe^{-t/RC} \quad (\text{Equation 8})$$

Where:  $q$  = instantaneous charge (pC)

$Q$  = initial quantity of charge (pC)

$R$  = bias (or feedback) resistor value (ohms)

$C$  = total (or feedback) capacitance (pF)

$t$  = any time after  $t_0$  (sec)

$e$  = base of natural log (2.718)

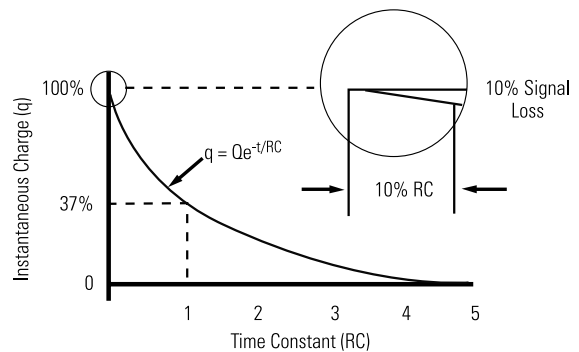

Figure 14. Characteristic Discharge Curve

This equation is graphically illustrated in Figure 14. Note that the output voltage signal from an ICP® sensor will not be zero-based as shown below, but rather based on an 8 to 10 VDC amplifier bias.

The product of R times C is the discharge time constant (DTC) of the sensor (in seconds) and is specified in the calibration information supplied with each ICP® sensor. Since the capacitance fixes the gain and is constant for a particular sensor, the resistor is used to set the time constant. Typical values for a discharge time constant range from less than one second to up to 2000 seconds.

## 7.1.1 EFFECT OF DTC ON LOW FREQUENCY RESPONSE

The discharge time constant of an ICP® sensor establishes the low-frequency response analogous to the action of a first order, high-pass, RC filter as shown in Figure 15A. Figure 15B is a Bode plot of the low-frequency response.

This filtering characteristic is useful for draining off low-frequency signals generated by thermal effects on the transduction mechanism. If allowed to pass, this could cause drifting, or in severe cases, saturate the amplifier.

The theoretical lower corner or frequency ( $f_0$ ), is determined by the following relationships, where DTC equals the sensor discharge time constant in seconds. See Table 1.

$$3\text{dB down: } f_0 = 0.16 / (\text{DTC}) \quad (\text{Equation 9})$$

$$10\% \text{ down: } f_0 = 0.34 / (\text{DTC}) \quad (\text{Equation 10})$$

$$5\% \text{ down: } f_0 = 0.5 / (\text{DTC}) \quad (\text{Equation 11})$$

### 7.1.2 Effect of DTC on Long Duration Time Waveforms

Often it is desirable to measure step functions or square waves of various measurands lasting several per cent of the sensor time constant, especially when statically calibrating pressure and force sensors.

The following is an important guide to this type of measurement: the amount of output signal lost and the elapsed time as a percent of the DTC, have a one-to-one correspondence up to approximately 10% of the DTC. Figure 16 shows the output voltage vs. time with a square wave input. (For accurate readings, DC couple the signal conditioner and readout instrument.)

At time  $t = t_0$  a step measurand (psi or lb.) is applied to the sensor and allowed to remain for 1% of the DTC at which time it is abruptly removed. The output voltage change  $\Delta V$ , corresponding to this input is immediately added to the sensor bias voltage and begins to discharge at  $t > t_0$ . When  $t = t_0 + (0.01 \text{ DTC})$ , the signal level has decreased by 1% of  $\Delta V$ . This relationship is linear to only approximately 10% of the DTC. (i.e., If the measurand is removed at  $t = 0.1 \text{ DTC}$ , the output signal will have discharged by approximately 10% of  $\Delta V$ .)

After 1 DTC, 63% of the signal will have discharged. After 5

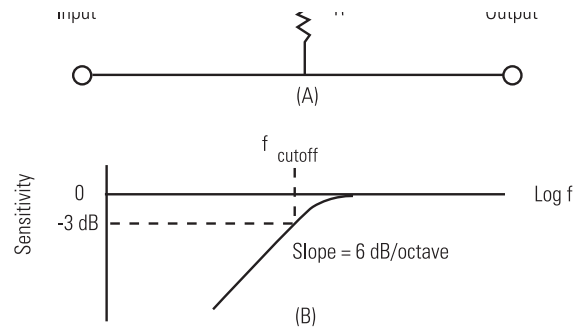

Figure 15. Transfer Characteristics of an ICP® Sensor

DTC (sec)	Frequency (Hz)		
	-5%	-10%	-3 dB
.1	5	3.4	1.6
.5	1	.68	.32
1	.5	.34	.16
5	.1	.07	.03
10	.05	.03	.016

Table 1. Low-frequency Response Table

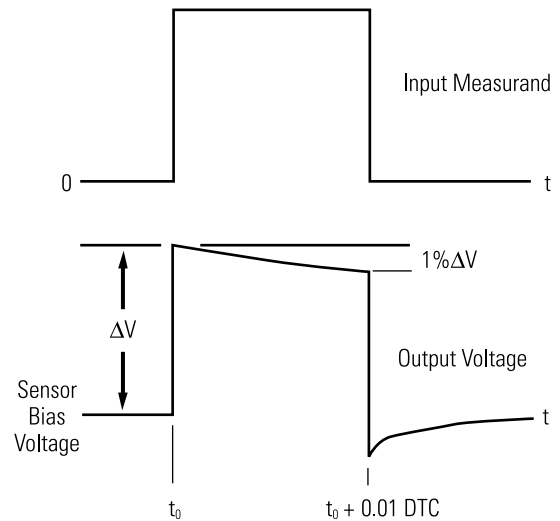

Figure 16. Step Function Response



DTCs, the output signal has essentially discharged and only the sensor bias voltage level remains.

Upon removal of the measurand, the output signal will dip below the sensor bias voltage by the same amount that it has discharged. Then, it will charge toward the sensor bias voltage level until reaching a steady state.

For a minimum 1% measurement accuracy, the discharge time constant should be at least 100 times the duration of a square wave event, 50 times the duration of a half ramp and 25 times the duration for a half sine pulse. Longer time constants will improve measurement accuracy.

## 7.2 EFFECT OF COUPLING ON LOW FREQUENCY RESPONSE

As previously mentioned, if the constant current signal conditioner (shown in Figure 5) is DC-coupled, the low-frequency response of the system is determined only by the sensor DTC. However, since many signal conditioners are AC-coupled, the total coupling DTC may be the limiting factor for low frequency measurements.

For example, Figure 7 illustrates typical AC-coupling through a 10  $\mu\text{F}$  coupling capacitor (built into many constant current signal conditioners.) Assuming a 1 megohm input impedance on the readout instrument (not shown), the coupling time constant simply equals  $R$  times  $C$ , or 10 seconds. (This also assumes a sensor output impedance of  $<100$  ohms.) As a general rule, keep the coupling time constant at least 10 times larger than the sensor time constant.

When acquiring low-frequency measurements, low-input impedance tape recorders and other instruments will reduce the coupling time constant significantly. For such cases, use a signal conditioner which incorporates DC-coupling or a buffered output.

## 8 METHODS OF DC COUPLING

To take full advantage of the sensor DTC, especially during static calibration, it is often essential to DC-couple the output signal. The simplest method is to use a signal conditioner which incorporates a DC-coupling switch. However, standard signal conditioners may also be adapted for DC-coupling by using a "T" connector, as in Figure 17.

The important thing to keep in mind is that the readout instrument must have a zero offset capability to remove the sensor bias voltage. If the readout is unable to remove all or a portion of the bias voltage, a current limited "bucking" battery or variable DC power supply, placed in-line with the signal, may be used to accomplish this task. It is imperative that any opposing voltage be current-limited, to avoid potential damage to the sensor's built-in circuitry.

For convenience, several constant current signal conditioners manufactured by PCB incorporate level shifting circuits to allow DC-coupling with zero volts output bias. Most of these units also feature an AC-coupling mode for drift-free dynamic operation.

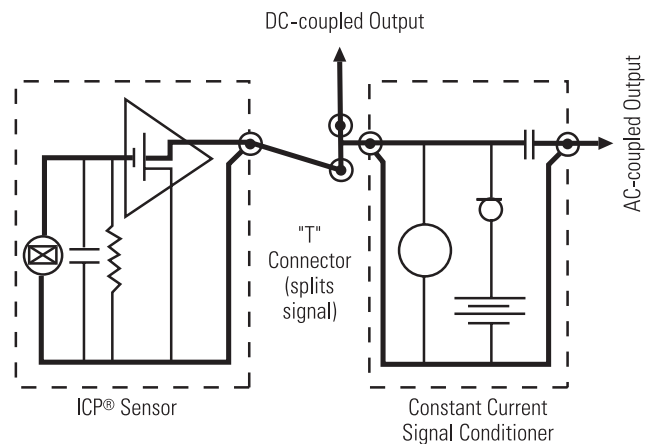

Figure 17. Adapted DC-coupled Sensing System

## 9 CAUTIONS

These precautionary measures should be followed to reduce risk of damage or failure in ICP® sensors:

- 1 Do not apply more than 20 mA constant current to ICP® sensors or in-line amplifiers.
- 2 Do not exceed 30 VDC supply voltage.
- 3 Do not apply voltage without constant current protection. Constant current is required for proper operation of ICP® sensors.
- 4 Do not subject standard ICP® sensors to temperatures above 250 °F (121 °C). Consult a PCB Applications Engineer to discuss testing requirements in higher temperature environments.
- 5 Most ICP® sensors have an all-welded hermetic housing. However, due to certain design parameters, certain models are epoxy sealed. In such cases, high humidity or moist environments may contaminate the internal electronics. In such cases, bake the sensors at 250 °F (121 °C) for one or two hours to evaporate any contaminants.
- 6 Many ICP® sensors are not shock-protected. For this reason, care must be taken to ensure the amplifier is not damaged due to high mechanical shocks. Handle such sensors with care, so as not to exceed the maximum shock limit indicated on the specification sheet.





**3425 Walden Avenue, Depew, NY 14043 USA**

pcb.com | info@pcb.com | 800 828 8840 | +1 716 684 0001

© 2021 PCB Piezotronics - all rights reserved. PCB Piezotronics is a wholly-owned subsidiary of Amphenol Corporation. Endevo is an assumed name of PCB Piezotronics of North Carolina, Inc., which is a wholly-owned subsidiary of PCB Piezotronics, Inc. Accumetrics, Inc. and The Modal Shop, Inc. are wholly-owned subsidiaries of PCB Piezotronics, Inc. IMI Sensors and Larson Davis are Divisions of PCB Piezotronics, Inc. Except for any third party marks for which attribution is provided herein, the company names and product names used in this document may be the registered trademarks or unregistered trademarks of PCB Piezotronics, Inc., PCB Piezotronics of North Carolina, Inc. (d/b/a Endevo), The Modal Shop, Inc. or Accumetrics, Inc. Detailed trademark ownership information is available at [www.pcb.com/trademarkownership](http://www.pcb.com/trademarkownership).

PCB-G001G-1021