

Piezoresistive accelerometer

Model 726CL

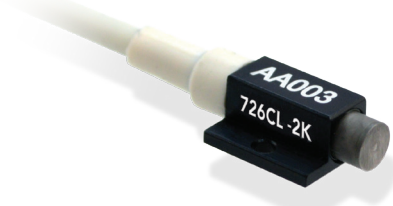
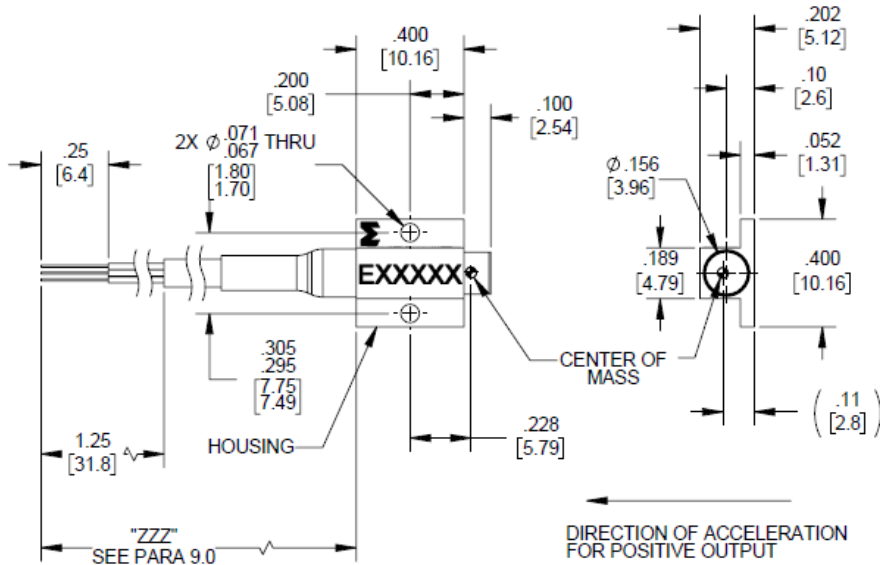

STANDARD TOLERANCE
INCHES [MILLIMETERS]
.XX = ± .02 [X = ± .5]
.XXX = ± .010 [XX = ± .25]

Key features

- High sensitivity 600mV FSO
- Multi-mode damping
- DC response and wide bandwidth
- Mechanical stops
- In-dummy application
- SAE J211/J2570 compliant

Description

Model 726CL is a very low mass accelerometer weighing only 1.4 grams. This accelerometer is designed for automotive safety testing applications that require, broad frequency response, and minimum zero shift following the event. Model 726CL utilizes a unique and advanced micro-machined piezoresistive sensor, which includes multi-mode damping for exceptional bandwidth with no significant resonance response in the usable range. This monolithic sensor incorporates the latest MEMS technology for ruggedness, stability and reliability over previous designs. With a frequency response extending down to dc (steady state acceleration), this accelerometer is ideal for measuring long duration transient shocks.

726CL has a full scale range of 2000 g and gas damping. It is available with less than 1% transverse sensitivity and less than ± 25 mV Zero Measurand Output as the "TZ" option. 726CL comes standard with calibration data for 2V, 5V and 10V excitation.

US patent 6,988,412 applies.

Piezoresistive accelerometer | Model 726CL

All specifications are referenced at +75°F (+24°C) and 10 Vdc, unless otherwise noted. Sensitivity and zero measureand offset are provided at 2V, 5V and 10V excitation. Calibration data, traceable to National Institute of Standards and Technology (NIST), is supplied.

Specifications		
Dynamic characteristics	Units	-2K
Range	g	± 2000
Sensitivity (at 100Hz and 10g)		
Minimum/Nominal/Maximum	mV/V/g	.010 / .030 / .060
Frequency response (Referenced to 100 Hz)		
+ 2.92%/-2.84% maximum	Hz	0 to 1200
+ 3.75%/-4.72% maximum	Hz	1200 to 1650
± 5% maximum	Hz	1650 to 5000
Non-linearity	%FSO	±1
Zero Measurand Output	mV	±50 maximum (±25 optional)
Transverse sensitivity	% max	3 (1 optional)
Resonance Frequency [1]	Hz	25,000
Thermal zero shift		
0° to 50°C	%FSO/°C	0.04
32° to 122°F	%FSO/°F	0.02
Thermal sensitivity shift		
0° to 50°C	%/°C	0.2
32° to 122°F	%/°F	0.1
Electrical characteristics		
Warm-up time	min	2
Excitation	Vdc	2.0, 5.0, 10.0
Input Resistance	ohms	3000 +/- 1500
Output Resistance	ohms	3000 +/- 1500
Insulation resistance	Mohms	100 min @ 50 Vdc
Residual Noise [2]	µV RMS	<10
Physical characteristics		
Case material		Hard anodized aluminum alloy, color black
Electrical connections		Integral 4 conductor, # 32 AWG ETFE insulated leads, shielded with white polyurethane jacket, 0.105 inch OD
Mounting torque		2.6 in-lbf (0.29 N.m) recommended/3.0 in-lbf (0.34 N.m) maximum
Weight		0.06 oz (1.8 gm); cable 0.12 oz/ft (11 gm/m), typical
Environmental		
Acceleration limits		
Shock (half-sine pulse duration)		10,000 g, 80 µsec or longer
Temperature		
Operating		- 40 to +100°C (-40 to +212°F)
Storage		Room temperature
Humidity		IP65
Calibration		
Each sensor includes an ISO 17025 calibration with the below information:		
Sensitivity (ref 10g, 100Hz) @ 2V, 5V and 10V		
ZMO @ 2V, 5V and 10V		
Frequency Response (20 to 5000Hz, ref 100Hz)		
Input and Output Resistance		

Piezoresistive accelerometer | Model 726CL

Accessories		
Options	Description	726CL
EHM35	Allen wrench	Included
EHW196	Size-0 flat washers (x2)	Included
EH828	0-80 x3/16 inch socket head cap screw (x2)	Included
7953A	Triaxial mounting block	Optional

Notes

- The primary resonance (25kHz) and the secondary resonance (36kHz) are both heavily damped. Using our proprietary multi-mode damping technique, these resonance peaks are completely suppressed or minimized to a significant degree, leaving the sensor virtually resonance free in practice. See the chart below for typical frequency response.
- Theoretical noise floor measured using a low-noise Op-amp. In practice, noise performance is dominated by the characteristics of the interfacing bridge amplifier.
- Maintain high levels of precision and accuracy using Endevco's factory calibration services. Call Endevco's inside sales force at 866-ENDEVCO for recommended intervals, pricing and turn-around time for these services as well as for quotations on our standard products.
- Model number definition:

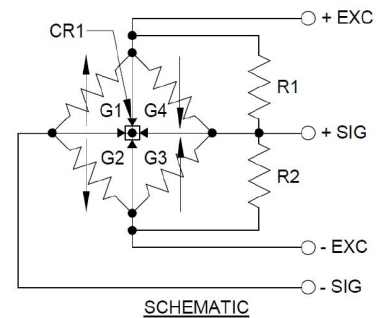
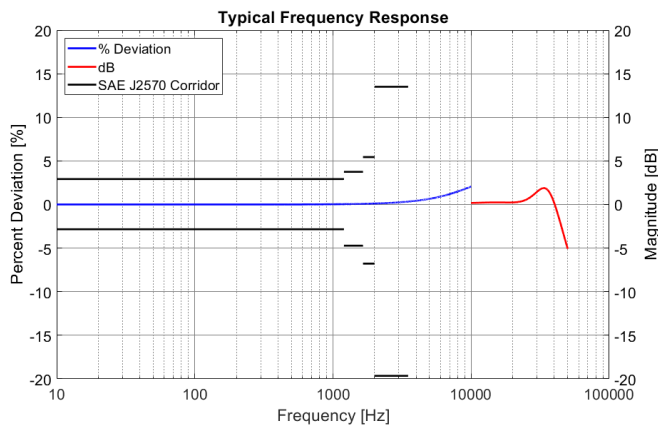
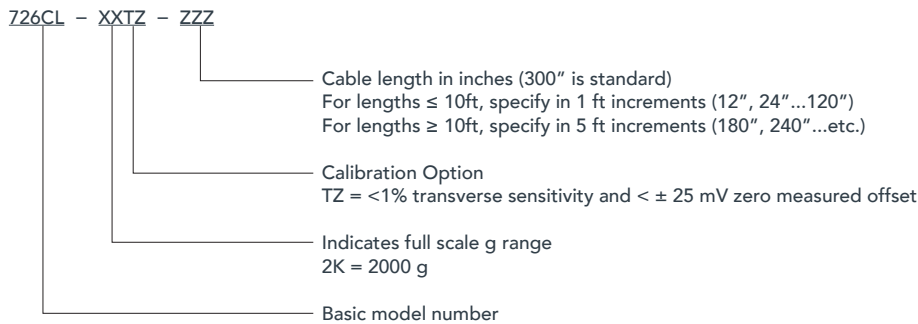

10869 NC Highway 903, Halifax, NC 27839 USA

endevco.com | sales@endevco.com | 866 363 3826

© 2022 PCB Piezotronics - all rights reserved. PCB Piezotronics is a wholly-owned subsidiary of Amphenol Corporation. Endevco is an assumed name of PCB Piezotronics of North Carolina, Inc., which is a wholly-owned subsidiary of PCB Piezotronics, Inc. Accumetrics, Inc. and The Modal Shop, Inc. are wholly-owned subsidiaries of PCB Piezotronics, Inc. IMI Sensors and Larson Davis are Divisions of PCB Piezotronics, Inc. Except for any third party marks for which attribution is provided herein, the company names and product names used in this document may be the registered trademarks or unregistered trademarks of PCB Piezotronics, Inc., PCB Piezotronics of North Carolina, Inc. (d/b/a Endevco), The Modal Shop, Inc. or Accumetrics, Inc. Detailed trademark ownership information is available at www.pcb.com/trademarkownership.