

12331

PCB Piezotronics Inc. claims proprietary rights in the information disclosed hereon. Neither it nor any reproduction thereof will be disclosed to others without written consent of PCB Piezotronics Inc.

APPLICATION		
NEXT ASS'Y	USED ON	VAR

REVISIONS				
REV	DESCRIPTION	ECN	DATE	APP'D
B	CHANGE REMOVAL TOOL	16343	3/26/03	<i>dmj/03</i>

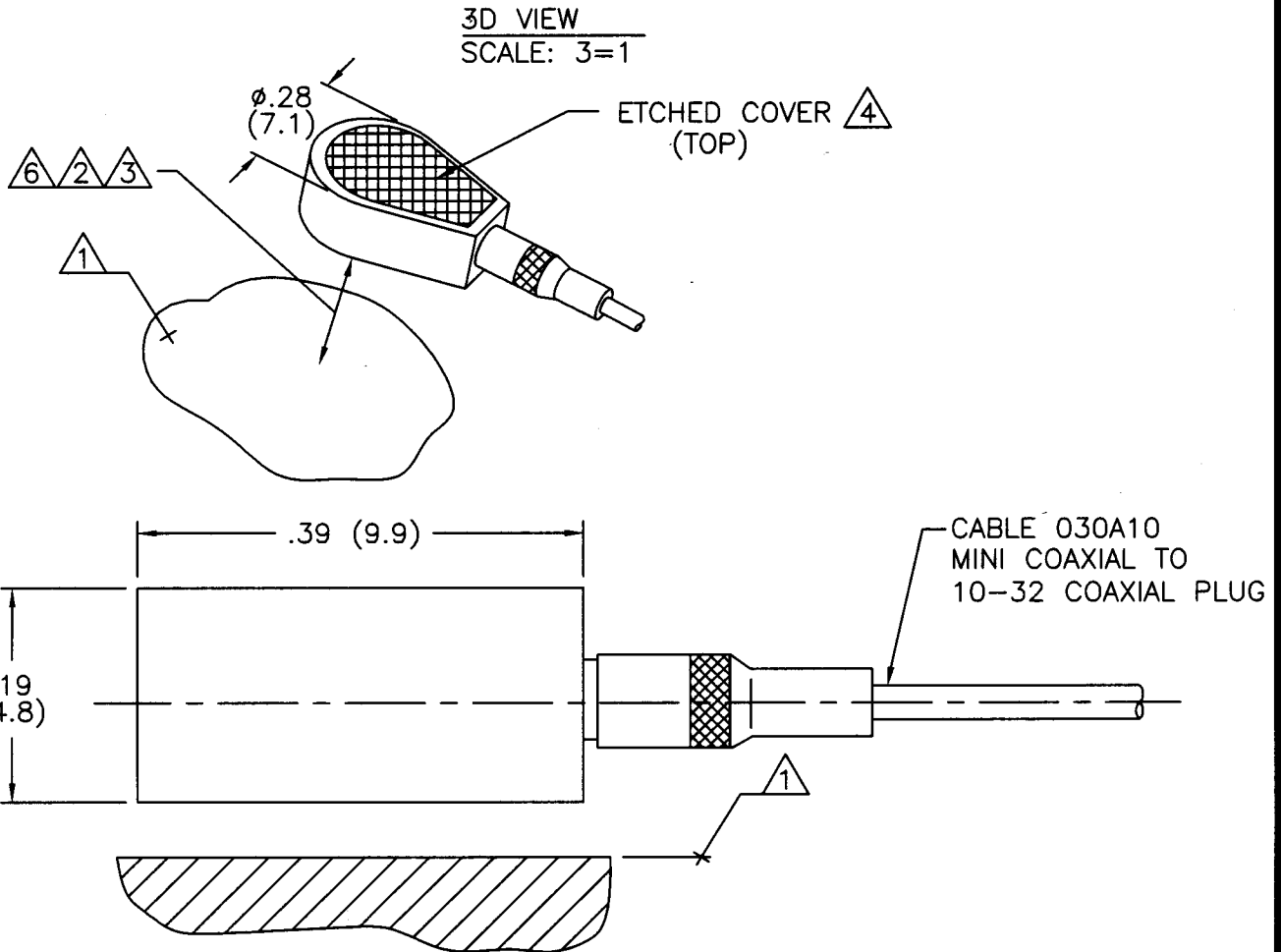

- ⚠️ BE CAREFUL TO NOT APPLY "QUICK BONDING GEL" TO CONNECTOR THREADS, IMPROPER CONNECTOR MATING WILL RESULT.
- 5.) SEE SHEET 2 OF 2 FOR CABLE STRAIN RELIEF AND REMOVAL INFORMATION.
- ⚠️ DO NOT MOUNT ON THIS SURFACE.
- ⚠️ FOR SEMI-PERMANENT MOUNTING USE MODEL 080A90 "QUICK BONDING GEL" OR EQUIVALENT.
- ⚠️ FOR TEMPORARY MOUNTING APPLICATIONS, USE PETRO WAX (MODEL 080A109). APPLY APPROXIMATELY 5 POUNDS(22 NEWTONS) OF FORCE TO TOP OF ACCELEROMETER CREATING A THIN BUT HOMOGENEOUS LAYER OF WAX.
- ⚠️ RECOMMENDED MOUNTING SURFACE SHOULD BE FLAT TO WITHIN .003(.08) TIR OVER  $\phi.375(\phi9.52)$  WITH A 32/ (.8/) FINISH FOR BEST RESULTS.

UNLESS SPECIFIED: TOLERANCES		DRAWN <i>Pm</i> 3/31/03	MFG <i>AL</i> 3/31/03	 3425 WALDEN AVE. DEPEW, NY 14043 (716) 684-0001 EMAIL: SALES@PCB.COM
DIMENSIONS IN INCHES	DIMENSIONS IN MILLIMETERS [IN BRACKETS]	CHK'D <i>dm</i> 3/31/03	ENGR <i>JMO</i> 4/1/03	
DECIMALS XX ±.01 XXX ±.005	DECIMALS X ±0.3 XX ±0.13	APP'D <i>WLB</i> 4/2/03	SALES <i>WJ</i> 4/1/03	
ANGLES ±2 DEGREES	ANGLES ±2 DEGREES	TITLE INSTALLATION DRAWING MODEL 352A24 ACCELEROMETER		
FILLETS AND RADII .003 - .005	FILLETS AND RADII [0.07 - 0.13]	CODE IDENT. NO. 52681	DWG. NO. 12331	SCALE: 6X
DD011 REV. C 01/21/03				SHEET 1 OF 2

12331

PCB Piezotronics Inc. claims proprietary rights in the information disclosed hereon. Neither it nor any reproduction thereof will be disclosed to others without written consent of PCB Piezotronics Inc.

APPLICATION		
NEXT ASS'Y	USED ON	VAR

REVISIONS				
REV	DESCRIPTION	ECN	DATE	APP'D
B	-SEE SHEET ONE-		3/26/03	DM3/pj

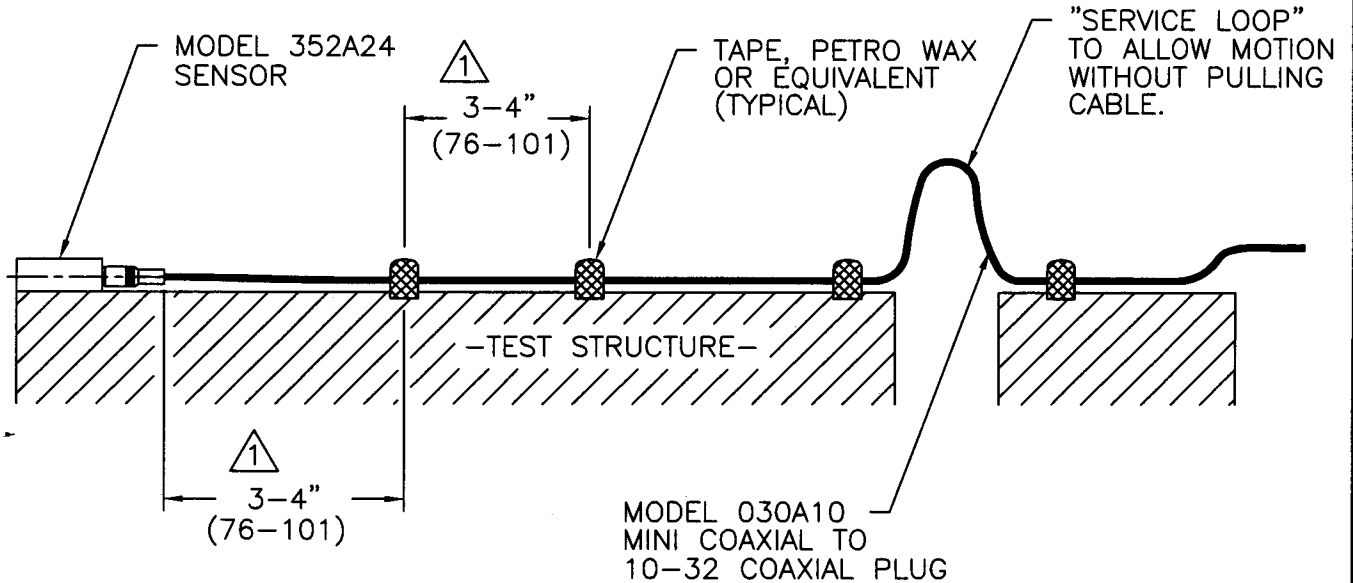

2.) TO AVOID UNNECESSARY DAMAGE TO THE SENSOR AND/OR CABLE, USE THE SUPPLIED REMOVAL TOOL (MODEL 039A28). A QUICK TWISTING MOTION WILL FREE THE SENSOR FROM THE TEST STRUCTURE.

FASTEN CABLE TO TEST STRUCTURE TYPICALLY WITHIN 3-4"(76-101) OF SENSOR. THEN FASTEN AGAIN WITHIN 3-4"(76-101) OF PREVIOUS ATTACHMENT. BETWEEN THE TEST STRUCTURE AND A FIXED STRUCTURE, ALLOW A SERVICE LOOP LARGE ENOUGH TO PREVENT PULLING OF THE CABLE WHEN SHAKING. MORE ATTACHMENT POINTS WILL PROVIDE LESS NOISE IN THE RESULTING DATA. LOOSE CABLES OR PARTS ELSEWHERE ON THE TEST STRUCTURE CAN ALSO GENERATE "NOISE" ON THE SIGNAL RECEIVED FROM THE MODEL 352A24.

UNLESS SPECIFIED: TOLERANCES		DRAWN				MFG		PCB PIEZOTRONICS™	
DIMENSIONS IN INCHES	DIMENSIONS IN MILLIMETERS [IN BRACKETS]	PM	3/21/03	AL	3/21/03	3425 WALDEN AVE. DEPEW, NY 14043	(716) 684-0001 EMAIL: SALES@PCB.COM CODE IDENT. NO. 52681 DWG. NO. 12331		
DECIMALS XX ±.01 XXX ±.005	DECIMALS X ±0.3 XX ±0.13	CHK'D DM	3/31/03	ENGR DM	4/1/03	DD011 REV. C 01/21/03			
ANGLES ±2 DEGREES	ANGLES ±2 DEGREES	APP'D 3/26/03	4/2/03	SALES WJ	4/1/03	TITLE INSTALLATION DRAWING MODEL 352A24 ACCELEROMETER SCALE: 1.25 X SHEET 2 OF 2			